

**Division of Orthopaedic & Accident Surgery
(Centre for Sports Medicine)**

University of Nottingham



**The Effects Of Functional Knee Bracing And
Taping On The Tibio-Femoral Joint In Athletes
With An ACL-Deficient Knee**

**By
Abbas Rahimi**

BSc MSc PT (Tehran University, Iran)

**Thesis Submitted To The University Of Nottingham for the Degree of
Doctor of Philosophy**

OCTOBER 2001

CONTENTS

CONTENTS	i
ABSTRACT.....	iv
ABBREVIATIONS	v
ACKNOWLEDGEMENTS.....	vi
DECLARATION	viii
LIST OF FIGURES	ix
LIST OF TABLES.....	xi
INTRODUCTION	1
Organisation of the Thesis	5
CHAPTER ONE – KNEE JOINT.....	6
1.1. Anatomy of the Knee Joint.....	6
1.1.1. Cruciate Ligaments.....	7
1.1.2. Function and Kinematics of the ACL.....	9
CHAPTER TWO - LITERATURE REVIEW.....	15
2.1. Biomechanics of the Anterior Cruciate Ligament (ACL).....	15
2.1.1. Demography of ACL Injury	16
2.1.2. Mechanism of Injury	17
2.1.3. The Fate of ACL-Deficient Knee Subjects	18
2.2. Biomechanical Studies in ACL-Injured Knees.....	19
2.2.1. “ <i>In vitro</i> (Cadaveric)” Studies	19
2.2.2. “ <i>In vivo</i> ” Studies.....	21
2.3. Bracing.....	35
2.4. Functional Knee Bracing	38
2.5. Bracing of the ACL-Deficient Knee “A Review of the Literature”	40
2.4.1. Static Brace Studies.....	40
2.5.2. Dynamic Brace Studies.....	42
2.6. Kinetic Analysis Following FKBs on the ACL-Deficient Knee	57
2.6.1 Quadriceps Avoidance Gait (QAG) Pattern in Detail	63
2.7. Taping.....	70
2.7.1. Use of Taping in the Later Stages of Injury Management	70
2.7.2. The Effects of Taping on the Tibio-Femoral Joint.....	71
2.8. Summary of the Literature Review.....	75
2.9. Translatory Kinematic Analysis of the ACL-Deficient Knee Joint - A Review of the Literature.....	79
2.9.1. Direct (Invasive) Methods.....	79
2.9.2. Indirect (Non - Invasive) Methods	80
2.10. Techniques to Reduce the Artefacts Caused by Surface Markers in Gait Analysis Studies.....	82
2.11. Recommendations for This Study.....	83
CHAPTER THREE - MATERIALS AND METHODS	85
3.1. General Methods and Specifications	85
3.2 Aims and Objectives of the Study	85
3.3. Hypotheses to Be Tested.....	85
3.3.1. Detailed Hypotheses.....	86

3.4. Recruitment of Subjects.....	86
3.4.1. ACL-Deficient Subjects	86
3.4.2. Control Group.....	87
3.5. Clinical Description of the Patients	87
3.5.1. Inclusion Criteria	87
3.5.2. Exclusion Criteria.....	87
3.6. Ethical Committee Approval	88
3.7. Test Modes.....	88
3.8. Outcome Measurements	88
3.8.1. Primary Outcome Measures	88
3.8.2. Secondary Outcome Measure.....	92
3.9. Gait Analysis Equipment.....	93
3.9.1. CODA mpx30 Motion Analysis Unit.....	94
3.9.2. Force Plate.....	96
3.9.3. Telemetered Dynamic Electromyography System.....	96
3.9.4. Treadmill	97
3.9.5. Functional Knee Brace	97
3.9.6. Taping.....	98
3.10. Other Measurements	99
3.11. Recording of Dynamic EMG.....	99
3.11.1. Electrode Placement.....	99
3.11.2. Skin Preparation	100
3.11.3. Muscles Tested	100
3.11.4. Position of the Electrodes.....	100
3.12. CODA's Marker Placement Set-up	100
3.13. Clustering Marker Placement Used in This Study.....	101
3.14. Virtual Markers.....	103
3.15. Procedure of Calculation of the Tibial Translation in This Study (Virtual Marker Method).....	104
3.16. Final Procedure for Recording.....	107
3.17. Data Processing.....	109
3.18. Statistical Analysis Used in This Study	110
3.19. Power Calculation.....	111
3.20. Summary of Methodology of the Research	113
CHAPTER FOUR - PILOT STUDY	121
4.1. Repeatability Test	121
4.1.1. Aims	122
4.1.2. Equipment	122
4.1.3. Data Analysis	122
4.1.4. Results	122
4.2. Pilot Study.....	126
4.2.1. Aims	126
4.2.2. Procedure.....	126
4.2.3. Test Modes	126
4.2.4. Equipment for Data Collection.....	127
4.3. Patients' Screening	127
4.3.1. Subjects Characteristics.....	127
4.4. Results.....	129
4.5. Amendments to the Main Study	130
4.6. Summary of the Pilot Study.....	131

CHAPTER FIVE - RESULTS.....	133
5.1. Characteristics of the Study Sample	133
5.1.1. Control Subjects	133
5.1.2. ACL-Deficient Subjects	133
5.2. Comparison of the Control Subjects and the Study Group.....	137
5.3. Kinematic Data Analysis	137
5.3.1. Temporospacial Gait Parameters	137
5.3.2. Range Of Motion (ROM)	143
5.3.3. Kinematics - Joint Positions	149
5.3.4. Knee Rotation.....	167
5.3.5. Anterior-Posterior (A-P) Tibial Translation.....	172
5.4. Kinetic Data Analysis	177
5.4.1. Moments and Power	177
5.5. Ground Reaction Force Data Analysis	191
5.5.1. Vertical (Impact) Force	192
5.5.2. Anterior-Posterior shear Force	192
5.6. EMG Data Analysis.....	196
5.6.1. Gastrocnemius Muscle and Different Movement Surfaces.....	205
5.7. Summary of the Results.....	211
CHAPTER SIX - DISCUSSION.....	219
6.1. GENERAL DISCUSSION	219
6.1.1. Why Was This Study Necessary?	220
6.1.2. Strengths and Limitations of This Study	222
6.1.3. Marker Placement Set-up	225
6.2. Results Interpretation.....	227
6.2.1. Kinematics.....	227
6.2.2. Kinetics.....	252
6.2.3. Force.....	261
6.2.4. Electromyography (EMG).....	263
6.3. Summary of Discussion.....	276
CHAPTER SEVEN – CONCLUSIONS	280
CHAPTER EIGHT.....
RECOMMENDATIONS FOR FUTURE RESEARCH.....	285
REFERENCES.....	287
Journals	287
Books	305
Conference Proceedings	307
Internet Communications.....	307
Theses	308
APPENDICES.....	309
Publications & Presentations	309
Ethical Committee Approval	310
Lysholm Score Form	314
Consent Form.....	316
Subject Information Sheet	317
Letter To GP	318
A Summary of the Project in Lay Language	319
Glossary.....	320

ABSTRACT

By Abbas Rahimi, Supervised by Professor W Angus Wallace, Division of Orthopaedic and Accident Surgery, School of Medical and Surgical Sciences, University of Nottingham.

The Effects of Functional Knee Bracing and Taping on the Tibiofemoral Joint in Athletes With an ACL-deficient Knee

Aims: The aims of this study were to determine the usefulness of a functional knee brace (FKB) or a spiral method of taping in modifying the impaired biomechanics of the ACL-deficient knees towards a safe and more normal pattern, and to assess any compensatory changes at the ankle and hip joints following knee bracing or taping. The study also aimed to compare the difference in gait patterns during simple level walking and treadmill activities for ACL-deficient subjects.

Methods: A prospective experimental study was carried out on 15 ACL-deficient and 15 carefully matched amateur athletes as controls. A comprehensive gait analysis study was designed using a high frequency CODA-*mpx30* gait analysis system, force platform and electromyography (EMG) system. The study was carried out during simple level walking, treadmill walking (3.6 Km/hr) and treadmill running (10 Km/hr) which we describe as low and high level physical activities. Treatments investigated included a functional knee brace (FKB) or a special spiral taping method that was applied to the deficient knees. The temporospatial parameters, total range of motion (ROM), joint position, kinetics and EMG parameters were recorded in the knee, ankle and hip joints in different trials with different supports and the results were compared with the baseline data of both the patients and the data derived from the control subjects.

Main Results: The FKB significantly reduced total ROM in the ACL-deficient subjects for all levels of walking trials ($P < 0.05$). The FKB significantly reduced peak knee flexion during swing while walking on level ground, but increased maximum knee flexion in swing during walking on the treadmill ($P < 0.05$). Taping significantly increased mean knee angle in stance in both walking modes ($P < 0.05$). Neither FKBs nor taping showed any angulatory kinematic effects on the knee joint during running on the treadmill. The FKBs could significantly reduce the antero-posterior (A-P) displacement of the tibia relative to the femur during level walking mostly in the swing phase. Wearing a brace did not reduce the knee extensor moments, but significantly reduced the hip flexor moments. Taping, however, had no significant effects on knee moment, but increased the generation and absorption of ankle power and decreased hip generation power. Bracing reduced the "support moment" and "support power" in the lower limb, but taping did not change them. No quadriceps avoidance gait pattern was found in this study and the patients showed an extensor knee moment throughout the stance phase. The gastrocnemius muscle was found to have a principal role in the ACL-deficient subjects and wearing a FKB could significantly activate the gastrocnemius muscles earlier in the ACL-deficient subjects, although no effects on peak activity of the muscle were demonstrated.

Conclusion: It can be concluded that the functional knee brace used in this study did not show any harmful effects in ACL-deficient knees. It was helpful particularly for low force activities such as level walking. The brace was as effective for walking on the treadmill as walking on level ground although some kinematic changes exist between these two different activities. Taping, however, is not recommended for ACL-deficient knees. Since the ACL-deficient subjects showed good knee control in most running trials, there would appear to be a need for more strenuous activities and these are strongly recommended.

ABBREVIATIONS

Abd/Add	Abduction/Adduction
Ant/Post	Anterior – Posterior
A-P	Anterior – Posterior
ACL	Anterior Cruciate Ligament
ACL-reconst.	Anterior Cruciate Ligament-reconstruction
ADL	Activities of Daily Living
ASIS	Anterior Superior Iliac Spine
CODA	Cartesian Optoelectronic Dynamic Antropometer
D.F.	Dorsi Flexion
Flex./Ext.	Flexion/Extension
FKB	Functional Knee Brace
Gastroc.	Gastrocnemius
GRF	Ground Reaction Force
HS	Heel Strike
Int/Ext Rot.	Internal / External Rotation
IC	Initial Contact
Int/ext Rot.	Internal / External Rotation
LED	Light-Emitting Diode
LR	Loading Response
Lt.	Left
Max.	Maximum
MCL	Medial Collateral Ligament
Med. Hamst.	Medial Hamstring
MMT	Manual Muscle Testing
N	Newton
P.F.	Plantar Flexion
PSIS	Posterior Superior Iliac Spine
QAG	Quadriceps Avoidance Gait
Rect. Fem.	Rectus Femoris
Rntrb.	Running on the treadmill with brace
Rntrn.	Running on the treadmill without brace
Rntrtp.	Running on the treadmill with tape
ROM	Range Of Motion
Rt.	Right
SD	Standard Deviation
St.	Stance
Sw.	Swing
Val./Var.	Valgus / Varus
Vast. Med.	Vastus Medialis
W	Watts (unit of power)
W.B.	Weight Bearing
N.W.B.	Non Weight Bearing
Wkgrnb.	Walking on level ground with brace
Wkgrn.	Walking on level ground without brace
Wkgrtp.	Walking on level ground with tape
Wktrb.	Walking on the treadmill with brace
Wktrn.	Walking on the treadmill without brace
Wktrtp.	Walking on the treadmill with tape

ACKNOWLEDGEMENTS

To be able to carry out this work, I owe a debt of sincere gratitude to many people. Firstly, my thanks must go at the Division of Orthopaedic & Accident Surgery and the Centre for Sports Medicine, The University of Nottingham. I acknowledge an enormous debt of gratitude to Professor W Angus Wallace for all his unfailing kindness and supervision in the course of the preparation of the thesis, and for his encouragement, endless guidance and support throughout the project. My sincere thanks are also due to Mr Forster, Consultant Orthopaedic Surgeon, who did his best as Clinical Director of the project and provided the ACL-deficient patients for the study. The author wishes to thank Miss Brigitte Scammell, Head of the Division, for her encouragement and financial support, which enabled the author to take part in the ESMAC Conference. I am also extremely grateful to Dr. Duvey, the statistician of the Trent Institute, Faculty of Medicine and Health Sciences for his great help and to Dr. Mark Batt for his guidance and feedback. The investigator wishes to thank all the staff of the Division, particularly Miss Joanne Hallam-Allsop, the Departmental Secretary, for all her patience and kindness; To Dr. Joanna Ford, researcher in the Department for her great help in correction and revision of the thesis; To the library staff of the University and the Faculty of Health and Medical Sciences for their help and courtesy and for the care and consideration they have shown. A great thank you to all of the ACL-deficient patients and volunteers who took part in the pilot and final study for their tolerance in having their gait measured on more than one occasion.

Secondly, in preparing this thesis I am indebted to many people in various places, mainly outside of Nottingham. Therefore, I would like to thank all Charnwood Dynamics (CODA, Loughborough) staff, especially Mr David Mitchelson and Mr Andrew Ward, who have supported me providing the latest version of the Coda software. My endless thanks and appreciation goes to Mr Phil Pickering, the Charnwood Dynamics' mathematical software engineer who has been with the author from the beginning to the end of the project, and the thesis could not have been completed without his help. My very sincere thanks are due to Mrs. Rose MacDonald (the former Director of Crystal Palace Club, London), for her great help for instruction to the author in the method of taping, and to Professor Roger

Woledge, Director and Professor of Experimental Physiology, and his assistant, Mr Matthew Thornton, Research Physiotherapist (Stanmore, London), for their help in making a suitable marker placement set-up for this study. I received the generous help and benefited from Dr Paul DeVita, Associate Professor in Exercise and Sports Science and Biomechanics (East Carolina University, USA), to whom I am very much in debt. Thank you for his hospitality at the time I was there to obtain his help in interpreting the data, and very great thanks for the continuous support and guidance I have received from him via e-mail for more than two years. He really acted as a joint supervisor for my work.

Thirdly, carrying out a thesis is not possible without financial support. The financial support for this work was provided by few sources; The Iranian Ministry of Health and Medical Education, and particularly Shahid Beheshti University, to which I am much obliged who kindly provided my tuition fees and the cost of living for me and my family. In England, a great tribute to mediUK on behalf of the DonJoy Company (USA), who generously provided the braces and taping consumables and always supported the project. My thanks and appreciation again to mediUK for kindly funding for my trips to Sweden and USA to take part in a conference and to enable me to visit Dr DeVita. Thanks also to the Department of Physiotherapy at the City Hospital, Nottingham, particularly Mr Andrew Kerr, Lecturer in physiotherapy and the manager of the Gait Laboratory, for his permission in using the CODA *mpx30* system.

Fourth, a compliment to my wife Fatemeh and my daughter Marzieh, and my family and friends in Iran, for their invaluable moral and practical support and patience in enduring my work on this thesis. I confess that it would not have been possible to finish this thesis without their continued encouragement. They tolerated what others would surely have found intolerable.

Fifth, I am beholden to a number of friends and reviewers for criticisms and suggestions, whose memories I will never forget. However, the views expressed here are the author's own. For all this work lacks, and for any remaining mistakes, he alone is responsible.

Finally, and most of all, my great thanks are to God for giving me health and continuing inspiration in carrying out this work.

DECLARATION

This thesis was carried out while I was in registered candidature. The studies described and presented in this thesis are the original work of the author, except where authors in the literature are cited.

LIST OF FIGURES

Figure 1-1 Anterior and Posterior Views of the Knee Joint.	12
Figure 1-2 Schematic Picture of Four-Bar Linkage in the Knee Joint.	14
Figure 2-1 Three Types of Knee Braces.	37
Figure 2-2. Quadriceps Avoidance Gait Phenomenon	63
Figure 2-3 Three Methods of Taping Used for Knee Injuries.	73
Figure 3-13 Schematic Positions of the Real and Virtual Markers	106
Figure 3-1 CODA-3 (The Old Version of CODA <i>mpx30</i>)	114
Figure 3.2 CODA <i>mpx30</i> Scanner Unit.....	114
Figure 3.3 Two Types Force Platforms Used in This Study.....	114
Figure 3-4 Electromyography Surface Electrodes & Transmitter Pack.	115
Figure 3-5 Treadmill Used in This Study.	115
Figure 3-6 Drive Boxes and LED Markers Used in This Study.	116
Figure 3-7 Legend DonJoy Functional Knee Brace (FKB) Used in This Study.	116
Figure 3-8 Running on the Treadmill with Taped ACL-Deficient Knee.....	117
Figure 3-9 Five Stages of Taping Used in This Study.....	118
Figure 3-10 Coda's Unilateral Marker Placement.	119
Figure 3-11 Schematic Figure of the Clustering Marker Placement Method Used in This Study	117
Figure 3-12 Non-Collinear Markers	104
Figure 4-1 Histograms of the "Repeatability Test" With Coda <i>mpx 30</i> Gait Analysis.	125
Figure 4-2 Consistency of the Kinematic and EMG Data during Running on the Treadmill.....	132
Figure 5-1 Boxplots Showing the Physical Profile of Study Participants.	135
Figure 5-2 "Temporospatial Gait Parameters".	140
Figure 5-3 Histograms Showing the Range of Motion (ROM) in the ACL-Deficient and Control Subjects.....	148
Figure 5-4 "Support ROM" in the ACL-Deficient and Control Subjects.....	149

Figure 5-5 Kinematics of the Ankle, Knee and Hip Joints during Walking on Level Ground.	164
Figure 5-6 Kinematics of the Ankle, Knee and Hip Joints during Walking on the Treadmill.....	165
Figure 5-7 Kinematics of the Ankle, Knee and Hip Joints during Running on the Treadmill.....	166
Figure 5-8 “Knee Rotation” in the ACL-Deficient and Control Subjects.	171
Figure 5-9 “ A-P Tibial Displacement” in the ACL-Deficient and Control Subjects....	176
Figure 5-10 “Moments” of the ACL-Deficient and Control Subjects.	182
Figure 5-11 “Power” of the ACL-Deficient and Control Subjects.	183
Figure 5-12 “Support Moment” and “Support Power” in the ACL-Deficients and the Control Subjects.....	184
Figure 5-13 Histograms Showing the Average Moment’s “Area Under the Curve” (Angular Impulse).....	188
Figure 5-14 Force Graphs During Walking on Level Ground.....	194
Figure 5-15 “Impact Impulse” during Walking on Level Ground.....	195
Figure 5-16 “Peak” EMG of Knee Muscles during Trials on Different Test Modes. ...	201
Figure 5-17 “RMS” EMG of Knee Muscles during Trials on Different Test Modes....	202
Figure 5-18 Typical “EMG Pattern” in a Non-Braced ACL-Deficient and a Control Subject in Different Test Modes.....	203
Figure 5-19 “Peak” and “Onset Activation Time” of the Gastrocnemius Muscle” During Trials on Different Test Modes.....	207
Figure 5-20 “Peak” and “Onset Activation Time” of the Gastrocnemius Muscle in Some ACL-Deficient and Control Subjects during Walking on Level Ground.	208
Figure 5-21 “Peak” and the “Onset Activation Time” of the Gastrocnemius Muscles in Some ACL-Deficient and Control Subjects during Walking on the Treadmill.....	209
Figure 5-22 “Peak” and “Onset Activation Time” of the Gastrocnemius Muscles in Some ACL-Deficient and Control Subjects during Running on the Treadmill.....	210

LIST OF TABLES

Table 2-1 Summary of the Studies in Kinematics of the ACL-Deficient Knee.	31
Table 2-2 Summary of EMG Studies in the ACL-Deficient Knee.	33
Table 2-3 Summary Studies of the Effects of FKBs in ACL-Deficient Knee.	51
Table 2-4 Summaries of The EMG Studies Following Bracing in ACL-Deficient Subjects.	56
Table 2-5 Summary of the Ground Reaction Force Studies in ACL-Deficient Knees....	67
Table 2-6 Summary of the Studies Regarding QAG and Proprioception in ACL- Deficient Knees.	68
Table 2-7 Summary of the Studies Regarding the Effects of Taping in the ACL-Deficient Knees.	74
Table 4-1 Results of the Repeatability Test.	123
Table 4-2 Results of Intra-Class Correlation Coefficient Tests on Six Braced Normal Subjects during Running on the Treadmill.	123
Table 4-3 Results of Subjects' Examination Tests (in Pilot Study).	128
Table 4-4 Characteristics of the Subjects Participating in the Pilot Study.	129
Table 5-1 Physical Profile of Study Participants.	133
Table 5-2 Characteristics of the ACL-Deficient and Control Group.	134
Table 5-3 Detailed Diagnosis and Physical Examination Tests in the ACL-Deficient Subjects.	136
Table 5-4 Mean (SD) of the Temporospacial Gait Parameters in the Normal and the ACL-Deficient Subjects during Walking on Level Ground.	138
Table 5-5 Results of <i>t</i> -tests in Temporospacial Gait Parameters between the Normal and the ACL-Deficient Subjects.	139
Table 5-6 Mean (SD) of Range of Motion (ROM) in the Ankle, Knee and Hip Joints during Walking on Level Ground.	144
Table 5-7 Results of <i>t</i> -tests in ROM of the Lower Extremity Joints while Walking on Level Ground.	144
Table 5-8 Mean (SD) of ROM in the Ankle, Knee and Hip Joints during Walking on the Treadmill.	145
Table 5-9 Results of <i>t</i> -tests of ROM in the Ankle, Knee and Hip Joints during Walking on the Treadmill.	145

Table 5-10 Mean (SD) of Total Range of Motions (ROM) in the Ankle, Knee and Hip Joints during Running on the Treadmill.	146
Table 5-11 Results of <i>t</i> -tests in ROM Measurement during Running on the Treadmill.	146
Table 5-12 Mean (SD) of Kinematic Parameters of the Knee Joint during Walking on Level Ground.	150
Table 5-13 Results of <i>t</i> -tests of the Kinematic Parameters of the Knee Joint during Walking on Level Ground.	150
Table 5-14 Mean (SD) of Knee Angle at Midstance during Walking on Level Ground.	151
Table 5-15 Results of <i>t</i> -tests of Knee Angle at Midstance during Walking on Level Ground.	151
Table 5-16 Mean (SD) of Kinematic Parameters of the Ankle Joint during Walking on Level Ground.	152
Table 5-17 Results of <i>t</i> -tests of Kinematic Parameters of the Ankle Joint during Walking on Level Ground.	153
Table 5-18 Mean (SD) of Kinematic Parameters of the Hip Joint during Walking on Level Ground.	154
Table 5-19 Results of <i>t</i> -tests of Kinematic Parameters of the Hip Joint during Walking on Level Ground.	154
Table 5-20 Mean (SD) of Kinematic Parameters of the Knee Joint during Walking on the Treadmill.	156
Table 5-21 Results of <i>t</i> -tests of Kinematic Parameters of the Knee Joint during Walking on the Treadmill.	156
Table 5-22 Mean (SD) of Kinematic Parameters of the Ankle Joint during Walking on the Treadmill.	157
Table 5-23 Results of <i>t</i> -tests of Kinematic Parameters of the Ankle Joint during Walking on the Treadmill.	157
Table 5-24 Mean (SD) of Kinematic Parameters of the Hip Joint during Walking on the Treadmill.	158
Table 5-25 Results of <i>t</i> -tests of the Kinematic Parameters of the Hip Joint during Walking on the Treadmill.	158
Table 5-26 Mean (SD) of Kinematic Parameters of the Knee Joint during Running on the Treadmill.	159

Table 5-27 Results of <i>t</i> -tests of Kinematic Parameters of the Knee Joint during Running on the Treadmill.....	160
Table 5-28 Mean (SD) of Kinematic Parameters of the Ankle Joint during Running on the Treadmill.....	161
Table 5-29 Results of <i>t</i> -tests of Kinematic Parameters of the Ankle Joint during Running on the Treadmill.....	161
Table 5-30 Mean (SD) of Kinematic Parameters of the Hip Joint during Running on the Treadmill.....	162
Table 5-31 Results of <i>t</i> -tests of Kinematic Parameters of the Hip Joint During Running on the Treadmill.....	163
Table 5-32 Mean (SD) of Knee Rotation during Different Test Modes.....	167
Table 5-33 Results of <i>t</i> -tests of Knee Rotation during Walking on Level Ground.	168
Table 5-34 Results of <i>t</i> -tests of Knee Rotation during Walking on the Treadmill.	169
Table 5-35 Results of <i>t</i> -tests of Knee During Running on the Treadmill.....	170
Table 5-36 Mean (SD) of Anterior-Posterior (A-P) Tibial Displacement during Different Test Modes (Virtual Marker Method).....	172
Table 5-37 Results of <i>t</i> -tests of A-P Tibial Displacement during Different Test Modes.	173
Table 5-38 Mean (SD) of Moments and Joint Power of the Knee Joint during Walking on Level Ground.	177
Table 5-39 Results of <i>t</i> -tests of Moments of the Ankle, Knee and Hip joints during Walking on Level Ground.	178
Table 5-40 Results of <i>t</i> -tests of Joint Power of the Ankle, Knee and Hip joints during Walking on Level Ground.	178
Table 5-41 Mean (SD) of Moments and Joint Power of the Ankle Joint during Walking on Level Ground.	179
Table 5-42 Mean (SD) of Moments and Joint Power of the Hip Joint during Walking on Level Ground.	180
Table 5-43 Results of “Support Moments” and “Support Power”.	184
Table 5-44 Mean (SD) of the Area under the Curve of Moments in the Ankle, Knee and Hip Joints during Walking on Level Ground.....	186
Table 5-45 Results of <i>t</i> -tests of Moments of the Ankle, Knee and Hip Joints during Walking on Level Ground.	186

Table 5-46 Mean (SD) of the Area under Curve of Power in the Ankle, Knee and Hip Joints during Walking on Level Ground.....	189
Table 5-47 Results of <i>t</i> -tests of Power of the Ankle, Knee and Hip Joints during Walking on Level Ground.	190
Table 5-48 Mean (SD) of Impact and Anterior-Posterior Shear Force during Walking on Level Ground.	191
Table 5-49 Results of <i>t</i> -tests Analysis of Force during Walking on Level Ground.	191
Table 5-50 “Peak” Values of EMG during Different Test Modes.....	196
Table 5-51 “Root Mean Square (RMS)” Values of EMG during Different Test Modes.	197
Table 5-52 Results of <i>t</i> -tests of EMG Parameters in Different Muscles During Walking on Level Ground.	198
Table 5-53 Results of <i>t</i> -tests of EMG Parameters in Different Muscles during Walking on the Treadmill.....	199
Table 5-54 Results of <i>t</i> -tests of EMG Parameters in Different Muscles during Running on the Treadmill.....	200
Table 5-55 Results of the “Peak” and “Onset Activation Time” of the Gastrocnemius Muscle during Different Test Modes.....	204
Table 5-56 Results of <i>t</i> -tests of the “Peak” and “Onset Activation Time” of the Gastrocnemius Muscle during Different Test Modes.....	204
Table 5-57 Results of <i>t</i> -tests of the Effects of Different Surfaces on the “Peak and “Onset Activation Time” of the Gastrocnemius Muscle.	205

INTRODUCTION

The anterior cruciate ligament (ACL) is considered to be one of the most important single ligament for stabilisation of the knee joint particularly in bipedal athletes. This ligament has a primary role in prevention of excessive anterior tibial displacement (Butler *et al*, 1991, Strobel & Hans-Werner, 1990) and on hyperextension of the knee joint (Zarins *et al* IN: McLean *et al*, 1998); and a secondary role in controlling varus/valgus and rotational stability at the knee (Fu *et al*, 1994). It is believed that ACL-deficiency leads directly to progressive degeneration within the knee joint (Biden & O'Connor, 1990; Cabaund IN: McLean, 1998).

ACL injury is now increasing in frequency in sports activities. Rupture of the ACL before or in the early part of an athlete's season presents a treatment dilemma: should the surgeon repair the ligament and end the athlete's season, or should physiotherapy be prescribed progressing to rehabilitative exercise and bracing to quickly return the athlete to competition? (Shelton *et al*, 1997). In the ACL-deficient knee, altered joint mechanics occurs and a rotary instability exposes the adjacent supporting ligaments and menisci to further degeneration (Myers *et al* IN: Osternig, *et al*, 1996; Johnson *et al* IN: Osternig, 1996; Brandt *et al* IN: Osternig *et al*, 1996).

Functional knee bracing is used mainly to stabilise an ACL-deficient knee either pre-operatively but sometimes post-operatively. Despite the extensive use of FKBs in ACL-deficient knees (Butler *et al*, 1991; Knutzen *et al*, 1991; Knutzen *et al*, 1987), objective proof of their benefits remains controversial and is still being questioned by the Orthopaedic & Sports Communities.

The literature emphasises that different braces may produce different changes in the biomechanics of the ACL-deficient knee (Cawley *et al*, 1991) and therefore, the type of braces in each study is important and must be noted.

Over the last two decades, there have been an increasing number of knees treated using taping resulting in thousands of dollars being spent on prophylactic taping each year (Hunter, 1985). Most injured athletes tape the knee either as a treatment or as a prophylactic tool and continue with their exercise. However, there are significantly few studies that demonstrate the positive effects of taping the knee joint (Barrett *et al*, 1991; Butler *et al* IN: Beynnon & Renstrom, 1991; Perlaud *et al*, 1995). In spite of taping

being costly and time consuming, it is very commonly used in joint injuries, particularly for small joints. To date, very little is known regarding the effectiveness of taping as a ligament support in healthy or injured knees, nor of its role in knee joint kinematics. Since only taping, and not bracing¹, is allowed in competitions, it is believed that if taping is effective in stabilising the ACL-deficient knee, the athletes with ACL-deficiency would be able to confidently participate in training or competitions with no concern about further deterioration.

A variety of methods are used to investigate the biomechanical changes, which occur following ACL injuries. These range from standard clinical evaluation to cadaveric models using a standard knee arthrometer, an electrogoniometer or a Roentgen stereophotogrammetric and optic/optoelectronic gait analysis device. These have all been used to determine the effectiveness of FKBs or taping on ACL-deficient knees.

The early literature indicates that the kinematic assessments were often carried out by simple devices such as manual goniometers. Electrogoniometry², accelerometry³, video analysis and optoelectronic scanning are different techniques for recording and analysing some dynamic activities. Use of videotaping and cameras and other advanced motion analysis apparatuses have simplified gait analysis and improved it so that it can be carried out in a more accurate manner.

Because of the small amounts of tibial translatory motion relative to the femur and the existence of a semi-circular locus of the instant centre in the knee joint, finding an accurate and non-invasive method to analyse tibial movement relative to the femur *in vivo* situations is very difficult and all of the above-mentioned methods have their own inherent limitations. For instance, the arthrometer and electrogoniometer are operator-based devices and their directions can easily be changed during dynamic tests on limbs. In addition to the potential dangers of exposure to X-rays in Roentgen techniques, because of the need for simultaneous orthogonal views, it seems practically impossible during an analysis of true dynamic motion (Cappozzo *et al*, 1996). In brief, errors in some previous studies have occurred mainly due to the lack of advanced instrumentation (Cawley *et al*, 1991). Cawley *et al* (1991) suggested that as a consequence of the above-

¹ Because of the possibility of hurting other players, bracing is NOT allowed in most competitions (Hackney and Wallace, 1999).

² A technique for electrical measurement of range of motion of the joints.

³ A technique for measurement of acceleration of motions.

mentioned problems, the results of some studies are not reliable and must be further investigated with optoelectronic techniques.

Some studies have used electromyographical profiles in ACL-deficient knees in normal walking and running. Those studies have shown that, in an ACL-deficient knee increased hamstring and decreased quadriceps activity may help them to compensate for their lax knees because of ACL damage. However, the effects of knee supports on muscular activities are not clear at best and further research is recommended in this area (DeVita 2000).

It can be concluded that despite the sufficient subjective results favouring bracing or taping, the objective proof is ambiguous and further studies are strongly recommended (Beynon *et al*, 1996; Nemmeth *et al*, 1997; DeVita *et al*, 1999; Ramsey *et al* 2001).

The majority of studies on the biomechanical effects of bracing on the ACL-deficient knee have been carried out during level ground activities. The injured knee subject frequently ask clinicians whether they can use treadmill as a safe indoor exercise tool either with or without a knee support. From the best knowledge of the investigators (from a detailed literature review), there is no multidisciplinary study which covers kinematic and EMG aspects of treadmill exercise at different speeds in ACL-deficient knee subjects and there is clearly a lack of research in this area.

A high frequency gait analysis system provides good opportunity to compare the impaired biomechanics of the ACL-deficient knee with the healthy knee using a treadmill at constant speed in the laboratory. This can also reveal the extent to which a FKB or taping is able to alter the ACL-deficient knee biomechanics towards a more normal pattern.

The purpose of this thesis was to help clarify the true effect of bracing in ACL-deficiency and to determine whether taping can be used as an alternative to bracing. Therefore, this study investigated the hypotheses that: 1) Using FKBs can improve the biomechanics of ACL-deficient knee towards a more normal pattern and consequently prevent the rotary instability and its further degeneration. 2) Taping can be used as a temporary support for ACL-deficient knees enabling athletes to participate actively in exercise.

This study specifically aimed to achieve the following:

- To gain a better understanding of the changes in the functions of the knee after ACL-deficiency using a combination of kinematic, kinetic and electromyographic (EMG) findings during walking on level ground and walking or running on the treadmill;
- To understand better the effects of functional knee bracing or taping on the biomechanics of the ACL-deficient knee and assess the biomechanical changes of the hip and ankle joints following the restriction of knee motion produced by bracing or taping.
- Finally, using virtual markers as a new feature in CODA *mpx30* gait analysis system, to explore a method of directly studying tibial displacements relative to the femur (linear kinematics) *in vivo*. By comparing of the results between the ACL-deficient subjects before and after knee bracing or taping and the control group, the extent by which the bracing or taping might restrict the excessive tibial movement will be monitored.

In brief, this thesis investigates the biomechanical assessment of the ACL-deficient knees before and after bracing or taping during low and high force activities on different surfaces (level ground and treadmill).

Organisation of the Thesis

The thesis is presented in eight chapters. The first chapter reviews the anatomical structure and function of the knee joint and the anterior cruciate ligament. A comprehensive review of the literature is presented in Chapter 2. Within this chapter the biomechanical situation of the knee following ACL-deficiency and the various issues of the effects of functional knee bracing or taping in terms of kinematics, kinetics, force and EMG findings is extensively reviewed and summaries of each section are provided as guideline tables at the end of each section.

Chapter 3 sets out the plan of the experimental study and describes the materials and methods of data collection. The clinical description of the subjects and the inclusion and exclusion criteria employed for the selected sample are also included. The experimental procedure adopted is also explained in this chapter. This Chapter also describes the use of the gait analysis equipment, which consists of the CODA *mpx30* motion analysis system, the force platform, the electromyograph (EMG), and the recording procedures. The methods of data analysis and the type of the brace and tape used in this study are also outlined. The statistical analysis and the power calculation of the sample size are also explained in the last part of the chapter.

In Chapter 4, the pilot study including the intra-day and inter-days reliability and repeatability test and the procedures of the pilot study will be presented.

Chapter 5 presents the complete results of the study, including the kinematic, kinetic and EMG findings of the normal and ACL-deficient subjects during different trials on level ground and on the treadmill with and without knee bracing or taping. The Tables of results, statistics and the related graphs will also be presented in this chapter. The most significant results of the study will be summarised at the end of the chapter.

In Chapter 6, the findings in Chapter 5 are discussed in two sections. The general discussions, confounding factors and the strengths and limitations of this study are discussed in the first section of the chapter. The complete interpretation of the results of the study will be discussed in the second part of this chapter and finally a summary of the highlighted points will be mentioned at the end of the chapter. The conclusions of the study are outlined in Chapter 7 and suggestions for future research are presented in Chapter 8. The reference lists follow Chapter 8 and finally, the appendices of the thesis, including forms and letters related to the project are at the end of the thesis.

CHAPTER ONE – KNEE JOINT

Introduction

In this Chapter, the anatomy and kinematics of the knee joint, with focus on the ACL, will be briefly reviewed.

1.1. Anatomy of the Knee Joint

The knee joint is complex and ranges from 0 to 140 degrees and represents the largest joint in the body. Normal function requires the smooth articulation of the tibiofemoral and the patellofemoral joints, the menisci and an intact tibiofibular syndesmosis. Its development has allowed upright bipedal walking in man, achieving both mobility and stability whilst withstanding large load bearing and propulsive forces. The femur angles medially from the pelvis and broadens at its distal end to form two epicondyles, inferior to which are the hyaline covered convex condyles. The medial condyle is larger and allows for the corrective valgus angulation of the tibia and also for the more stable position found in full extension, as the knee locks into position (Lockart *et al*, 1974; Moore & Agur, 1996). Normal knee flexion is from 0 to 135 degrees. From a position of nearly full extension at initial contact in walking on level ground, the rolling movements of femoral condyles over the tibia plateau start at about 15 degrees of flexion at loading response and continue until 20 degrees flexion is reached in the midstance phase. After 20 degrees of flexion, the ligaments become relax and permit both gliding and axial rotation. The patella glides over the end of the femoral trochlear groove as the knee bends. The knee recommences flexion during the middle of the swing phase and reaches its maximum at midswing.

The primary restraints to anterior and posterior translation of the joints are the cruciate ligaments. Passive restraints also include the menisci, which serve to deepen the articular surface and hence stabilise the joint and also to provide shock absorption and a smooth lubricated surface. The muscles surrounding the knee supply additional support and force. These consist primarily of the anterior extensor or quadriceps muscle groups. The more numerous posterior muscles include the hamstrings, biceps femoris, semimembranus, semitendinus and gastrocnemius as well as the pes anserine group, sartorius, gracillis and part of semitendinus.

1.1.1. Cruciate Ligaments

These strong intra-capsular, but extra-articular bands of fibrous tissue stretch upward between the tibia and the femur, crossing each other. The PCL is thicker than the ACL and is considered to be one of the strongest ligaments in the knee joint (Kennedy and Grainger, 1967; Bayley *et al*, 1988). The anterior and posterior cruciate ligaments (ACL, PCL) are named according to their tibial origins, and pass upward to attach to the intercondylar notch of the femur (Moore and Agur, 1980; Ellis, 1983) (Figure 1-1).

Anterior Cruciate Ligament (ACL)

Knowledge of the anatomy of the anterior cruciate ligament (ACL) is a prerequisite for understanding its function. The ACL is a multi-fascicular structure and is a major constraint on knee joint motion. It is a rope-like ligament with interwoven and overlapping fibres that control knee movement. The ACL may be injured when twisting movements (e.g. skiing) force the knee beyond its normal range of motion. This leads to the hearing or feeling of a "pop", experiencing pain, swelling or too much "play" in the knee which causes the knee to buckle (Fu and Ciccotti, 1994). A complete tear of the ACL is like the unravelling of rope fibres. Partial tears occur, but are less common.

This ligament is attached to a fossa on the tibia plateau in front of and lateral to the anterior tibia spine. It is 3.5 cm (± 1 cm) in length and a midportion width of 1.1 cm (± 0.1 cm) (Girgis *et al*, 1975; Fu and Ciccotti, 1994). From the tibia insertion, the ligament fibres ascend upwards, backwards and laterally to the femoral attachment on the posterior aspect of the medial surface of the lateral femoral condyle (Figure 1-1). The attachment of the ligament to the bone is mediated by a transitional zone of fibrocartilage and mineralised cartilage which prevents stress concentration at the attachment side allowing a gradual change in the stiffness (Arnoczky and Warren, 1988).

Blood Supply of the ACL:

The predominant blood supply to the ACL arises from the ligamentous branches of the middle genicular artery, but there is some blood supply also from the terminal branches of the medial and lateral inferior genicular arteries (Arnoczky and Warren, 1988; Moore & Agur, 1996; Lockart *et al*, 1974).

Nerve Supply of the ACL:

The ACL receives nerve fibres from the posterior articular branch of the posterior tibial nerve. Mechanoreceptors have been identified in the ACL, and these include Ruffini

endings, Gogi tendon organs, Pacinian corpuscles and some free nerve endings. These mechanoreceptors are involved in reflex arcs between the static ligament and the dynamic musculature (Draganich & Vahey IN: DeVita, 1992).

Structure of the ACL

Some studies show the ACL as a uniform ligament, however, others have differentiated between two type of fibres forming the ACL (Sakane *et al*, 1997). Those who believe that the ACL is a bi-part ligament divide the ACL into two fascicles. A small anteromedial bundle has fibres originating at the proximal aspect of the femoral attachment and they insert at the anteromedial aspect of the tibia attachment. The posterolateral bulk has fibres, which insert at the posterolateral aspect of the tibia attachment. In extension, the posterolateral fibres are considered to be under more tension than the anteromedial fibres (Daniel *et al*, 1985). In flexion, the anteromedial bundle is taut and the posterolateral fibres are lax. Sakane *et al* (1997) found that the magnitude of the in situ forces in the posterolateral bundle was larger than that of the anteromedial bundle at knee flexion angles between 0 and 45 degrees (maximum 75.2 ± 18.3 N at 15° of knee flexion under an anterior tibia load of 110 N). However, the magnitude of the in situ force in the anteromedial bundle remained relatively constant and did not change with flexion angle.

Using a mathematical model, O'Connor and Zavatsky (1990) demonstrated that the ACL consisted of multiple individual fibres each of which have separate isometric points and also that different fibres were loaded during knee motion. The anteromedial band attachments of the ACL, which are found to maintain the most consistent tension in flexion and extension, were shown to approximate the isometric point most closely. However, some researchers prefer the term *anatomic* placement rather than *isometric* placement as they believe it is unlikely that a specific spot is “isometric” for patients although a zone exists that presents an “isometric” region (Hafzy *et al* IN: Fu *et al*, 1994).

Furman *et al* (1976) manually tested 40 fresh cadaver knees and concluded that the anteromedial bundle of the ACL was the primary stabiliser of the flexed knee. The posterolateral bundle and the medial collateral ligament (MCL) were identified as the secondary and tertiary restraints limiting anterior drawer. Significant rotational instability was produced by complete resection of the ACL, but isolated lesions of either components did not cause instability that was likely to be detectable clinically.

It is well known that the force in the ACL is greater when the knee is fully extended when compared to flexion, which is a loose packed position. However, the force in the PCL, by applied internal tibial torque, is greater when the knee is in 90 degrees of flexion (Wascher *et al*, 1993). Markolf *et al* (1993) showed that a decreased force in the ACL accompanied an increased external tibial rotation between 0 and 20 degrees of flexion and an increased force in the PCL between 45 and 90 degrees of flexion. When the lateral collateral ligament and the posterolateral structures of the knee were damaged, both the ACL and PCL were recruited to resist applied varus moment and this placed them at an increased risk from potentially injurious forces.

Using a mathematical lower limb modelling, Toutoungi *et al* (2000) studied the intact ACL forces during typical rehabilitation exercises. They reported that during isokinetic/isometric extension, peak ACL forces occur at 35-40° and may reach 0.55 × body weight, but it did not load at 90° of knee flexion. They concluded that in rehabilitation of ACL injuries, squat is safer than isokinetic or isometric extension for quadriceps strengthening, though isokinetic or isometric flexion may safely be used for hamstring strengthening. Harner *et al* (1994) reported a significant difference in the incidence rate of ACL injury in the family history of the experimental group compared with the control group, indicating a possible congenital aspect of this injury.

1.1.2. Function and Kinematics of the ACL

Because of the controversy regarding ACL biomechanics, the diagnosis, treatment, and rehabilitation of an ACL disruption remains an enigma (Kirkendall & Garrett, 2000). The viscoelastic properties and biomechanical function of the ACL have received extensive scrutiny in the literature. Previous research has been restricted to subjective *in vivo* work and extensive *in vitro* investigations (Attfield *et al*, 1998).

Functionally, as a primary function the ACL resists anterior translation of the tibia relative to the femur in flexion of the knee joint, and resists excessive rotation of the tibia (mainly internal rotation) with respect to the femur (Zarins *et al* IN: McLean, *et al*, 1998). The ACL also prevents medial translation of the tibia in the extended knee and acts as a secondary restraint to both valgus and varus stresses in all degrees of flexion. Butler *et al* (1980) studied 14 frozen cadaver knees to investigate the concept of primary and secondary stabilisers. By associating a servo-controlled, electrohydraulic testing system with a precisely controlled antero-posterior (A-P) displacement, they measured the effect of serial ligament sectioning on the restraining force. They found that ACL is

responsible for 86% of the total force resisting anterior drawer. The iliotibial tract, mid medial capsule, mid lateral capsule, medial collateral ligament and lateral collateral ligament were identified as the secondary stabilisers and were listed in order of perceived importance.

Serial sectioning of the ACL and MCL on A-P force/displacement and tibial torque/rotation curves for seven frozen cadaver knees was also studied in Shoemaker and Markolf's study (1985). They confirmed the ACL as the primary structure controlling anterior drawer in the unloaded knee. The application of an axial load of 925 N significantly reduced laxity and this was attributed to a high degree of femoro-tibial congruency and the effect of the menisci blocking antero-posterior translation in extension. The ACL was also shown to have an effect in controlling torsional laxity but the MCL was most significant in this respect.

Generally, ACL injury occurs while the knee is flexed and the foot planted and sudden forceful twisting motion is performed. Typically, the tibia is externally rotated with respect to the femur causing the ACL to tighten by impinging on the lateral femoral condyle (Berns *et al*, 1992). The function of the cruciate ligaments is different in the stance and swing phases.

In normal knee function, the ACL and PCL in stance are instrumental in controlling the backward and forward displacement of the tibia on the femur. However, in the swing phase they prevent excessive external and internal rotation of the tibia under the femoral condyle (Kapandji, 1987; Laskin, 1995).

The ACL-deficient knees did not preserve the normal tibiofemoral relationship present in ACL-intact knees (Fu *et al*, 1994). Force transmission in specific regions of the ACL was found to vary with position of the knee. A mechanism of the crossed four bar linkage (Figure 1-2) is supposed to represent the basic principle of knee joint motion (Kapandji, 1987; Muller, 1988; Fu *et al*, 1994). Two links represent the cruciates and two links connect their attachments to the tibia and femur. The two hinge points in this system lie on a line at 40 degrees to the long axis of the femur, which corresponds to the angular relationship between the femoral axis and the roof of the inter-condylar notch.

The relative lengths of the anterior and the posterior cruciate ligaments, in this system, correspond to the length of the two arms. Constraints on the ideal position of the ACL on the tibia and femur exist in this model. The system describes the obligatory motion of the

surfaces, adhering to the rolling-gliding principle that predicts the posterior shift of the contact point as flexion occurs. To allow normal flexion and extension of the knee, each “bar” of the linkage system must be in proper relationship. This has led to the concept of limited optimal zone for the placement of grafts in ACL-reconstructive surgery.

Figure 1-1 Anterior and Posterior Views of the Knee Joint.

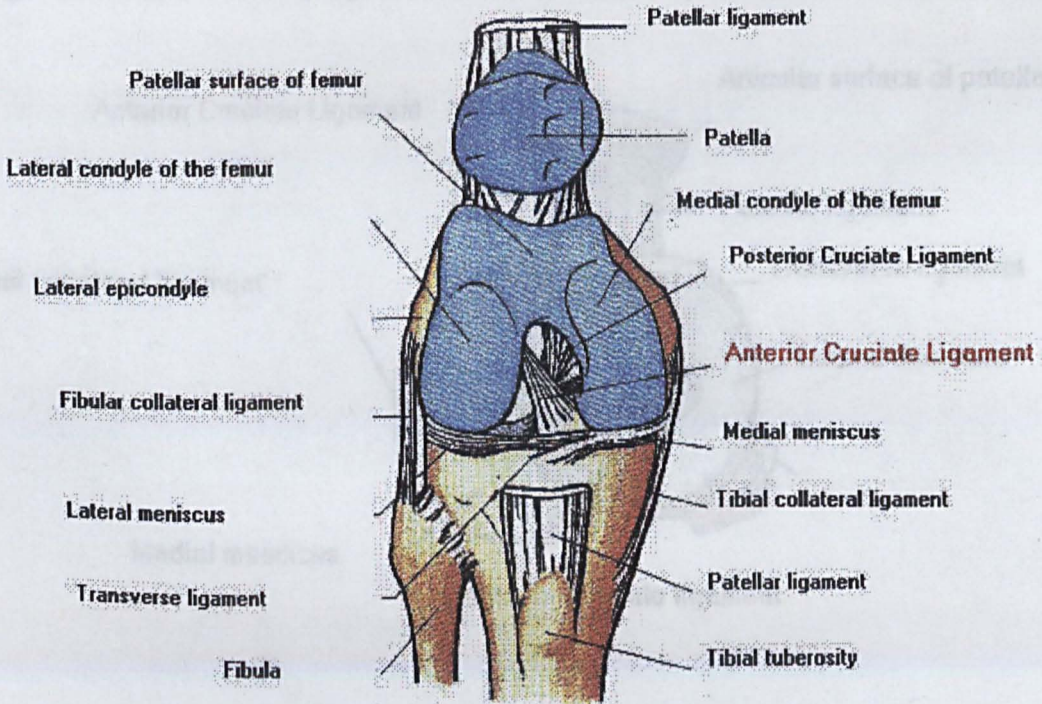

Anterior view of knee joint. (From Moore and Agure, Williams and Wilkins 1996).

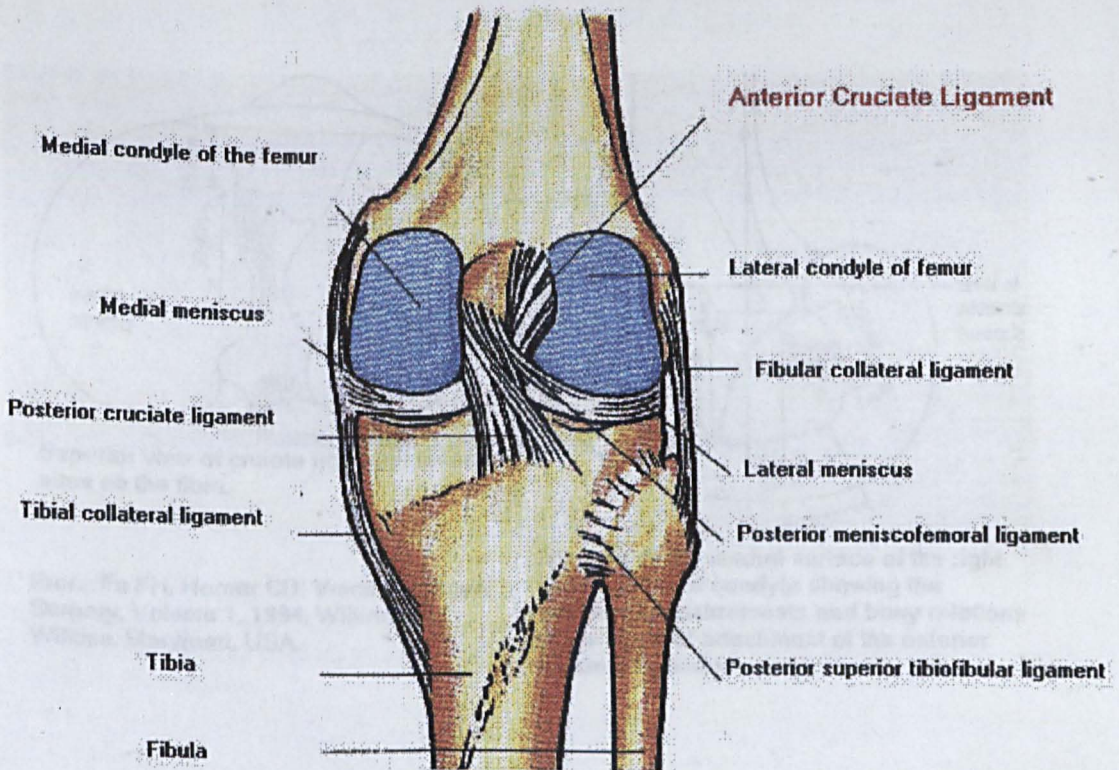

Posterior view of knee joint (From Moore and Agure, Williams and Wilkins 1996).

Figure 1-1 Knee Joint - (Superior and Lateral Views), cont.

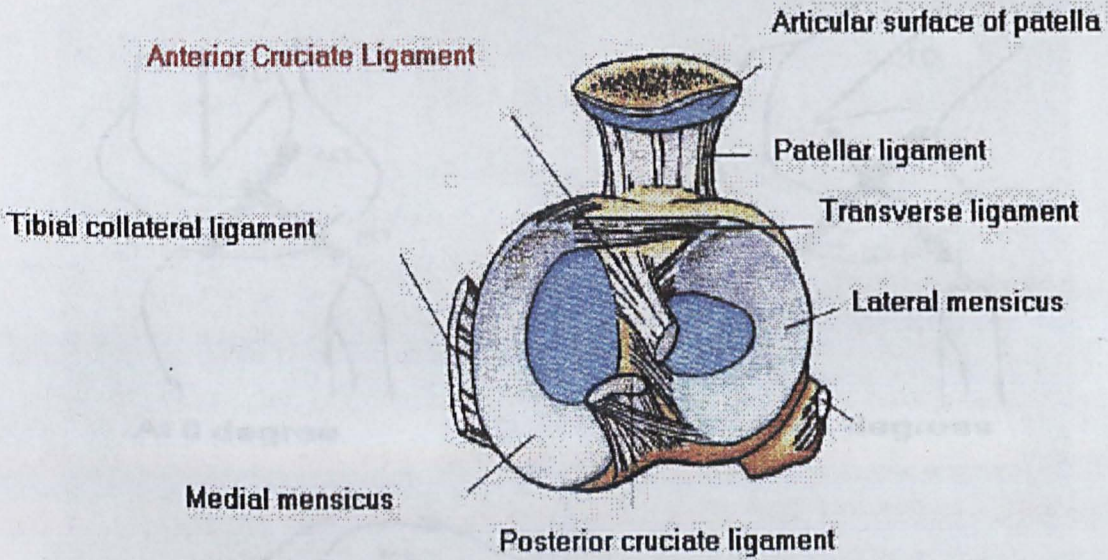

Superior view of knee joint
(From Moore and Agure. Williams and Wilkins 1996).

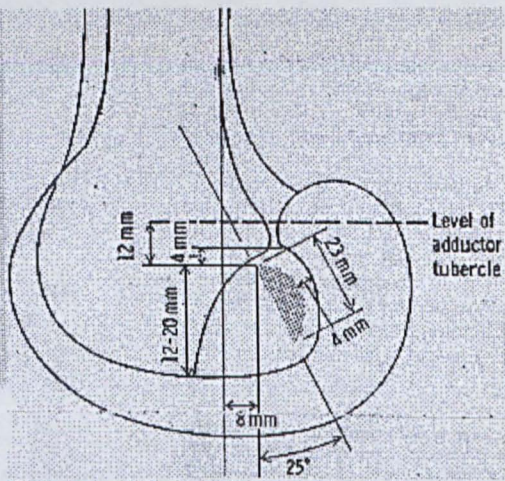
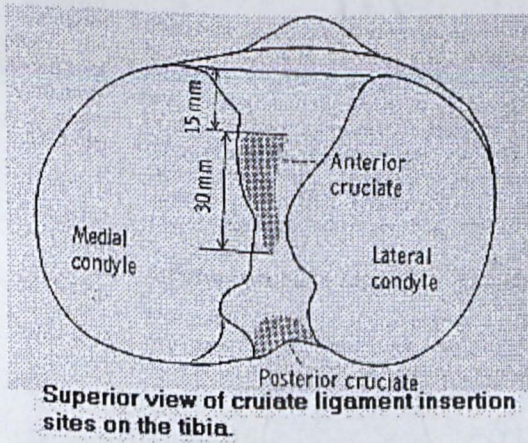

Drawing of the medial surface of the right lateral femoral condyle showing the average measurements and bony relations of the femoral attachment of the anterior cruciate ligament.

From: Fu FH, Harner CD, Vince KG. Knee Surgery, Volume 1, 1994, Williams & Wilkins, Maryland, USA.

Figure 1-2 Schematic Picture of Four-Bar Linkage in the Knee Joint.

[From: Fu H., Harner CD, Vince KG. et al. Knee Surgery, Vol.1, 1994, Williams & Wilkins, Maryland, USA

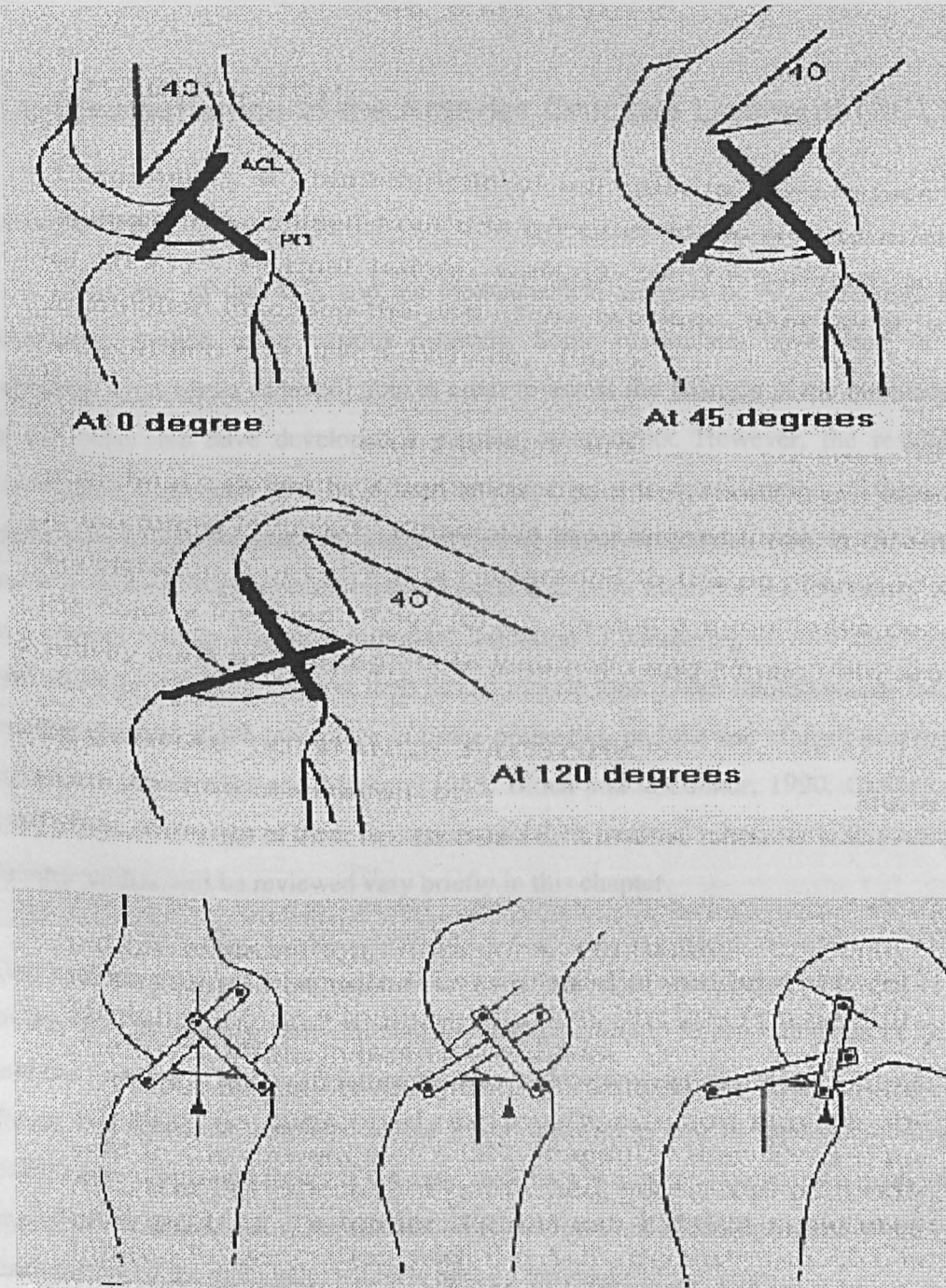

Schematic Picture of Four-Bar Linkage:

The cruciate ligaments lengths are not changed in spite of posterior migration of the tibiofemoral contact points during knee flexion in different angles.

CHAPTER TWO - LITERATURE REVIEW

2.1. Biomechanics of the Anterior Cruciate Ligament (ACL)

Introduction

The role of the ACL and the biomechanical analysis of ACL-deficient knees have been studied using various methods. Some researchers have used *in vitro* experiments on whole cadaver joints in order to assess the changes in the biomechanics of the knee, and have developed a number of concepts. However, the results and conclusions from such tests have been analysed prior to consideration of their direct application to clinical practice. There are some major limitations with *in vitro* studies and it is difficult to extrapolate biomechanical data from cadavers in a laboratory setting to a clinical setting. The most important limitation of comparing *in vitro* data to the *in vivo* situation is that the cadaver limb has no muscle tone. Other limitations are the post-mortem changes which take place in tissue properties, and the use of aged post-mortem specimens (Shoemaker and Markolf, 1985; Biden and O'Connor, 1990; Cawley *et al*, 1991). In consideration of these limitations and their minimal relevance to this study, the *in vitro* studies will be reviewed very briefly in this chapter.

Gait analysis provides information about knee motion *in vivo* during activities of daily living, such as walking, stair climbing, etc. Data relating to forces acting across the joint and the function of the musculature can also be obtained simultaneously. Thus resultant forces and moments generated at the lower limb joints can be calculated. However, calculation of ligament forces is not easy, and there is a need to construct a mathematical model of the knee to allow the calculation of the forces in all the ligaments of the knee at each instant of the gait cycle, which is beyond the scope of this study.

This Chapter covers various sections. Firstly the demography, fate, and the mechanism of ACL injury will be briefly reviewed. Secondary, the studies of ACL-injured knees, including *in vitro* and *in vivo* studies, will be reviewed to determine the biomechanical differences between ACL-deficient and healthy knees. The kinematic and EMG changes of ACL injury will be reviewed in the section detailing *in vivo* studies. Bracing and its use in the ACL-deficient knee form the next section of the Chapter. The static and

dynamic brace studies in ACL-deficient knees, brace and muscle activity, brace and kinetic, and brace and forceplate, will be extensively reviewed in this section. As a summary, a Table including all the studies in that specific area will be presented at the end of each field of study. Gait adaptation in ACL-deficient knees, and the so called “quadriceps avoidance gait” pattern, will be outlined in the next part of this Chapter. Taping of the tibiofemoral joint will be reviewed in the next section, followed by a summary of the reviews. Due to the importance of the translatory kinematics in this study, the current methods of translatory kinematic analysis of the knee joint, and the recommendations for this study can be found as a separate section at the end of this Chapter.

2.1.1. Demography of ACL Injury

The ACL is the most commonly injured knee ligament (Fetto and Marshal, 1980), and its injury occurs in a young and active population (Hawkins *et al* IN Daniel, 1994; Noyes *et al* IN: Jonsson, 1989; Rackemann *et al*, 1991; Satku *et al*, 1986). Sporting activities are responsible in the majority of cases (Monsell *et al*, 1992). Anterior cruciate ligament (ACL) injury is one of the most common and potentially most disabling sporting injuries, carrying with it significant morbidity in both the short-term and long-term. It is believed to lead directly to progressive degeneration within the knee joint (Biden and O'Connor, 1990; Cabaund IN: McLean, 1998). It has been reported that one in 3,000 individuals will suffer some form of ACL disruption, with 70% of acute ACL injuries occurring during vigorous sporting activity. Gibb's (IN: McLean *et al*, 1998) reported that in a three-year prospective study of a professional rugby league team, the knee was the most common site of injury (24%), with approximately 25% of these injuries involving the ACL. Philips (1998) reported the same results in four consecutive seasons in rugby league. There are estimated to be over 100,000 ACL ski injuries in the U.S.A per year (Feagin and Lambert, 1994).

It is claimed that the incidence of ACL injury is different in men and women (Kimberly and Dick, 1998), and that women over-troubled with this injury two to eight times more than men participating in the same sports (Huston *et al*, 2000). Viola *et al* (1999) studied an extensive group of male and female professional alpine skiers to find any relationship between gender and the incidence of ACL injury. A seven-year retrospective study was carried out and a particular screening method was used in this study. Screening involved a ski history questionnaire, a knee injury history questionnaire and a knee physical examination. Any patient with an equivocal Lachman or pivot shift test was evaluated by

KT-1000 arthrometry and excluded from the study if the manual maximal side-to-side difference was 3 mm or more so that the study was limited to subjects with intact anterior cruciate ligaments. They found that the incidence of anterior cruciate ligament injuries between male and female professional alpine skiers was similar, and concluded that gender is not an important factor in determining involvement in ACL-injury.

The National Collegiate Athletic Association NCAA⁴ (Kimberly and Randall, 1998) claimed that a reverse relationship exists between the skill level of the athletes and the risk of ACL injury. To evaluate if a decreased skill level is related to an increased rate of ACL injury, data from volunteers participating in the NCAA Division I, II, III Institution was collected by an Injury Surveillance System. The subjects reported any injuries attributed to sporting activity. The results showed no correlation between skill and the rate of ACL injury.

2.1.2. Mechanism of Injury

Communication with team trainers, coaches, or other eyewitnesses regarding the events surrounding the injury may be helpful in understanding the mechanism of injury. As the victims include athletes, injuries from falling, motor vehicle accidents, and work-related trauma, the mechanisms of the injury are somehow different. Most ACL injuries are low-velocity, deceleration, rotational injuries, and many are actually non-contact injuries (Noyes *et al* IN: Fu *et al*, 1994). Key factors are the patient's sport; positions played, and level of experience. The mechanism of tearing of the ACL ligament in the non-contact ACL injury, usually involves the knee being flexed with the foot planted while sudden forceful twisting motions are performed (Andrews *et al* IN: McLean, 1998; Zarins *et al*. IN: McLean, 1998). Typically the tibia is externally rotated with respect to the femur, causing the ACL to tighten by impinging on the lateral femoral condyle. In other words, the most common mechanisms of injury are valgus/external rotation, hyperextension, deceleration, and rotational manoeuvres. Varus mechanisms, although possible, are uncommon. The tensile and shear forces generated in the ACL during this action are thought to be of a magnitude sufficient to cause spontaneous failure of the substance ligament (Andrews *et al* IN: McLean, 1998) The exact mechanism of injury is difficult to define in many cases as patients often fail to remember specific details relating to their

⁴ The NCAA is a governing body for college athletics. The sports Injury Surveillance System is used to gather information about injury incidence in college athletics. The rate of injuries is kept in this system and the statistical and demographical information is provided.

injury when questioned some time later (Noyes *et al*, 1983). There is usually recollection of a specific traumatic episode associated with acute pain, inability to continue activity, rapidly developing knee swelling and an audible 'pop' (in 80% – 90%) at the time of injury (Noyes *et al*, 1983; Hawkins *et al*, 1986; Fu *et al*, 1994).

Kennedy *et al* (1974) described a few possible circumstances that resulted in ACL rupture but direct posterior violence was the only mechanism that produced an isolated lesion in a cadaver model. A clinical example was described, however, in which forced internal tibial rotation produced an isolated lesion in a skier. Wang *et al* (1975) examined a videotape recording of the incident and reported the exact mechanism of an isolated ACL rupture in an American footballer. The injury occurred as a consequence of a valgus force applied to a hyper-extended weight-bearing limb in slight internal rotation. It was concluded that hyperextension and internal rotation were the most likely cause of an isolated lesion, with hyperextension being the major component. The symptom of "giving way", or instability, is usually noted immediately after the injury. Due to hyper vascularity of the ligament in the presence of a rapidly developing knee effusion, which is the index for suspicion of a haemarthrosis, the possibility of an ACL tear is high.

2.1.3. The Fate of ACL-Deficient Knee Subjects

Due to the variability of a patient's impairment after an ACL injury, there is controversy over the condition of ACL-deficient knee patients following injury. Many patients are left disabled for sport which others appear to have minimal impairment. Some patients develop secondary meniscal tears, degenerative arthritis of the knee, and the incidence of a late meniscal tear after an ACL injury, all of which have been documented in the literature (Andersson *et al*, 1989; Hawkins, 1994; Sommerlath, 1994). Others show little joint deterioration. The ultimate goal for full restoration of an ACL-injured knee is returning the knee to its pre-injury level. By advancements in the knowledge of the anatomy, kinesiology and physiology of the ACL, further treatment of the ACL-deficient knee should be improved. Noyes *et al* (1983) announced "the role of third", in which 1/3 of ACL-deficient knee patients will continue to participate in their desired sporting at pre-injury levels (36%); 1/3 will be satisfied and continuing at a less vigorous level after physiotherapy and functional bracing (32%); and 1/3 will experience instability with conservative treatment and physiotherapy, and are candidates for surgical intervention (32%). Noyes *et al* (1983) also recognised considerable functional loss in a group of

athletically active individuals, to the extent that 65% were unable to participate in strenuous sporting activities at a mean follow-up of 5.5 years following injury. In addition, 50% described moderate to severe knee pain, and 34% moderate or severe swelling.

Dye (1996) divided the treatment of ACL injury into non-surgical and surgical areas. In the surgical area, the genetic manipulation inducing regeneration of tissues may be possible in the longer-term as the ultimate goal for full restoration of an ACL-deficient knee to pre-injury status. In the medium-term future reasonable stunts with incorporated bioactive growth factors have the potential for inducing normal ACL anatomy without the need for detrimental harvesting of the patient's tissues, or the risk of microbial transmission with the use of an allograft. In the near future, the development of more benign autografts and allografts, 3-D arthroscopic visualisation and robotic surgical techniques are all possible, along with methods of reasonable fixation of the graft to bone. In the non-surgical area, advancements in treatment should concentrate on the control of muscle atrophy, enhancing cerebellar-proprioceptive rehabilitation, and better bracing techniques. Finally, the author emphasised the maximisation of the functional load acceptance and transference capacity of the knee with the least degree of risk to the patient.

2.2. Biomechanical Studies in ACL-Injured Knees

Biomechanics is defined as "the study of the mechanical laws relating to the movement or structure of living organisms" (*Oxford Dictionary, 1990*). This involves the study of dynamics, defined as "the branch of mechanics concerned with the motion of bodies under the action of forces", and kinematics, defined as "the branch of mechanics concerned with the motion of objects without reference to the forces that cause motion" (*Oxford Dictionary, 1990*). Kinematics involves the study of the geometry of motion in a material body with two or more moving components. Such a component is termed a kinematic link, and represents the basic element of a kinematic system.

2.2.1. "In vitro (Cadaveric)" Studies

Having implanted specific transducers into the intact ACL, some researchers have studied the ACL behaviour in cadaveric specimens. To measure the forces applied to the ACL directly, Paulos et al (1980) inserted a buckle transducer into the ACL on a single cadaver joint. They reported that when the knee begins to extend from flexion, the ACL

strain starts to increase at approximately 30° of flexion, and the maximum forces occur during full extension.

Using similar method, Arms et al (1984) found that even passive knee flexion increased the strains in the antero-medial bands of the ACL from 0 to 35°. They reported that further flexion decreased the strain in the ligament to a maximum of 1.25% of the calibrated base line at a 120°. During the first 45° of flexion the antero-medial bands of AC strain increased to above the normal resting level when the subjects carried out isometric or concentric contraction. The strain in the postero-lateral bands of the ACL decreased immediately from 0° extension, with marked laxity between 15 to 70° of flexion. Applying the anterior draw test increased the strain in the ACL above the passive normal by approximately 60% of the calibrated base line.

To compare the active and passive ACL strain pattern, Renstrom et al (1992) studied seven cadaver knees and measured their ACL strain on passive knee extension as a base line. When the quadriceps muscle was activated alone, the ACL strain significantly increased relative to the passive normal strain at flexion angles from 0 to 45°. When the knee flexion exceeded beyond 75°, the quadriceps decreased ACL strain relative to the passive normal. However, acting alone, the simulated isometric hamstring activity decreased strain relative to the passive normal strain at all positions tested. The loads applied for the quadriceps and hamstrings were 400N and 250N respectively. Simulated isometric activity during simultaneous isometric quadriceps activity significantly reduced ACL strain between 30° to 90°. However, at 0° to 15° of flexion the simulated isometric hamstring activity during simultaneous quadriceps activity reduced the strain in the ACL as compared to the quadriceps activity alone, but not significantly. They, therefore, deduced that the antagonist effects on ACL strain by the quadriceps cannot be masked by simultaneous isometric hamstring contractions between 0° and 30°.

To determine the effect of hamstring antagonist co-contraction on the stability of the knee joint during isometric knee extension, Hirokawa et al (1992) used a computerised radiographic technique on 12 cadaver specimens. No antero-posterior displacement of the tibia was found in 0 to 120° flexion with zero load in the hamstrings and the quadriceps. The quadriceps was loaded at 120N at 15° flexion intervals. They

then added a co-contraction load to the hamstrings and increased it (20, 40 and 60 Newtons). When the quadriceps was contracted alone, 5-mm displacement occurred at 15° peaking to 6.5-mm at 30° of flexion. When the flexion angle exceeded than 45°, the anterior displacement gradually decreased. A mild posterior displacement of the tibia occurred at flexion ranging from 80 to 120° when there was an isolated quadriceps load. There was less than 1-mm anterior displacement of the tibia in full extension. In the ranges near full extension (0 to 15°), hamstring co-contraction did not have any impact on the anterior displacement of the tibia. Hamstring co-activation also reduced the rotation of the tibia elicited by contraction of the quadriceps. They also reported that the hamstring co-contraction decreases anterior and rotatory displacement of the tibia between 15 to 90° of flexion, and is ineffective between 0° to 15° of flexion. It can be concluded that *in vitro* studies confirm the ACL as the main restraint in anterior tibial displacement, and emphasise that the kinematics of the knee is clearly altered in ACL-deficient knees, although controversy exist regarding the changes which occur in the injured knee.

2.2.2. "In vivo" Studies

Biomechanical Analysis of the Normal and ACL-Deficient Knee

The "pioneers" of gait analysis on patients with ACL-deficient knees were probably Carlsoo and Nordstrand (IN: Branch *et al*, 1989). They studied five ACL-deficient subjects and compared the results with five normal knee subjects. They used an electrogoniometer for kinematic, forceplate for force and needle electrodes for EMG studies. They found a smaller range of knee motion (ROM) in the ACL-deficient group, but reported no significant difference in the muscle co-ordination and forces between the two groups. Shiavi *et al* (1987) used a six-degree of freedom goniometer, and studied the kinematic changes of eight healthy and seven matched ACL-deficient knee subjects during walking and pivoting. The foot contact pattern and the direct flexion/extension, abduction/adduction, and internal/external rotation, and the displacements between the tibia and the femoral coordinate systems, were measured and the helical motion analysis of the tibia with respect to the femur was studied. The results showed that the kinematics for free and fast speed walking are very similar, and also the kinematics of conventional pivoting and pivoting with a planted foot are very similar. They found the knee to be a dynamic joint, whose kinematic behaviour changes over the strider, that it is neither a hinge nor a planar joint, and that ACL-deficiency posed some significant changes in

kinematics of the injured knee, including an increased adduction and external rotation period of the stride. They also concluded that the range of translation of the tibia in the medial-lateral direction is reduced, and its mean translation is more medial. The ACL-deficient limbs were found to be less flexed and more adducted during mid-stance. During pivoting flexion was reduced at all times in the injured limb.

The translation of the tibia relative to the femur usually occurs in normal tibio-femoral movement. Knee flexion is actually a combination of rolling or rotation of the femoral condyles over the tibial plateau, and posterior gliding of the condyles along the plateau, which is anterior tibial translation (Muller, 1988). As the true flexion angle increases, this gliding or translational motion theoretically assumes an increasing proportion due to the shape of the femoral condyles. While the increased anterior translation seen in the ACL deficient knees might be expected to occur, during the stance phase it may minimise the amount of translation seen. In addition, when ligamentous instability exists these translational components may become even larger and play a more important role in total knee motion. However, these results must be interpreted with caution due to the poor accuracy of the apparatus used to measure small displacements.

Most *in vivo* kinematic studies have been conducted in ACL-deficient knees to compare the tibial translation in the ACL-deficient knee subjects with that of the normal knee subjects. Electrogoniometer has frequently been used to measure the anterior-Posterior (A-P) translation of the tibia relative to the femur in the ACL-deficient knees. Marans et al (1989) used an electrogoniometer and measured the A-P translation of the tibia in 20 ACL-deficient limbs, and compared them with those in 30 normal subjects during walking on level ground. They found a mean of 15.8-mm A-P translation in ACL-deficient subjects, which was significantly different from 7.6 mm A-P translation in normal subjects. The mean inter-limb difference between the injured and non-injured knee in ACL-deficient subjects was 4.7 mm, as statistically significant. These amplitude differences in anterior translation were noted to occur during the swing phase.

Vergis and Gillquist (1998) used an advanced electrogoniometer system and measured the tibial translation during ascending and descending stair climbing. The purpose of this study was to compare the sagittal translation of the knee in the patients with ACL-deficient injury with that in the control subjects during concentric and eccentric quadriceps muscle activity during stair walking. The test was carried out in both straight

and side ascent and descent walking. As a result, in both groups during the ascent cycle the tibia moved anteriorly in relation to the femur, whereas during the descent cycle it moved posteriorly. The maximum tibial movement was in a very wide range, between 1 to 12 mm (mean 7mm), in both groups. Although the maximal translation in both groups was similar, in the ACL-deficient group it occurred at a significantly smaller flexion angle ($38^{\circ}\pm 8$ relative to $44^{\circ}\pm 8$). There was no difference between the translation during step ascent and descent in the groups. They concluded that during normal activity, the ACL-deficient patients were able to control abnormal anterior translation.

Direct and invasive *in vivo* measurement of the tibia relative to the femur has an advantage of excluding skin movement artefacts, and is a very useful method in gait research using an electrogoniometer. In 1997, Ishii et al (1997) three-dimensionally measured the kinematics of the knee joint directly from inserted intra-cortical pin fixation. To exclude the effect of skin movement relative to the bone, and to exclude the effect of changing muscle volume, they implanted some Kirschner wires into the bone of five healthy male volunteers and determined an accurate description of the relative angular and linear movements between tibia and femur. The clinical motions were determined as: abduction/adduction (3.4 ± 1.2), internal/external rotation (10.6 ± 2.8 degrees) representing screw home motion, and three translation measures which were: anterior-posterior displacement (5.2 ± 1.7 mm) representing roll back phenomenon, proximal-distal (1.2 ± 2.7 mm) and medial-lateral (1.1 ± 2.6 mm). An identical study was conducted by Lafortune et al (1992) in order to gain a better understanding of the kinematics of the knee joint during walking on level ground. They investigated five normal subjects *in vivo*, and obtained the three coordinate axes of knee motion by inserting special metal-covered wooden spheres. Four high-speed cine cameras recorded 3-D coordinates of the target marker data at a speed of 1.2 m/sec. They measured all six degrees of freedom of the tibia and concluded that external rotation of the tibia, which is so called "Screw home movement", did not occur during the last swing phase of normal walking.

Jonsson et al (1989) carried out a 3-D invasive study to analyse knee movement with resisted extension exercise. By implanting three to five tantalum balls (0.8-mm diameter) percutaneously into the distal part of the femur, and proximal, of the tibia bilaterally, a serial roentgenographic examination (A-P and Lateral) was carried out in the ACL-deficient knee patients. The results showed that during the last 30 degrees of active knee

extension, the tibia internally rotates, followed by an external rotation, concomitant with an abducted knee. The inter-condylar eminence of the tibia displaced laterally (valgus), distally (distraction) and anteriorly. They concluded that absence of the ACL probably does not significantly change the tibial rotations, but may cause a more pronounced distal and anterior-posterior translation of the tibia.

In a static *in vivo* study, the average of anterior tibial displacement in different angles of knee flexion in the ACL-deficient knee was measured and compared with the normal side of the same subject by Bagger et al (1992). At 15° of flexion it was 7.8 and 3.3 mm respectively, and was significantly different from each other. At 45° and 90° of flexion, the increase in anterior tibial translation was not significant. When the subjects voluntarily contracted their hamstring with maximal contraction, the anterior tibial translation was significantly reduced when compared to the relaxed knee in all degrees of flexion. They concluded that hamstring activity has a positive effect on stabilising the knee joint.

The altered kinematics in ACL-deficient knees have already been demonstrated during knee extension, level walking or during quadriceps-powered knee motion (Shiavi *et al*, 1987; Jonsson *et al* 1989). The functional ability of the ACL-deficient subjects is not similar in all subjects. While some patients are physically active, and are even able to continue their previous forceful activities, others feel very disabled and should be limited to low force activities. Rudolph et al (1998) studied the 3D kinematic and kinetic differences between two groups of ACL-deficient patients with different functional ability. They divided the patients into two groups: the non-copers group, who had instability with daily activities, and the copers group, who had returned to all of their pre-injury activity levels. Five cameras using a passive 3-D motion analysis system (VICON, Oxford Metrics) recorded the kinematic variables during walking, jogging and step activities. Kinetic data was collected using a six component force platform. Results showed that the non-copers group had less knee flexion in the involved limb, which was not correlated to quadriceps femoris muscle atrophy. In this study, the copers group demonstrated joint kinematics similar to that of their intact knees, and similar to knee motion reported in uninjured subjects. They concluded that due to utilising an unsuccessful stabilisation strategy, which stiffens their knee joint, the non-copers subjects are at the potential risk of articular surface damage. However, the copers group

subjects use a strategy allowing them normal knee kinematics with safe pressure on the joint.

As it can be seen, there is an inconsistency in the literature regarding the amounts of the translatory measurements of the tibia with respect to the femur in the knee joint. The most accurate data showing tibial-related movement comes from the studies carried out using an invasive *in vivo* method via intra-cortical pins. LaFortune et al (1992) and Karrholm (1989) measured the translatory kinematics of the tibia and found different results. Karrholm et al (1989) used a Roentgen stereo-photogrammetry⁵ to measure 3D movements of the knee during A-P laxity test in ACL-deficient subjects and cadaver knees. Thirty-three ACL-deficient subjects and three cadaver knees at 30 degrees flexion were studied, and the translatory kinematics were recorded. In intact cadaveric knees, the anterior laxity (1.3 and 5.6 mm) was greater than the posterior (-0.2 and -0.9 mm). When the ACL ligament was cut, anterior displacement increased to slightly more than 9 mm in the two knees, and the posterior displacement to -0.7 and 2.5 mm. The A-P translation increased from 2.6 and 6.1 mm to 9.8 and 11.8 mm after the ligament had been sectioned. The ACL-deficient patients had at least 3.1-mm anterior displacement (mean 7.7 mm), while the posterior displacements were equal on the injured and the intact side. All ACL-deficient subjects displayed an increased anterior laxity of at least 4 mm (average 8.1 mm), and the average difference between the injured and the intact knee was 2.1 ± 1 mm greater in the group of patients with associated injuries ($P < 0.05$).

Lafortune et al (1992) discovered a distinct relationship between knee flexion-extension and tibial translations along all three femoral orthogonal axes. Regarding anterior-posterior drawer movement along the floating axis, the tibia was drawn posteriorly when the knee was flexed, and it moved anteriorly during extension. Posterior drawer amounted to 3.6 mm during the first half of stance, while knee extension was associated with a maximum anterior displacement of 1.3 mm past the neutral position, defined as 0.0 mm.

In brief, most studies in ACL-deficient knee which have been carried out are *in vitro* or static *in vivo*, and mainly demonstrated more A-P tibial displacement in the ACL-deficient knee when the knee is around 30-40° of flexion. In most of these studies, a non-optic/optoelectronic device has been used. Because of the importance of the translatory

⁵ In this method, stereo-photographs were taken from the lateral and anterior views. Both femoral and tibial target markers were digitised in addition to anatomical points of interest.

kinematics of the knee joint in this study, more extensive literature will be reviewed at the end of this Chapter.

Use of Treadmill in Kinematic Studies

Walking and running on the treadmill is a convenient method for exercise testing and scientific research. Studies using a treadmill allow for a controlled environment and can, therefore, be used for locomotion research. Every type of study on the ground, including metabolic, electromyographic and biomechanical studies, can also be carried out on the treadmill. During walking on the treadmill, the pattern of walking is somehow different from walking on level ground (Nigg *et al*, 1995). On a treadmill the surface is moving and the subjects must acclimatise themselves with the new environment, which seems to be more difficult than that of walking on level ground.

One of the sources of variation between treadmill and overground running, and the inconsistent findings in the literature, might be related to the different types of treadmill used (Nigg and Cole, IN Ramsey *et al*, 1999; Nigg *et al*, 1995). Two aspects dealing with the treadmill itself are discussed in the literature. Firstly, the treadmill must have a strong enough driving mechanism so that the energy transfer between the subject and the belt is minimised (Ingen and Van IN: Nigg, 1995; Winter *et al*, IN: Nigg, 1995). Secondly, the construction of the treadmill must be so that the perceptual information during treadmill running is close to that received during overground running (Schmidth IN: Nigg, 1995). The sense of balance can be influenced by design factors such as running surface size, height of the treadmill, and a railing for support. It is speculated that larger, more expensive treadmills, typically designed for research and high-performance testing, fulfil these requirements to a greater extent than smaller and less expensive treadmills typically designed for physical fitness-related situations. They speculated that compared with overground running, the running style will change while running on a smaller treadmill than on a larger treadmill.

Some research has been carried out by using a treadmill during running at different speeds. Siler *et al* (1997) carried out a test to define whether or not grasping handrails during treadmill walking affects sagittal plane kinematics. They tested 15 normal subjects and asked them to walk on a treadmill in both grasped and non-grasped (free) handrail bouts and some kinematic parameters on the hip/knee/ankle joints were measured. The results showed that grasping of the treadmill resulted in a variety of changes in individual status including decreasing the heart rate, increasing the maximal

time-walked on the treadmill. However, it did not significantly alter changes on the sagittal plane kinematics of the knee during walking on the treadmill while grasping the handrails. They concluded that subjects might grasp the treadmill handrails without affecting the sagittal plane kinematic parameters of walking style.

To compare the effects of increased speed and inclination of the treadmill on muscle activities during walking on the treadmill, Kaulan et al (1990) studied nine ACL-deficient and nine matched normal subjects during walking on the treadmill at 0 and 25 degree inclines at speeds of 2.5 and 4 kilometres. They reported that with increasing the treadmill incline from 0 to 25° all muscles activated closer to heel contact. When walking on a horizontal level no significance was found in the relative onset times between the recorded muscles in ACL-deficient patients and the controls at both speeds. However, when the patients were walking uphill, the activity in all of the recorded muscle groups commenced earlier. However, this difference reached significance only in the hamstrings. This earlier recruitment of the hamstring muscles in ACL deficient patient could be a compensation for the lost resistance normally given by the ACL during the extension of the knee before heel contact, thus increasing stability.

EMG Studies in ACL-deficiency

Introduction

Methods of measuring electrical signals from human muscles were greatly simplified by the introduction of the metal surface electrode in 1907 by Piper. A significant advance for clinical electromyography was made by the development of silver/silver chloride and fine-wire electrodes in the late 1950s, resulting in an increase in the use of EMG for kinesiological studies. In the ACL-deficient knees, it is believed that the behaviour of the muscles around the knee joint might be changed due to the altered kinematics.

Some pure EMG (Kalund *et al*, 1990; Lass *et al*, 1991; Branch *et al*, 1989) or mixed EMG studies with other kinetic or kinematic devices (Limbird *et al*, 1988; Beard *et al*, 1996; Roberts *et al*, 1999) have been carried out in order to obtain a better understanding of the biomechanics of the ACL-deficient knee. Limbird et al (1988) studied the electromyographic findings in 12 ACL-deficient patients and compared the results with 15 normal knee subjects. They found that the majority of the significant differences in the rectified and filtered linear envelope profiles between the normal and ACL-deficient

subjects occurred during the two transition periods: heel contact and toe-off. At heel contact they reported less muscle activity in the rectus femoris, vastus lateralis and gastrocnemius muscles, and more activity in the biceps femoris muscle in ACL-deficient subjects. At toe off two types of behaviour seem to be occurring. At heel off (about 50% of the gait cycle), all of the thigh muscles had baseline activity. However, during the remainder of the transitional period the quadriceps muscles had greater activity and the hamstring muscles showed less activity than normal. Therefore, when the support is shifted from the injured to the contralateral extremity, there is a brief period when the ACL-deficient knee joint experiences minimal muscular stress.

Lass et al (1991) were probably the first who emphasised the importance of the gastrocnemius muscle in the ACL-deficient knees. Fourteen arthroscopically confirmed ACL-deficient patients and sixteen normal knee subjects were selected by Lass and the EMG findings of the muscles on the knee were studied during fast walking on the treadmill at 1.36m/sec (5Km/hr). The EMG and heel contact signals were recorded on a PC and displayed. They reported earlier EMG activity of the gastrocnemius and the lateral hamstrings in the ACL-deficient group, and confirmed that the onset activation time of the gastrocnemius was decreased at up to 6% of the gait cycle. In addition, the duration of EMG bursts of the vastus medialis and the gastrocnemius muscles were statistically different and had been prolonged by 8% and 5% of the gait cycle, respectively. The root mean square (RMS) of the EMG amplitude of all the muscles increased too. Based on these findings, they realised that earlier activation and a general tendency to prolonged activity in all the muscles were compensatory for an unstable knee. The earlier onset of the hamstrings was considered to stabilise the knee in preparation for foot contact with the ground, decreasing the risk of subluxation. They emphasised that the increased gastrocnemius action could be an attempt to stabilise the knee joint, which is otherwise susceptible to subluxation. Finally, they reported that simultaneous contraction of the knee muscles is an important factor in increasing the stiffness of the knee joint at an average of 2 to 4 times (Markolf *et al*, 1978).

In a very interesting study demonstrating the importance of the gastrocnemius role in the ACL-deficient knee, Sinkjaer and Arendt-Nielsen (1991) repeated the same study as Lass et al (1991) and re-confirmed that the mean EMG onset time of the hamstrings and the gastrocnemius occurred earlier in the gait cycle and the duration tended to be prolonged in the former group. They used the Lysholm scoring system (Lysholm and

Gillquist, 1982) and divided their ACL-deficient subjects into two groups: above and below than 84. The score of 84 and above signified a good function while the score below 84 was considered poor (Friden *et al*, 1990). They found a significant difference in onset and duration of EMG activity between the two groups in the gastrocnemius muscle alone. The gastrocnemius muscle recruited earlier and remained active throughout stance phase until heel-off. They selected two ACL-deficient subjects with a Lysholm score of 67 and 70, respectively. They trained these patients for 15 weeks to recruit their gastrocnemius earlier by visual feedback. An earlier onset of the gastrocnemius was normally obtained by a slight inward rotation of the foot. The muscle contraction was stronger immediately after onset and the duration of muscle activity also increased. Interestingly, the Lysholm score of the first subject increased from 67 to 85 and the score for the second subject increased from 70 to 90. They concluded that the earlier recruitment and longer burst duration appears to be advantageous for the ACL-deficient knee and may be a compensatory mechanism. They also pointed out that the earlier onset of the hamstring muscles may stabilise the knee in preparation for foot contact.

To define whether or not ACL injury causes any changes to the electromyographic parameters during walking (free and fast speed walking), 46 normal and ACL-deficient knee subjects were investigated by Shiavi *et al* (1992). The subjects proceeded along a 12-meter walkway at either a self-selected free or fast walking pace and the EMG parameters of the muscles around the knee joint were recorded (Shiavi *et al*, 1992). The linear envelope of each knee joint's surrounding muscles in both normal and ACL-deficient knees in free and fast speed walking were recorded. The results showed that the injured subjects could exhibit typical EMG parameters and the uninjured subjects could exhibit an atypical pattern for walking. The results also demonstrated that the atypical patterns are much more prominent at fast walking speed. They also suggested that for rehabilitation treatment of the ACL injury, one must focus on developing regiments that include synergistic involvement of several muscles rather than one muscle such as hamstrings. Formerly, Murray (Murray *et al*. IN: Rudolph *et al*, 1998) reported that in normal subjects during slow, free and fast walking the amplitude of normalised EMG activity decreases as walking speed decreases. They also emphasised the speed of walking as an important factor on measurements of gait.

A linear envelope processed EMG study, carried out by Branch et al (1989), on 10 unilateral ACL-deficient and five normal control subjects showed a 30% decrease of the area under the curve and a 11% decrease of the peak EMG for the quadriceps during the stance phase of the cutting manoeuvre. The gastrocnemius showed a 12% decrease of area under the curve and 9% decrease in Peak EMG activity. However, the medial hamstring showed an increase of 46% in the area under the curve and 36% increase in peak EMG activity. They reported that the medial hamstring muscle was an important antagonist to the pathologic anterior draw created by active quadriceps contractions. They assumed that since the quadriceps and the gastrocnemius activities tended to increase the anterior draw of the tibia on the femur, decreased quadriceps and gastrocnemius activity is beneficial for the ACL-deficient knee. However, hamstring activity leads to decrease anterior draw, thus protecting the ACL-deficient knee.

The EMG findings of the ACL-deficient knee muscles, with emphasis on the related knee flexion angle during a gait cycle, were investigated using a 3-D VICON gait analysis system. Eighteen ACL-deficient patients and nine matched healthy control subjects were recruited in a study conducted by Beard et al (1996) and their gait was assessed. Simultaneous EMG of the lower extremity muscles was recorded by surface electromyography. For each section of the stance phase, minimum knee flexion angle and activity duration of leg musculature was calculated. In the ACL-deficient group, the minimum flexion angle at heel contact and mid-stance was larger than that in the control group. An increased hamstring activity was recorded throughout stance phase, but the quadriceps muscle activity duration was similar in both groups. They found that the duration of hamstring activity correlated with the flexion angle at foot contact. They concluded that the "net increase in internal flexion moment", reported in the previous literature, may not necessarily be due to decreased activity of the quadriceps and may be due to increase in hamstring activity.

NB: At the end of each section, a summary of the studies reviewed has been chronologically shown in Tables. The details of some studies have been mentioned in the Tables while they have not been reviewed in the text.

Table 2-1 shows a summary of kinematic studies in ACL-deficient knees.

Table 2-2 shows a summary of EMG studies carried out on ACL-deficient knees.

Table 2-1 Summary of the Studies in Kinematics of the ACL-Deficient Knee.

Researcher(s)	Year	Study	Instrumentation	Results
Carlsoo <i>et al</i>	1968	To determine the biomechanical differences between normal and ACL-deficient knees.	Electrogoniometer , force plate and needle EMG	-Decreased knee ROM in ACL- deficient subjects. - No difference in force or EMG recorded between normal and ACL-deficient subjects.
Paulos <i>et al</i>	1980	To measure the strain forces applied to the ACL (<i>in vitro</i>)	Inserting bucket transducers into the intact ACL.	The ACL strain began to increase at ~ 30° of flexion and peaked at full extension.
Arms <i>et al</i>	1984	To measure the strain forces applied to the ACL (<i>in vitro</i>)	Inserting bucket transducers into the intact ACL.	-Even passive motion increased the ACL strain in antero-medial bundles from 0-35°. -An isometric concentric quadriceps contraction increased the strain in the first 45° of flexion. -Application of the anterior drawer test increased the ACL strain by 60%.
Marran <i>et al</i>	1985	Measurement of A-P displacement of the tibia in normal and ACL-deficient subjects.	Electrogoniometer	A mean of 15.8-mm A-P displacement was found in ACL-deficient and 7.6-mm in normal knees.
Renstrom <i>et al</i>	1986	Comparison of the active and passive ACL strain pattern (<i>in vitro</i>)	Inserting bucket transducers into the intact ACL	-When the quadriceps was activated alone, the ACL strain was greater when compared to the passive normal situation at 0 - 45°. -In flexion of more than 75°, the quadriceps activity decreased ACL strain. -Simultaneous activity of the quadriceps and hamstring muscles reduced ACL strain in 30-90° of knee flexion.
Shiavi <i>et al</i>	1987	To determine the biomechanical differences between the normal and ACL-deficient knees.	A six-degree of freedom goniometer.	-ACL-deficiency posed significant difference in kinematics findings. -ACL-deficient subjects had less knee flexion but more adduction.

Table 2-1 Summary of the Studies in Kinematics of the ACL-Deficient Knee. – cont.

Researcher(s)	Year	Study	Instrumentation	Results
Jonsson <i>et al</i>	1989	3-D analysis of knee movement with resisted extension exercise in ACL-def. and normal subjects.	Serial Roentgenographic technique.	-The "Screw Home Movement" occurred during last 30° of extension. -ACL-deficiency does not change knee rotation, but changes knee A-P displacement.
Gehlsen <i>et al</i>	1989	3-D kinematics of the knee during running on different surfaces and gradients.	Tri-axial Elgon	Significant differences occurred due to different surface and gradients.
Hirokawa <i>et al</i>	1991	The effects of hamstring co-contraction on the stability of the knee joint during isometric extension.	Radiographic technique.	The co-contraction decreased anterior and rotatory displacement of the tibia between 15 and 90°, but was ineffective between 0-15°.
Lafortune <i>et al</i>	1992	Studying 3D kinematics of the normal knee by inserted intra-cortical pins. (<i>in vivo</i>)	Four High-speed cine cameras	-All six degrees of freedom were measured <i>in vivo</i> . -The "Screw Home Movement" did not occur.
Bagger <i>et al</i>	1992	Comparison of A-P displacement between normal and ACL-def. sides.	Acufex KSS Laxity Tester	-A-P displacement was significantly higher in injured knee. -Hamstring activity played a major role on knee stability.
Siler <i>et al</i>	1997	The effects of grasping of the treadmill stand rail on knee kinematics.	3-D gait analysis system.	-Grasping has significant effects on heart rate, physiological index, etc. -However, it did not have any effect on sagittal knee kinematics.
Ishii <i>et al</i>	1997	Studying 3D kinematics of the normal knee by inserted intra-cortical pins. (<i>in vivo</i>)	3-D optoelectronic gait analysis system.	-All six degrees of freedom were measured. -The amount of A-P displacement was 5.2±1.7 mm.

Table 2-1 Summary of the Studies in Kinematics of the ACL-Deficient Knee. – cont.

Researcher(s)	Year	Study	Instrumentation	Results
Rudolph <i>et al</i>	1998	To determine the functional ability in two groups of ACL-deficient subjects.	3D gait analysis system.	-Only the “copers” (and not “non-copers”) demonstrated a joint kinematics similar to normal knee. -The “non-copers” are in potential risk of articular surface damage.
Vergis <i>et al</i>	1998	Measurement of A-P displacement of the tibia during ascending and descending stair climbing.	Electrogoniometer	-Both ACL-deficient and normal groups showed the same level of A-P displacement. -ACL-deficient subjects had lower knee ROM. -ACL-deficient subjects were able to control the abnormal anterior translation.

Table 2-2 Summary of EMG Studies in the ACL-Deficient Knee.

Researcher(s)	Year	Study	Instrumentation	Results
Murray <i>et al</i>	1984	The study of the EMG parameter in normal knees.	EMG	They found a relationship between the speed of walking/running and the amplitude of normalised EMG activity.
Limbird <i>et al</i>	1988	The EMG findings of knee muscles in normal and ACL-deficient knee	EMG	The majority of EMG differences between normal and ACL-deficient subjects occurred at two stages: heel contact and toe-off.
Branch <i>et al</i>	1989	The EMG findings of knee muscles in normal and ACL-deficient knee during cutting manoeuvre.	EMG	-In ACL-deficient, both gastrocnemius and quadriceps had lower EMG activities. -Only medial hamstring showed higher EMG activity, which was compensatory for ACL-deficiency.
Kalund <i>et al</i>	1990	To determine the effects of increasing speed and inclination during walking on the treadmill.	EMG	-The muscles were activated earlier in both groups when the inclination increased. -Only in ACL-deficient group, the hamstring recruited earlier during uphill activity, which is compensatory.

Table 2-2 Summary of EMG Studies in the ACL-Deficient Knee. – cont.

Researcher(s)	Year	Study	Instrumentation	Results
Lass <i>et al</i>	1991	The EMG activity in ACL-def. subjects during walking on the treadmill with different gradients.	EMG	<ul style="list-style-type: none"> -The gastrocnemius and lateral hamstring in ACL-deficient subjects were activated earlier than those in normal subjects. -The duration and RMS of EMG signals of the vastus medialis and gastrocnemius were increased.-All lower extremity muscles were activated earlier. -Alteration of the gastrocnemius activity and time of activation have stability effects on the deficient knees.
Sinkjaer <i>et al</i>	1991	The EMG findings of knee muscles in normal and ACL-deficient knee	EMG	<ul style="list-style-type: none"> -The gastrocnemius and hamstring showed a higher duration and were activated significantly earlier. -In those ACL-deficient subjects with Lysholm score higher than 84, only the gastrocnemius was recruited earlier and remained active during the stance phase. -By training the ACL-deficient subjects to activate their gastrocnemius earlier, their Lysholm score can be increased.
Shiavi <i>et al</i>	1992	The EMG findings of knee muscles in normal and ACL-deficient knees in free and fast walking.	EMG	<ul style="list-style-type: none"> -ACL-deficient subjects may exhibit normal muscle activity and vice versa. -During rehabilitation, the synergistic involvement of the group muscles should be focused upon rather than an individual muscle such as the hamstring.
Beard <i>et al</i>	1996	The EMG finding of knee muscles in normal and ACL-deficient knee during walking on level ground.	EMG and VICON	<ul style="list-style-type: none"> -A correlation exists between the knee flexion angle at foot strike and the duration of hamstring muscle signals. -The net increased internal knee flexion moment (quadriceps avoidance gait) may not be due to reduced activity of the quadriceps muscles, but may be due to increased hamstring activity.

2.3. Bracing

Introduction

Over the last two decades, the number of bracing and taping (supports) has increased dramatically (Beynnon and Renstrom, 1991). In June 1984, the American Academy of Orthopaedic Surgeons (AAOS), Committee on Sports Medicine conducted a seminar on "Knee Bracing" (Podesta and Sherman, 1988). The aim of this seminar was to obtain data from manufacturers, physicians and bioengineers on the design and effectiveness of knee braces being manufactured. They published the conclusions of the seminar in 1985 in the AADS Knee Brace Seminar Report (American Academy of Orthopaedic Surgeons, 1985) and concluded that controversy exists with regard to the effectiveness of knee braces and that further epidemiological and biomechanical studies are needed. Years after this conclusion, there is an increase in the type of braces available and the above mentioned controversies still exist (Fleming *et al*, 2000; Ramsey *et al*, 2000; Rahimi and Wallace, 2000a).

The purpose of using an orthotic is to assist, restrict, align, or simulate function of a body part. Knee braces use elastic straps or springs to assist motion, stops or hinges are used to adjust a particular range of motion and an intrinsic design and construction is emphasised to align or simulate function of a body part. In contrast to the past routine use of braces for ACL-deficiency, it is now reserved for non-operative patients whom instability is reproduced in sports. According to the Decoster's survey, 61% of orthopaedic surgeons prescribe FKBs for at least $\frac{3}{4}$ of their non-surgical ACL-deficient patients. It is assumed that FKBs protect ACL-deficient knees through mechanical constraint of joint motion and improvement of proprioception (Lubliner and Jeffrey, 1997), although this is still controversial.

The AAOS Committee on Sports Medicine categorised the braces into three groups: prophylactic, rehabilitative, and functional (Figure 2-1).

Prophylactic Knee Braces: those braces designed to prevent or reduce the severity of knee injury (Beynnon and Renstrom, 1991).

Rehabilitative Knee Braces: those braces designed to allow the early controlled and protected motion to the injured knee treated surgically or non-surgically (Beynnon and Renstrom, 1991).

Functional Knee Braces (FKB): those braces designed to assist or provide stability to the knees suffer from an instability syndrome, usually resulting from the absence of one or more ligamentous structures, such as the anterior cruciate ligament (Beynnon and Renstrom, 1991).

NB: Some other braces available today combine two or more of these attributes and therefore cannot be strictly categorised

It is understood that despite unclear objective data existing to support brace efficacy, it is assumed that they promote improved performance in patients with ACL-deficient knees. Further work regarding objectiveness, proprioception, psychology, and the mechanical aspects of bracing is required.

Figure 2-1 Three Types of Knee Braces.

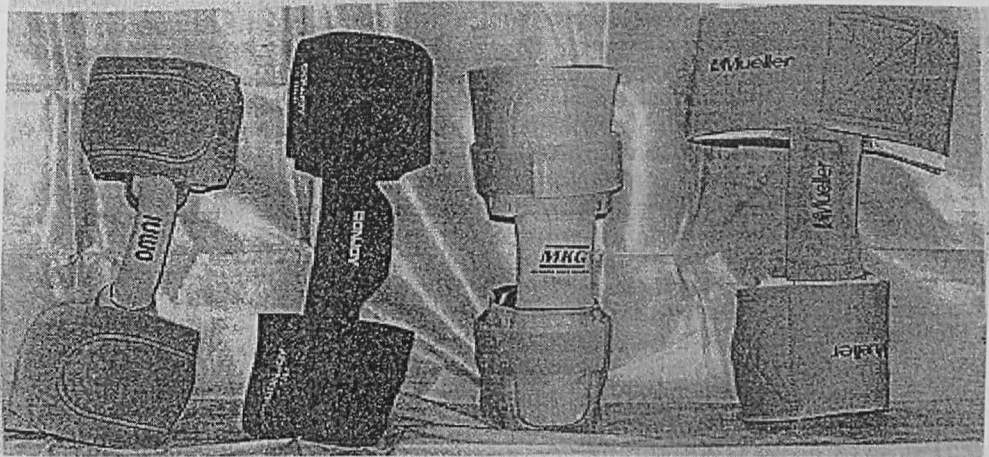

Examples of Prophylactic Knee Braces

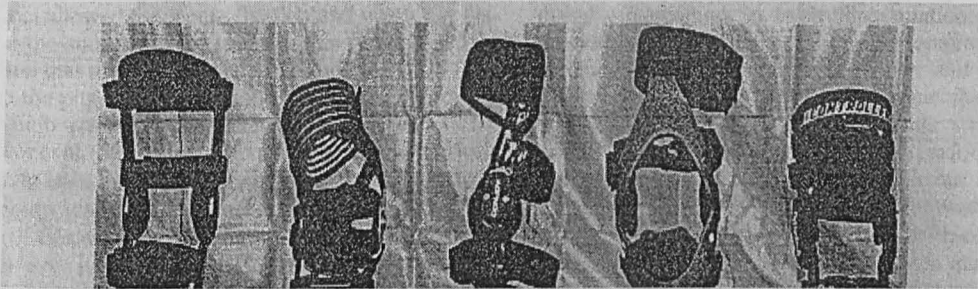



Examples of Functional Knee Braces

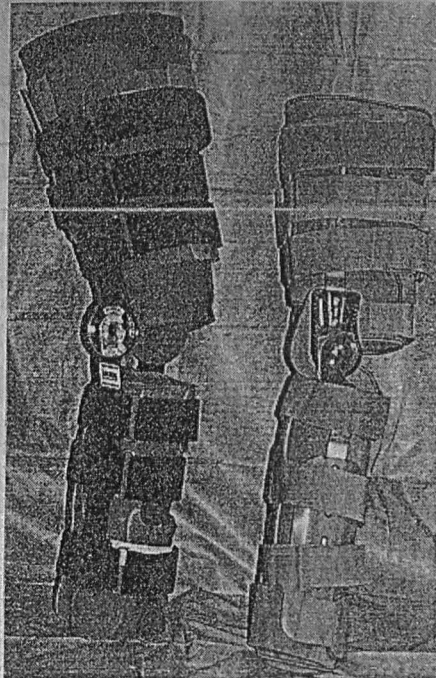

Example of Rehabilitative Knee Braces

2.4. Functional Knee Bracing

Currently, functional knee braces (FKBs) are used for ACL-deficient knees mostly pre-operatively and sometimes after ACL-reconstruction surgery to provide stability. The sports medicine community has developed an acceptance of knee bracing as a means of treating knee instability due to an injury of a knee ligament, such as the anterior cruciate ligament (Bondar *et al*, 1991; Colville *et al* IN: Beynnon *et al*, 1991; Millet *et al*, IN: Beynnon *et al*, 1991). Because of the unique structure of the knee joint, a unique challenge of functional bracing is the need to act against the compliant interface of the powerful limb muscle groups (e.g. hamstrings, quadriceps, gastrocnemius). Therefore, the FKBs must control both muscles and bony skeletal structures of the knee joint (muscles are the first line of defence for the knee joint) in which they are able to change surface profile whilst developing large forces that act through the long lever arms of the tibia and the femur. This combination of requirements produces a challenge for large tibio-femoral joint moments and loads, along with constantly changing lower limb profile that the braces must attach to in order to control tibio-femoral articulation.

The most important feature of a suitable FKB design is its ability to meet the challenge of controlling or restoring normal kinematic behaviour to the injured knee. Butler *et al* (1991) emphasised that while providing normal guided motion to the ligament deficient or injured knee, a FKB design must utilise leverage on the long axis of the lower limb to limit abnormal tibio-femoral motions that might be detrimental to the knee. To avoid the failure of FKBs against large load magnitude activities and to prevent abnormal kinematics, the connections between the brace and soft tissue surrounding the lower limb should be as rigid as possible. It must also provide a large surface area for attachment and conformity with the soft tissue contour profile. FKBs are the most popular form of knee brace because of the perceived benefit to the player with an unstable knee. The extent that the braces can relieve the pain symptoms is related to the severity of symptoms. In general, the more severely symptomatic the knee, the less likely they are to be symptom free in brace.

The ability of functional knee braces (FKBs) to increase stability of the knee by controlling tibial translation is still very unclear. Some literature emphasises that most FKBs may only protect the ACL at low loads, but not at high loads such as those expected during ADL or athletic competitions (Hirokawa *et al*, 1992; Bagger *et al*, 1992;

Beynnon and Renstrom, 1991; Beynnon *et al* 1999). There is still a controversy regarding if FKBs can improve the kinematics of the ACL-deficient knee towards a more normal and safer position. Much research is required to develop an effective FKB, which protects ligamentous structure and provides normal tibiofemoral kinematics at physiologically loaded limits, as there is a definite clinical application.

Because of similarity between prophylactic knee brace and FKB in the AAOS definition, Beynnon and Renstrom (1991) comprehensively defined FKB as:

“FKB is an orthosis designed to facilitate normal tibiofemoral joint kinematics while limiting abnormal displacement and loading which might detrimentally strain an injured ligament, a reconstructed replacement, a prosthetic replacement, or cause abnormal tibio-femoral subluxations in the ligament deficient knee” (Beynnon and Renstrom, 1991).

They also postulated that directly controlling tibio-femoral kinematics through attachment to a compliant and variable interface is essential for effective knee bracing, and for the prevention of abnormal joint kinematics associated with loading.

Knee sprains can be divided into three categories: grade I (mild with no laxity); grade II (moderate with slight laxity); grade III (severe with significant laxity or complete disruption of the ligament). A grade III sprain poses a threat to an individual's ability to return to previous levels of activity and sometimes surgical-reconstruction will be recommended (Hunter, 1990).

A FKB is frequently prescribed for an individual who has a grade II, III ACL sprain, complete rupture of the ACL or one who has undergone surgical reconstruction of the knee. The FKB provides extrinsic support of the knee to allow the person to return to vigorous activities. The main aim of using a FKB is to protect the knee against excessive internal or external forces.

In summary, FKBs are prescribed for two main reasons:

1. To reduce injuries to the unstable joints by adding an external stabilisation to the knee.
2. To offer the patients the possibility of participating in strenuous activities.

Although subjective results favouring bracing are plentiful, there is a lack of biomechanical support and objective proof for FKB as a tool to improve the

biomechanics of the impaired knee towards a safe and normal position. Some investigators have reported the effects of FKBs via the biomechanical studies quantifying tibial displacement. Numerous studies in this field have been carried out on cadaveric specimens and those used radiographic methods, stereophotogrammetric techniques, electrogoniometers, etc. to evaluate the effects of FKB on the ACL-deficient knees (Baker *et al*, 1991; Mortenson and Foreman IN: Cawley, 1991; Paulos *et al* IN: Cawley, 1991; Wojtys *et al*, 1987). In this study, the main emphasis is on reviewing the *in vivo* studies in which an optic/optoelectronic gait analysis device has been used.

2.5. Bracing of the ACL-Deficient Knee “A Review of the Literature”

Braces are often an essential part of treatment programmes for patients with pathology of the knee. The effect of bracing on muscular function still remains controversial. The following literature presents research findings of static brace studies, dynamic investigations and evaluates the kinematics, kinetics and EMG studies of the effects of bracing in ACL-deficient knees.

2.4.1. Static Brace Studies

The majority of FKBs currently marketed are designed to control A-P motion in ACL-deficient patients. The reports of the development of new FKBs must also be reviewed with care because success may be claimed without scientific justification. The effects of FKBs during static loading of the knee to control the tibial displacement have been studied in several laboratories.

Static clinical tests are valuable to some extent because they indicate the limits of functional bracing with active loading. Despite these limits and the fact that functional tests often reveal no measurable improvement with brace use, subjective patient response to bracing is generally positive.

Wojtys *et al* (1987) studied the biomechanical evaluation of the Lenox Hill knee brace on four cadaveric knees. They measured the amounts of anterior tibial translation and external rotation in either ACL-resected or ACL as well as medial and lateral collateral ligaments resected in the knee brace. The results showed that in the intact ligament knees, the brace had some limiting effects on the tibia when translational forces were applied to the tibia or when internal rotation forces were applied to the femur. In ACL-

deficient knees with 30 degrees knee flexion and no axial load application, the brace decreased translation significantly. When the medial collateral ligament as the secondary restraint was also resected, translation was not altered by brace application. In other words, although the medial fulcrum brace controls the ACL-deficient knee effectively, its efficacy may depend on intact medial secondary structures of the knee. They concluded that the Lenox Hill knee brace might be effective in decreasing anterior tibial translation in ACL-deficient knees if a medial fulcrum brace was used in knees with intact secondary medial restraints.

In another study Wojtyś and Lubert (1990), evaluated 14 braces in six cadaveric knees. They measured antero-posterior and rotational translations at 30° and 60°. The braces were able to limit tibiofemoral translation by 10 to 75% in antero-posterior translation. Rotational control varied widely and did not correlate with ability to limit motion in the sagittal plane. However, no proof of restraint of translations at physiologic loads was observed. The role of braces preventing anterior translations in high-load situations during sports has not been demonstrated and this agrees with Johnson and Bach's (1991) review of the literature on functional braces.

Having a small sample size and applying relatively low loads in an open-kinetic chain configuration, Beck et al (1986) tested seven FKBs on three ACL-deficient subjects. They used a KT-1000 instrumented device to measure the anterior displacement of the tibia relative to the femur in subjects with an ACL-deficient knee. They used the opposite knee of the subjects as control group. They also tested two braces with different designs with either hinge, post, and shell design and hinge, post, or strap design. They applied an 89N anterior drawer, 89N total, maximum anterior drawer, and an active anterior drawer test when the subjects' knees were placed at 25° of flexion. No significant difference was found between the braces in controlling the anterior tibial displacement. They ranked braces with the hinge, post, and shell design as more effective than the hinge, post, and strap design. They concluded that the braces were effective at controlling anterior tibia displacement at low load (89N). As the load increased, however, the effectiveness of the brace decreased.

The similar test was carried out by Colville et al (1991) using Lenox-Hill FKB and the same results were reported. They reconfirmed that the Lenox-Hill brace did control the anterior tibial displacement at only low loads (100N), but was not effective at maximum

anterior drawer force. All of the same subjects in this study had subjectively reported that the brace was very effective in preventing the “giving way” of their knees.

A statistically significant decrease was reported in anterior tibial displacement by Rink et al (1989) at only low loads (89N). Fourteen subjects, none of elite athletic status, with arthroscopically proven anterior cruciate deficient knees were selected. The subjects evaluated three types of braces for one-month periods each, and then underwent testing with physical examinations, KT-1000 arthrometry, and timed running events. All braces reduced subjective symptoms of knee instability. They pointed out that as the forces increased, the brace effectiveness decreased. The subjects participating in this study also reported a very good stability and improvement during the athletic performance when the brace was worn. However, no objective improvement was found in the results of a timed 18.3-meter sprint and figure of eight run with and without a brace.

In contrast to the studies reviewed above, Beynnon et al (1992) implanted a Hall Effect Strain Transducer (HEST) in the ACL of five males with normal knees and the effect of shear loading on the braced and non-braced conditions was evaluated. A shear load at 10 increments from 10 to 200N was applied to the tibia when the knee was stabilised at 30° of flexion. They found no change in ACL strain between the brace and no-brace conditions. Then, they measured the ACL strain during active range of motion, and again found no change between conditions. They concluded that, during a *static* shear loading of normal knee, bracing has no effects on *in vivo* ACL ligament strain.

In brief, most static studies showed a positive effect of FKB in controlling anterior tibial translation in low loads (\downarrow 100N) forces. Although there are some advantages in carrying out static studies, they do not reveal the real muscular reactions during daily activities and the more attention should be drawn to dynamic studies.

2.5.2. Dynamic Brace Studies

The studies summarised in this section are of value because they describe dynamic functional tests, which employ closed chain kinematics with a loaded knee to assess brace performance, whereas many clinical tests rely on static data generated at one knee angular position to evaluate brace function.

The use of gait analysis parameters (kinetic, kinematic and EMG) on normal and ACL-deficient knees with and without a FKB is another type of investigation that has been

carried out to understand the efficacy of FKBs on ACL-deficient knees (Inglehart IN: Cawley, 1991; DeVita *et al*, 1998; Ramsey *et al*, 2000). The research studies in this field were initiated by Knutzen *et al* (1983) performing an overground straight running test on ACL-deficient subjects with and without a FKB and an elastic support brace.

Using an electrogoniometer, they measured the 3D angular positions of the knee joint during the task. Seven subjects had previously undergone surgery for ACL or meniscal damage. The healthy contralateral limb was considered as the control group and a derotation brace was prescribed for the involved limb. The subjects were randomly tested in four conditions including testing the healthy limb, involved limb, and involved limb with the brace as well as involved limb with the elastic sleeve. During the tests, the brace and the electrogoniometer were checked regularly and the data of five trials at a pace of 3.35 to 3.58 m/sec were collected. The maximum knee flexion at swing, maximum stance flexion (during single-limb support), maximum external tibial rotation (at the end of swing) and maximum internal tibial rotation (during stance) were measured and compared with the control group. The results showed that use of the derotation brace tended to restrict flexion angle in both swing and stance phases, although the changes were significant only in swing phase. The use of the derotation brace significantly reduced the maximal knee flexion and maximum internal and external rotation angle in the deficient knees. With the elastic support, the subjects demonstrated greater swing and stance phase flexion and greater external rotation than those without supports. These changes caused the kinematics of the involved limb to be more closely matched with those of the healthy limb and may indicate that this device is of proprioceptive benefit (e.g., pressure, warmth).

Knutzen *et al* (1987) carried out further work by adding a forceplate and repeated the test on the control limbs, ACL-deficient subjects without repair and ACL-deficient subjects with repair. Having measured the kinematic and force data, they confirmed their previous results (Knutzen *et al*, 1983) and found a decrease in maximum knee flexion angle and in total rotation in braced ACL-deficient subjects. They found interesting results regarding the force data that will be reviewed in the “force” section of this Chapter.

Knutzen *et al* (IN: Cawley, 1991) used a Cybex isokinetic dynamometer to measure the rotation of the tibia and torque patterns in normal and surgically repaired ACL-deficient

knees with and without a Lenox-Hill brace. Both maximum external and internal rotation of the surgical limb were less than those of the healthy, contra-lateral limb. Bracing the surgical limb reduced even further maximum external rotation, but increased maximum internal rotation of the tibia. With regards to torque (moments), similar results were found for torque production in the braced surgical limb, showing a decreased external rotation torque output and an increased internal torque output.

Petrone and Rood (1992) studied five arthroscopically proven ACL-deficient athletes and used six different functional knee braces to investigate the biomechanical changes occurring following knee bracing. The results of objective testing demonstrated that the braces did not result in a statistically significant reduction of tibiofemoral translation on arthrometric testing. Additionally, slower speeds and weaker Cybex testing performances were observed when the braces were worn. They concluded that, despite the subjective satisfactory results, no objective proof favoured of bracing.

Tegner and Lysholm (1985) evaluated some physiological changes following functional bracing to determine whether or not the braces provided additional stability to the patients with chronic ACL-deficiency. They used an off-the-shelf FKB in twenty-six patients with old ACL tears and unstable knees (positive pivot shift sign) and sixteen patients with reconstructed ACLs and stable knees (negative pivot shift sign). Isokinetics and isometric quadriceps strength were recorded bilaterally. The subjects were asked to run a figure-of-8 (both the straight run and the turns were timed), to perform a single-leg hop, to run up and down a spiral staircase and a 55 m slope. Testing was performed with and without the brace in randomised order. They reported no significant benefit of brace use and suggested that bracing should only be used adjunct to aggressive rehabilitation. This result is in contrast to that of Houston and Goemans (1991) who reported a correlation between brace wear and reduced leg extensor strength. The authors emphasised that muscle strengthening and rehabilitation are necessary to achieve successful function with a clinically unstable knee, and stressed that bracing should be a component of a patient's overall treatment regime.

Cawley et al (1991) criticised the Tegner and Lysholm's study and pointed out that the researchers have studied muscle performance and not mechanical knee stability of the evaluated patients. They claimed that it is probably a mistake to expect treatment of muscular deficits to be addressed by functional bracing. The bracing can only affect

abnormal translation or rotation, and a rehabilitative programme must manage muscular deficits.

Wojtys et al (1996) carried out a descriptive study of the EMG effects of the FKBs on the ACL-deficient knee and emphasised the major importance of muscle activation simultaneous with bracing. They measured the anterior-posterior translation with and without the stability contraction of the hamstrings, quadriceps, and the gastrocnemius muscles and found that the braces decreased the anterior-posterior tibial translation to 28.8% and 39.1% without the muscle contraction and to 69.8% and 84.9% when the lower extremity muscles were activated. They concluded that the lower limb muscle activation plays a major role, concomitant with bracing, in reducing the tibial translation in the ACL-deficient knees. This study is limited to the static position and it is not clear that braces could control the A-P tibial translation in dynamic situations particularly during sporting activities.

Bracing had no effect on any of the temporospatial parameters including maximum gait velocities, stride length, single and double limb support time or postural control reported by Gauffin et al (IN: Kramer, 1997). The above results of the temporospatial parameters in ACL-deficient subjects were analysed at five different velocities using switches on the shoes of the patients and employing a force platform. Similar results were reported by DeVita et al (1997) when a combination of the force platform and film data were used in both braced and non-braced ACL-reconstructed subjects. They concluded that bracing had no effect on movement patterns, ground reaction force, moment of force, and joint power curves in their study.

Since DeVita's study was carried out on the reconstructed knees, and not on deficient knees, the results are not applicable to ACL-deficient patients.

Acclimatisation to brace use is another issue highlighted in the literature. In a measurement analysis study between two types of FKBs in a group of 15 patients with ACL-deficient knee, Branch et al's (1988) patients wore one of following the braces; a deterioration strap model or a shell model with anterior tibial pad. The braces were used for an average of 24 months. Knees were positioned at 25° and 90° of flexion and both passive (6.8 and 9.1 Kg) and active (quadriceps contraction) loading were used. The braces significantly improved anterior drawer at 25° during passive loading. Bracing improved anterior displacement during active loading at 25° by 50% but could not

achieve normal limits. The investigators postulated that neither brace type would be effective against tibial translation during the higher loads expected during functional and athletic tasks.

In a study conducted by Liu et al (1994) the A-P tibial translation and the soft tissue compliance were studied in the low and high force activities. They evaluated the ability of orthoses for controlling tibial displacement. In this study, the effects of thigh soft tissue stiffness on the control of anterior tibial displacement were recorded on ACL-deficient surrogate knee models. They reported that at low forces (25N), soft tissue compliance did not play an important role in the reduction of anterior tibial displacement; however, at high forces (250 N) anterior tibial displacement was directly related to the soft tissue compliance.

Some researchers compared the custom moulded braces with the off-the-shell braces; or the strap-type braces with the shell-type braces. Contrary to Lubliner and Bash (1997), Vailas and Pink (1993) reported that the custom and the strap-type braces provided a better fit and more stability to the knee than the other braces. They also found that kinematic and force platform data suggested that the braces may produce some mechanical constraining effect to the entire lower extremity instead of just on the knee joint. They emphasised that FKB should be considered as a part of a comprehensive rehabilitation programme for an anterior cruciate-deficient athlete with significant functional deficits.

To provide a better understanding of the strain on the ACL in dynamic activity, the insertion of a specific measurement device into the ACL directed the investigators to obtain enhanced knowledge of the functions of the ACL during activity. Under local anaesthesia, Beynon et al (1992) arthroscopically implanted a Hall effect transducer to measure any displacement within small segments of the ACL while a known load was applied to the braced knee. Thirteen subjects who were candidates for arthroscopic knee diagnosis but had no knee ligament instability participated in the study. As an experimental protocol, four different loading activities including Lachman test (knees in 30 degrees of flexion), internal/external torque applied to the tibia in 30 degrees, active flexion/extension movement of the lower limb from 5-110 degrees and isometric contraction of the quadriceps with the knee flexed 30 degrees, were tested with and without a FKB. The results showed that only under low anterior shear loads, the braces

provided some protective strain-shielding effects. During active ROM of the knee from 10 to 120 degrees or during isometric contraction of the quadriceps, none of the braces produced adverse or hostile effects on the ACL. Interestingly, there was no advantage of the more expensive custom-made braces compared with the off-the-shelf designs. They emphasised the positive effects of two of the seven FKBs that provided a protective strain shielding effect on the ACL when anterior directed shear loads were applied to the knee in the non-weight bearing state. However, the strain shielding effect of the braces decreased as the magnitude of load increased. They stressed that some of the FKBs produced a protective strain shielding effect on the ACL for internal torque of the lower leg.

In another study, they (Beynnon *et al*, 1997) repeated the test and arthroscopically inserted a Differential Variable Reluctance Transducer (DVRT) into the ACL and the strain behaviour of the ACL was measured in the seated (non-weight bearing) and standing (weight bearing) position both with and without a brace. The results showed a significant increase in ligament strain values for the non-braced knee during movement from the seating to standing position (minimum shear and compression loads across the knee to the substantial shear force and compressive loads across the knee). The same results were reported when a 140-N anterior-directed load was applied to the tibia and the ACL-deficient knee subjects went from a seated position to a standing position. They concluded that bracing produced a protective effect on the ligament by significantly reducing the strain values for anterior-directed loading of the tibia up to 140 N and a good response to internal/external torque of the tibia up to 6 NM with the knee in a non-weight bearing state.

In a recent study, Beynnon *et al* (1999) invasively implanted a Differential Variable Reluctance Transducer (DVRT) into the intact ACL of four normal subjects. They aimed to determine if bracing produces a protective effect on the intact ACL strain with different anterior tibial tuberosity set up tensions (applied to produce a posterior directed load on the tibia that may reduce ACL strain). The test was carried out in both weight bearing and non-weight bearing positions. They found that in the non-weight bearing (seated position) and the standing position with the knees flexed at 30 degrees, the brace reduced ACL strain values for internal/external torque applied to the tibia up to 5 Nm. However, during the three test series on the braced and non-braced knee with anterior tibial strap tensioned in different force, there was no difference in ACL strain

values between the high and low anterior tibial tensions. They concluded that it might be due to the soft tissue compliance at the other regions of attachment of the brace to the lower limb.

In a very recent study, Fleming et al (2000) repeated the Beynnon's study (1997) on fifteen ACL-deficient subjects. They inserted a Differential Variable Reluctance Transducer (DVRT) into the anteromedial fibres of the ACL and measured the strain behaviour of the ACL in weight bearing (WB) and non-weight bearing (NWB) conditions. The applied weight equal to 40% of body weight as the compression loads to the joint. Anterior-posterior (A-P) shear loads, varus-valgus moments, and axial torques were applied to the leg both with and without the comprehensive load. In fact, they evaluated the ACL strain response in braced and non-braced knees during WB and NWB in combination with three externally applied loads. All external loads were applied to the tibia with the knee flexed to 20°. They reconfirmed their previous findings and reported that a FKB can protect the ACL during A-P shear loading in the NWB and WB knee and during internal torques in NWB knee.

Despite the results found in these types of studies, there are limitations in concluding whether a brace is effective in the ACL-deficient knee. Firstly, the transducer is inserted only in the one portion of the ACL, which may not be active in the extended knee and does not show the ACL strain during the standing from sitting position (weight bearing position). Secondly, it is a relatively static test rather than a dynamic active test, and does not show the ACL strain during most daily activities. Thirdly, all of these studies have been carried out in normal knees with an intact ACL and therefore, using a brace may demonstrate no protective effect on a healthy knee as the physiological protective agents such as ACL, PCL, collateral ligaments and capsules are intact. Finally, they can only show the instantaneous protection effects of a FKB and cannot test the long-term changes that wearing a FKB may produce in the knee joint muscles.

Another invasive method is the use of an X-ray technique on the subjects in an *in vivo* activity. Jonsson and Karrholm (1990) directly studied the effects of all three brace types (prophylactic, rehabilitative, and functional) in controlling A-P and rotatory instability. Using the Roentgen radiographic method, they evaluated each of the three brace types on seven limbs. Patients lay supine whilst braced and non-braced knee alignment was recorded in positions of full extension, 30 degrees of flexion with anterior or posterior

traction, and 20 degrees of flexion with external or internal rotation applied, alone or in combination with anterior traction. Application of the rehabilitative brace not effective on controlling the A-P position of the tibia, whereas application of the prophylactic brace was associated with an increased internal tibial rotation. The non-braced knee A-P instability was significantly greater than that of normal knees and application of either the rehabilitative or functional brace significantly reduced A-P laxity but not to normal levels. Internal and external rotations without anterior traction were not significantly different in the uninvolved and non-braced involved knees. Application of the functional brace significantly reduced external rotation. No braces affected internal tibial rotation. For both uninvolved and non-braced involved limbs, external rotation decreased significantly when anterior traction was applied, and internal rotation increased significantly. The involved limb demonstrated greater reduction in external rotation than the uninvolved limb. None of the braces could significantly control the external or internal rotation during anterior traction.

It is concluded that the use of FKBs in the rehabilitation of a knee with a partially torn ACL, an unstable knee with a completely disrupted ACL, or a knee with a healing ACL graft has gained acceptance by sports medicine physicians (Beynnon *et al*, 1997; Beynnon *et al*, 1992; Coughlin *et al*, 1999; Millet *et al*, IN: Beynnon *et al*, 1999). However, Styf (1999) warned of some disadvantages of using any external compressions and emphasised that all external compression tools may abnormally elevate intramuscular pressure beneath the straps of the knee brace, decrease local muscle blood flow and muscular oxygenation and induce premature muscle fatigue. Styf (1999) warned athletes and coaches of the serious adverse effects of knee bracing.

Side-step cutting manoeuvres and running are two vigorous exercises in which tests have been carried out, with and without FKBs. Investigators have studied the effects of FKBs on running manoeuvres and have assessed some changes in the biomechanics of the knee joint following bracing. Branch *et al* (1993) studied the kinematic changes using two different types of FKBs (shell and strap types) which are used by the ACL-deficient knee athletes. The test was set using a side-step cutting manoeuvre and a 3-D motion analysis tracking system was used for recording the kinematic changes of subjects while they performed a 90 degrees side-step cut. No statistical differences were reported when the results were compared with isolated joint rotation. No increased knee or hip flexion was recorded during the manoeuvre.

Compensatory early turning of the body towards the cut caused an increase cumulative external rotation of the hip, knee and ankle joints. They concluded that total rotation of the planted limb in the strap-type brace was close to the normal subjects' pattern, while those in the shell-type brace were close to the pattern of ACL-deficient knee subjects. They also emphasised there were problems relating to the passive reflexive markers and the failure of the multiple 60 HZ camera to adequately track many runs. Furthermore, the un-shuttered 60 HZ cameras, which led to trials on the tracking images, the swing phase was not analysed and only the stance phase of the manoeuvre could be analysed.

Tables 2-3 and 2-4 show a summary of the studies regarding the effects of FKBs and the EMG studies following knee bracing on the ACL-deficient knees.

Table 2-3 Summary Studies of the Effects of FKBs in ACL-Deficient Knee.

Researcher (s)	Year	Study	Instrumentation	Results
AAOS <i>et al.</i>	1984	Knee Brace Seminar	Seminar Presentation	A controversy exists regarding the effectiveness of knee bracing and further research is recommended.
Cawley <i>et al.</i>	1991	Criticising the current state of knowledge about knee bracing.	Literature Review	Most of the previous studies in this area should be repeated using optic/optoelectronic devices
Wojtys <i>et al.</i>	1987	Evaluation of Lenox Hill brace	In vitro	This brace might be effective in reducing anterior tibial translation
Houston and Goemans	1982	The effects of a brace in ACL-deficient and ACL-reconstructed knee.	Cybox Dynamometer	-There is a correlation between leg extensor strength with brace. -Bracing is an essential part of a patient's overall treatment.
Knutzen <i>et al.</i>	1983	To determine the effects of FKBs on ACL-repaired knees during overground running.	Electrogoniometer	-Derotation braces significantly reduced maximal knee flexion and rotations in swing. - With elastic support, the ACL-def. side showed greater knee flexion and external rotation.
Knutzen <i>et al.</i>	1984	Measurement of tibial rotational and torque pattern in normal and ACL-reconstructed knee with and without a Lenox-Hill brace	Cybox isokinetic dynamometer	-Both internal/external tibial rotations were less in ACL-reconstructed knees than normal knees without brace. -ACL-reconstruction knee showed decreased external rotation torque but increased internal rotation torque. -Bracing further reduced maximum external rotation but increased maximum internal rotation torque.

Table 2-3 Summary of the Studies of the Effects of FKBs in ACL-Deficient Knee – cont.

Researcher (s)	Year	Study	Instrumentation	Results
Tegner and Lysholm	1985	The effects of a FKB in ACL-deficient and ACL-reconstruction knee during figure-of-8 running.	Cybox Dynamometer	No significant benefit of brace use was found and it was suggested that it be used as part of aggressive rehabilitation.
Beck <i>et al.</i>	1986	Determining of the effects of two types of braces on ACL-def. knee (<i>in vivo</i>).	Arthrometer	-The hinge, post, shell type was better than the hinge, post, strap type brace. -The both braces were only effective at controlling ant. tibia at low loads (89N) and not higher load.
Colville <i>et al.</i>	1986	Evaluation of a Lenox Hill FKB (<i>in vivo</i>)	Arthrometer	The brace controlled the A-P displacement of tibia in low loads (100N), but was not affective at maximum anterior drawer force.
Knutzen <i>et al.</i>	1987	To determine the effects of FKBs on ACL-def, knee during overground running.	Electrogoniometer and Forceplate	-They reconfirmed their results (1983) that brace increased knee flexion and total rotation. -Increased peak braking force was found in braced ACL-deficient knees.
White <i>et al.</i>	1988	The effects of FKBs on the lower limb joint kinematics	Electrogoniometer	-No kinematics changes occurred in the lower limb joints following FKB. -Increased peak braking force occurred following FKB. -Hip kinematics changed as a result of knee bracing.

Table 2-3 Summary of the Studies of the Effects of FKBs in ACL-Deficient Knee – cont.

Researcher (s)	Year	Study	Instrumentation	Results
Czerniec-ki <i>et al.</i>	1988	Measurement of tibial rotation in ACL-def. Knees.	Electrogoniometer	No different was found in terms of knee rotation.
Branch <i>et al.</i>	1988	The effects of a derotation strap model FKB on ACL-def. subjects during passive and active loading.	Arthrometer	-Both braces significantly reduced the A-P displacement in static low loads. -None of the braces tested would be effective during higher load activities.
Rink <i>et al.</i>	1989	Evaluation of a Lenox Hill FKB (<i>in vivo</i>)	Arthrometer	The brace controlled the A-P displacement of tibia in low load (89N) only.
Beynnon <i>et al.</i>	1989	The effects of bracing in ACL strain.	Inserting HEST in the normal ACL	During static shear loading, bracing had no effect on <i>in vivo</i> ACL strain.
Wojtys <i>et al.</i>	1990	Evaluation of 14 braces in six cadaveric knees (<i>in vitro</i>).	Arthrometer	None of them significantly reduced AP displacement in the knees.
Bach <i>et al.</i>	1990	Examination of the extent of A-P displacement with the time from injury.	Arthrometer	No relationship was found between the extent of AP displacement and the time from injury.
Jonsson and Karrholm	1990	The effects of FKBs on ACL-def. knees (using an invasive method)	Roentgenographic technique	-Both rehabilitative and functional braces reduced AP laxity, but not to normal level. -None of the braces had any effect on internal rotation, but FKB reduced external rotation.
Knutzen <i>et al.</i>	1991	Kinetic analysis of FKB	Electrogoniometer	FKB increased GRF during walking
Wojtys <i>et al.</i>	1991	Biomechanical evaluation of a Lenox Hill brace (<i>in vitro</i>)	Arthrometer	The Lenox Hill brace may be helpful for ACL-deficient knees if the medial collateral ligaments are intact.
Hirokawa and Bagger	1992	The effects of muscle activation together with a DonJoy FKB.	Computerised electrogoniometer	Hamstring activity, as opposed to the quadriceps activity, could significantly reduce the AP displacement.

Table 2-3 Summary of the Studies of the Effects of FKBs in ACL-Deficient Knee – cont.

Researcher (s)	Year	Study	Instrumentation	Results
Beynnon <i>et al.</i>	1992	The effects of braces on ACL strain (direct measurement of the strain in the ACL)	Implanting a Hall Effect Transducer into the intact ACL.	-Braces proved to be protective only under low anterior shear forces. -None of the braces produced adverse or hostile effects during isometric contraction of the quadriceps muscles and the expensive custom-made braces had no advantages over the off-the-shelf designs.
Petrone and Rood	1992	The effects of a FKB in AP displacement	Arthrometer and Cybex Dynamometer	Despite the subjective satisfactory results, no objective results were found.
Villas <i>et al.</i>	1993	The effects of bracing on the biomechanics of the lower limb joints	Force platform and gait analysis system	-Custom-made and strap-type braces provided a better fit and stability for the knee. -Bracing may change the entire lower limb instead of just the knee joint.
Branch <i>et al.</i>	1993	Kinematic changes following two types FKBs during side-step cutting manoeuvre.	3D motion analysis tracking system (60Hz).	No kinematic changes occurred on the lower limb joints following FKBs.
Liu <i>et al.</i>	1995	The effects of a FKB in A-P displacement in a surrogate knee model.	A force gauge, displacement scale	The orthoses were effective at high load (250 N), but not at low load (25N) at reducing the AP displacement of the tibia.
Wojtys <i>et al.</i>	1996	The role of muscle activity simultaneous with FKBs.	EMG and Arthrometer	The lower limb muscles play a major role, concomitant with bracing, in reducing the tibia translation in ACL-def. subjects.
DeVita <i>et al.</i>	1997	Measurement of biomechanical parameters in ACL-def. knee with and without FKBs.	Force platform and film data	No effects of bracing were found on maximum gait velocity, stride length and single and double limb support.
Gauffin <i>et al.</i>	1997	Measurement of biomechanical parameters in ACL-def. knee with and without FKBs.	Force platform and foot switches in different velocities	No effects of bracing were found on maximum gait velocity, stride length and single and double limb support.

Table 2-3 Summary of the Studies of the Effects of FKBs in ACL-Deficient Knee – cont.

Researcher (s)	Year	Study	Instrumentation	Results
Beynnon <i>et al.</i>	1997 and 1999	The effects of bracing on the biomechanics of the lower limb joints during NWB and WB conditions	Implanting a DVRT transducer into the intact ACL.	Bracing produced a protection effect on the ligament during changing from NWB to WB position and anterior-directed loading of the tibia (140 N)
Styf	1999	Disadvantages of wearing any external compression appliances.	Physiological tests	All external compression may abnormally increase intra-muscular pressure beneath the straps.
Fleming <i>et al.</i>	2000	The effects of bracing on the biomechanics of the lower limb joints during NWB and WB conditions	Implanting a DVRT transducer into the intact ACL	-FKBs can protect the ACL during A-P shear loading in the NWB and WB knee. -FKBs can protect the ACL during internal torques only in the NWB knee.

Table 2-4 Summaries of The EMG Studies Following Bracing in ACL-Deficient Subjects.

Researcher (s)	Year	Study	Instrumentation	Result
Branch <i>et al.</i>	1989	EMG following Lenox Hill and CTi braces in side-step cutting manoeuvre	EMG	Bracing did not alter EMG firing patterns compared to the non-braced condition.
Lass <i>et al.</i>	1991	EMG in ACL-deficiency in treadmill running	EMG	Altered gastrocnemius and thigh muscle activity is an attempt to stabilise knee joint
Acierno <i>et al.</i>	1995	Determine the effects of a symptom (e.g. pain and swelling) on the EMG parameters in ACL-def. knee with and without a brace.	EMG and Kincom Isokinetic System	The presence of symptoms is a determinant factor causing increased quadriceps and decreased hamstring activities in symptomatic ACL-deficient knees.
Beard <i>et al.</i>	1996	EMG analysis of normal and ACL-deficient Knee	EMG and VICON	The "net increase in internal flexion moment" can be due to increased hamstrings and not decreased quadriceps activity
Nemeth <i>et al.</i>	1997	Bracing and Proprioception	EMG	Increased afferent input from proprioceptors following knee bracing.

2.6. Kinetic Analysis Following FKBs on the ACL-Deficient Knee

Joint moments of force (JMF) reveal insight to the neuromotor patterns producing the movement (Winter, 1987). Elftman (Elftman IN: Andriacchi, 1990) was a pioneering researcher who used the combination of film and ground reaction force data to determine the kinetics of the lower extremity during gait. Bressler and Frankel (IN: Andriacchi 1990) developed equations to account for the inertial effects and weight of the individual segments and also devised the basic link segment model. This model was expressed as a free body diagram and required knowledge of the ground reaction force and kinematic data allowed the researcher to calculate the kinetics at each segment end according to Newton's laws (Winter, 1979). The model output includes joint reaction forces and net joint moments of force at the ankle, knee and hip. The model calculation used in kinetics includes a mathematical model, which appropriately identifies the anthropometric characteristics of each individual body segment. The ground reaction force (GRF) is the reaction of the ground, relative to the forces applied to it through body weight, as body moves across the supporting foot. Vertical, horizontal and rotatory forces are three vectors generated on the floor that can be measured with appropriate instrumentation. The GRF is equal in intensity and opposite in direction to those experienced by the weight-bearing limb. A force platform is the usual instrumentation used to measure the ground reaction forces in all three directions. An analogue-digital converter is used to collect the force data, which is fed into a computer. In gait analysis studies, GRF data is usually used with other gait analysis data such as kinematics, EMG, etc. However, it is valuable in some studies in addition to its necessity for calculating joint moments and power.

The ground reaction forces have three-dimensions: the vertical (impact force), antero-posterior (fore-aft) shear force and the medio-lateral shear force. The full kinematic description can be obtained from different types of cameras and scanners including high-speed film analysis systems.

Some researchers have studied the kinetic data to calculate the effects of bracing on the ACL-deficient subjects. During the impact phase of walking on level ground, an increased ground reaction force (GRF) was reported by Knutzen et al (1991) in braced ACL-deficient subjects. However, DeVita et al (1997) used a combination of the force platform and film data on the ACL-reconstructed knee subjects and reported that bracing

had no effect on movement patterns, ground reaction force, moment of force or joint power curves.

DeVita et al (1992) comprehensively studied the biomechanical changes after wearing a FKB by ACL-reconstructed knee subjects during over-ground running. They assessed the joint moments of force, joint power, and ground reaction force as well as joint positions in the lower extremity during the stance phase of running in subjects with an ACL-reconstructed knee. A sagittal plane film and a force platform were used to obtain data from the healthy and ACL-deficient knee patients with and without a FKB. An inverse dynamic analysis combining anthropometric, kinematic and ground reaction force was used to calculate the joint moments of force for the lower extremity throughout the stride. The results revealed that the joint position curves, ground reaction force, moment of force and joint power curves were similar between the two groups. However, the extensor angular impulse in the ACL-deficient knee subjects in the non-braced condition at the hip joint was 59% larger than that in either braced patients or healthy runners. The impulse values at the ankle joint were 36% larger for the non-braced ACL subjects compared with the braced ACL subjects and 27% larger when compared to the healthy runners. Alternatively, the healthy runners had 241% and 227% large impulse values at the knee joint compared with the ACL non-braced and braced conditions respectively. They concluded that reduction of the extensor moment of force about the knee joint and increase in the moments of force about the hip and ankle joints in the previously injured subjects reduced the stresses on the reconstructed ACL and tibia while also enabling them to run at the required speed.

In the studies evaluating the effects of orthoses on ACL-deficient knees, it appears that functional testing of knee brace efficacy is being more commonly performed. This is because equipment to measure ground reaction forces and joint motion has become more accessible in the clinical laboratory.

The changes of force value in ACL-deficient knee have been studied in some literature. Kiefer et al (1985) studied the effects of ACL-deficiency on the force value during walking and running on the ground. They reported that at heel contact, the ACL-deficient limb exhibited increased maximal lateral reaction forces and during stance phase, decreased maximal lateral forces. During toe-off, the maximal knee moment of rotation is greater than normal for the ACL-deficient limb in walking alone. They

concluded that, as the frequency of the force signal increases the loading of the ACL-deficient limb decreases. When the muscle active control of movement exists, the voluntary load reduction was the most effective during stance and toe-off phases. However, during heel contact when passive forces predominate, voluntary load reduction is less effective.

In 1987, Knutzen et al (1987) tested seven ACL injured, seven ACL reconstructed and seven control individuals and evaluated the effects of two functional knee braces during level ground running at a control speed and measured the GRFs and 3-D knee motion. In terms of ground reaction force, significant changes resulting from brace wear were noted primarily in the impact phase of the support period. The timing, magnitude, and impulse measures for the initial vertical force peak and the braking force increased following bracing. The researchers' attention to ground reaction forces indicates their understanding that it is important not only to evaluate knee parameters but to recognise that changes imposed on the knee by bracing affect other joints and limb segments in the kinetic chain. The testing in this study could be expanded to assess more specifically changes in lower limb joint moments caused by brace use.

In another study, a significantly less medio-lateral force value was reported in ACL-deficient subjects between 35 to 55% of stance phase (Hassan *et al.*, 1991). However, during standard pivoting, the vertical forces between 24 to 29% and between 47 to 70% of stance were significantly greater in the injured population. Finally, they found that during cross-pivoting, the vertical force between 29 to 32% and 85 to 95% of stance was less in the injured subjects.

Cook (IN: Beynnon *et al.*, 1999) asked 14 ACL-deficient knee subjects to wear a shell type brace for at least 6 months to become accustomed to using a brace. The tasks included running and cutting with and without bracing and the high-speed video and force platform data were collected. All three components of the GRF (vertical, sagittal, and coronal) vectors increased in braced ACL-deficient subjects in a straight cut using the involved limb. In a cross cut, vertical and sagittal forces increased with bracing. In both cut styles, when the involved limb was braced, the sound limb demonstrated increased sagittal forces. No difference in GRFs for either limb was noted in straight running unless the population was subgrouped based on muscle strength scores. Those subjects who had not achieved 80% of their uninjured quadriceps strength on their involved side demonstrated increased straight running velocity with brace use. Both

muscle strength subgroups (>80% and <80%), when analysed separately, demonstrated reduced aft and lateral shear on the braced involved limb during straight running and reduced aft shear on the sound limb when the involved limb was braced. Although this is a good study in force data, it should be noted that subgrouping reduces the sample size (in this study from 14 to 5 and 9) and consequently affects on the reliability of the reported *p* value (0.1).

Ramsey et al (2001) in an *in vivo* dynamic study analysed the kinematics and force of five ACL-deficient subjects. They inserted intra-cortical pins into the tibia and femur and tested them in a jumping task. They reported a non-significant increase in the impact force of the braced knee and concluded that bracing may forward the ACL-deficient patients in a dangerous position by increasing force on the deficient knee.

Changing the functional ability of ACL-deficient patients years after past injury have been frequently reported in the literature. Berchuck et al (1990) noticed that different adaptations occur in ACL-deficient knees during slow and fast movements.

Andriacchi (1990) studied ACL-deficient subjects and deliberately evaluated the adaptations occurring in ACL-deficient patients during different type activities. Using a video-based gait analysis system and a force platform, the kinematic and kinetic measurements of the common functional characteristics of ACL-deficient subjects were studied in addition to their adaptations to the deficiency during stressful activities. During level walking, the primary characteristic was a tendency to avoid or reduce the net quadriceps moment at the knee. The author reported that approximately 75% of the ACL-deficient subjects developed this type of adaptation. This tendency to avoid the net quadriceps moment was considered to be related to the angle of knee flexion and ultimately to the anterior pull of the extensor mechanism of the knee when the knee is near full extension. He found that avoiding the net quadriceps moment was associated with an increase in the moment sustained by the hamstring, during the early phase of these activities. He suggested that ACL-deficient subjects may use more hamstring activity to provide muscular substitution for the absent ACL during more stressful activities. The author described that, when subjects modify their functions, the strains in the secondary restraints to anterior drawer of the knee are substantially reduced. The nature of the adaptation also suggests that there is a dynamic reprogramming of the locomotor system in some subjects whilst not in others.

In another study, Berchuck et al (1990) studied the changes in function of the ACL-deficient knee whilst walking, jogging and ascending and descending stairs. Kinematic and kinetic findings for the right and left hip/knee/ankle joints of 16 ACL-deficient knees and ten normal subjects were recorded during each activity. The instrumentation consisted of a two-camera optoelectronic digitizer, light emitting diodes (LEDs) and a force platform to measure the kinematics and kinetics of the subjects, respectively.

The results confirmed a "quadriceps avoidance gait (QAG) pattern" in 75% of ACL-deficient knee patients in which no net quadriceps (extension) moment was necessary during midstance. They also emphasised that this pattern of gait was related to the angle of flexion of the knee when the maximum flexion moment occurred during each activity. They postulated that this correlation between the gait pattern and the knee flexion angle meant that the patients changed their gait to avoid the anterior displacement of the proximal end of the tibia which is normally produced when the quadriceps contract while the knee is in nearly full extension. The results of the study showed that walking produced the largest percentage change from normal in the external flexion moment at the knee and jogging and stair-climbing produced the less changes. They reported that the most strain on the ACL occurred when the knee was in full extension in walking, rather than knee flexion in jogging or during stair climbing. Consequently in jogging and stair climbing, the adaptations diminish and the ACL suffers more pressure than in walking. The quadriceps muscles have been shown to reduce strain in the ACL beyond 60 degrees of knee flexion.

The remaining 25% of patients who did not show the QAG pattern in Berchuck's study had the normal bi-phasic pattern of moments. They found that the largest changes occurred during level walking rather than during other strenuous activities and this is due to a marked strain on the ACL when the knee is less than 60 degrees. They concluded that even in patients who had asymptomatic ACL-deficiency, the mechanics of the knee joint were greatly altered by adaptive changes in patterns of gait in low stress activity such as walking. The functional changes in walking can be expected to modify the overall pattern of loading on ACL-deficient knees and therefore, cause abnormal loading on specific structures of these knees. Such factors may influence the long-term changes that are found in cruciate-deficient knees (Berchuck *et al*, 1990).

Andriacchi and Birac (1993) repeated the above study with some more activities such as lateral side-step cut, run-to-stop manoeuvre and some common daily activities such as walking, stair climbing, and jogging. Again, they confirmed the “quadriceps avoidance gait” in approximately 75% of the subjects indicating a subconscious avoiding of the quadriceps when the knee was near full extension (Fig. 2-2).

According to Berchuck (1990), 75% of the ACL-deficient subjects unintentionally change their gait pattern to avoid an anterior displacement of the proximal end of the tibia that is normally produced when the quadriceps contracts while the knee is in nearly full extension. This type of gait which represents a “protective mechanism” to avoid the pivoting phenomenon in ACL-insufficiency was called “Quadriceps Avoidance Gait” Pattern. This pattern of gait in the ACL-deficient subjects has not yet been confirmed and still is a controversial issue.

To discover if time following injury affects occurrence of the QAG pattern in ACL-deficient subjects, Wexler et al (1998) categorised the ACL-deficient knee patients into three groups: early (0-2.5 years), intermediate (2.5-7.5 years) and chronic groups (greater than 7.5 years); and compared them with the same number of healthy subjects. A two-camera optoelectronic digitiser and a multi-component force platform were used to measure the kinematics and kinetics of the affected and normal lower extremities. The geometric centres, external moments and 3-D components of each hip/knee/ankle joints were calculated. They showed that the ACL-deficient knee group had a significantly decreased midstance knee flexion moment compared with the midstance knee flexion moment of the control group. A significant linear relationship existed between the early midstance knee moment and its corresponding angle of knee flexion. The ACL-deficient knee patients also had a greater knee flexion angle when generating a comparable midstance knee flexion moments as compared to the control subjects. They concluded that the ACL-deficient knee patients adapted to their injury over time and the changes in the moments were interpreted to represent a net reduction or avoidance in quadriceps use and an emphasis on hamstring use. Thus, a new phasing between the knee flexors and extensors in which the use of the quadriceps is reduced and the use of the knee flexors is increased, was assumed over time.

2.6.1 Quadriceps Avoidance

Gait (QAG) Pattern in Detail

As mentioned earlier, the quadriceps avoidance gait (Figure 2-2) is defined as a net reduction or avoidance in quadriceps use and an emphasis is on the hamstring use (Andriacchi, 1990; Wexler *et al*, 1998). The occurrence of this phenomenon was questioned by some authors and still is a controversial issue.

Figure 2-2. Quadriceps Avoidance Gait Phenomenon

[From: Berchuck,M; Andriacchi,TP.; Bach,BR.; et al. Gait adaptations by patients who have a deficient anterior cruciate ligament. *The J. of Bone and Joint Surgery (Am.)* 72(6), 1990, 871-877.

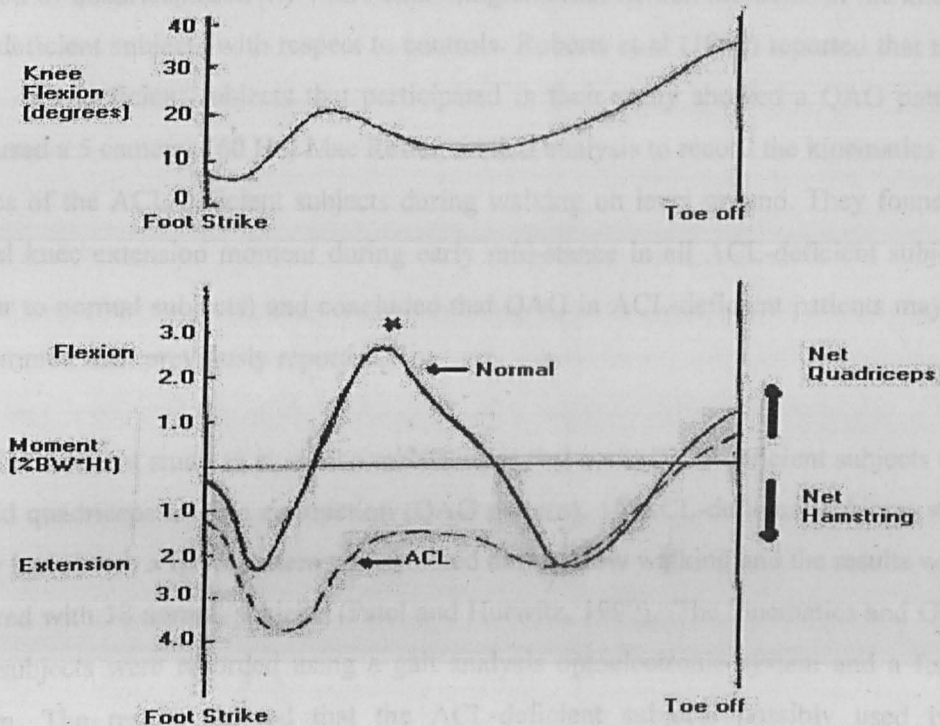

Berchuk *et al* (1990) popularised the concept of quadriceps-avoidance an external extension moment at the knee in stance, in the ACL-deficient patients as an attempt to decrease anterior shear forces on the tibia. They emphasised that this pattern of gait was related to the angle of flexion of the knee when the maximum flexion moment occurs during each activity. They postulated that this correlation between the gait pattern and the knee flexion angle meant that the patients changed their gait to avoid the anterior displacement of the proximal end of the tibia that is normally produced when the quadriceps contracts and the knee is in nearly full extension. However, some investigators have reported that they were unable to reproduce the phenomenon of QAG. Kadaba (IN: Roberts *et al*, 1999) reported a flexed knee pattern combined with external

knee flexion moments rather than a quadriceps avoidance pattern in unreconstructed ACL-deficient patients. Even patients in the post-operative period after ACL reconstruction with a patellar tendon autograft from the extensor mechanism, where it would be expected that quadriceps avoidance would be easily observable, have not demonstrated this adaptation (Timoney *et al*, 1993). Snyder-Mackler and Delitto (1999) reported kinematic alterations consistent with a co-contraction strategy of the quadriceps and hamstrings in the early postoperative phase after ACL reconstruction.

Beard *et al* (1996) reported an increase in the duration of hamstring activity with similar duration of quadriceps activity while exhibiting external flexion moments at the knee in ACL-deficient subjects with respect to controls. Roberts *et al* (1999) reported that none of the ACL-deficient subjects that participated in their study showed a QAG pattern. They used a 5 cameras (60 Hz) Mac Reflex motion analysis to record the kinematics and kinetics of the ACL-deficient subjects during walking on level ground. They found an internal knee extension moment during early mid-stance in all ACL-deficient subjects (similar to normal subjects) and concluded that QAG in ACL-deficient patients may be less common than previously reported.

In a recent study to study the mechanisms that some ACL-deficient subjects use to avoid quadriceps muscle contraction (QAG pattern), 18 ACL-deficient subjects who already had shown a QAG pattern were studied during slow walking and the results were compared with 18 normal subjects (Patel and Hurwitz, 1999). The kinematics and GRF of the subjects were recorded using a gait analysis optoelectronic system and a force platform. The results showed that the ACL-deficient subjects possibly used two mechanisms for a QAG, including reduction of the midstance knee flexion angle (in 72% of the subjects) and an increased peak external hip flexor moment in the rest of subjects. Indeed, by reducing knee flexion during midstance the patients reduced the demand for the quadriceps and this consequently minimised the anterior pull of the tibia, therefore helping the knee to maintain stability. The second mechanism was found in 28% of the remainder of the patients who did not show a decreased midstance knee flexion angle. They increased their external hip flexion moment during mid stance as compared to the normal group. Indeed, by leaning forward during mid stance, they increased the hip flexion moment and consequently reduced the demand on the quadriceps muscles. Since the majority of the hip extensors cross both the hip and knee joints, extending the hip joint has a tendency to flex the knee throughout mid stance (Patel and Hurwitz, 1999).

To evaluate whether the QAG pattern is confirmed by EMG activities as well as knee moments, Ciccotti et al (1994) studied the EMG parameters in three normal, rehabilitated ACL-deficient and reconstructed ACL-deficient groups. Using fine-wire EMG apparatus, they evaluated the muscles around the knee joint during various activities. The activities included free walking on level ground (1.5 m/s), ramp ascending and descending at 1.5 m/sec on a 10 % gradient, stair ascending and descending at 1.5 m/sec on a three step platform, running in a straight line at 6 m/s, and cross-cutting straight running at 6 m/s. The EMG graph of each activity was plotted. During early stance phase of the running on the ground, decreased activities of the vastus medialis oblique and the vastus lateralis muscles in both the rehabilitated and reconstructed groups were shown. They concluded that this might represent a QAG as described by Berchuck et al (1990).

In Berchuck's study (1990), the Vastus lateralis, biceps femoris and tibial anterior muscle activity led to diminished internal tibial rotation and, such movement represents a "protective mechanism" to avoid the pivoting phenomenon with ACL-insufficiency. The biceps femoris in the rehabilitated ACL-deficient knee subjects showed that it acts not only to prevent anterior tibial translation but also to protect the knee from the pivoting phenomenon that may occur.

Similarly, in an EMG study Solomonow et al (1987) investigated the EGM pattern of 12 ACL-deficient knee patients and found a surge of hamstring EMG activity and a concurrent drop in quadriceps activity while producing a maximum knee extension effort on the Cybex machine. The sudden drop in quadriceps torque and firing activity was measured in 42 degrees from full extension. It was concomitant with the hamstring activity, which showed a reflexive attempt of the hamstring to stabilise the dynamic anterior tibial subluxation during an explosive knee extension manoeuvre.

Significant differences were found in the muscle synergy patterns during walking in a study conducted by Limbird et al (1988). They studied twelve subjects with ACL-deficiency and 15 normal subjects as the control group. The subjects carried out a walk at free and fast speeds on a twelve-meter walkway. The right and the left foot contact patterns and the linear envelopes from the EMG patterns of the quadriceps, hamstring and the gastrocnemius muscles were measured. During the swing-to-stance transition, all

subjects showed significantly less activity in the quadriceps and gastrocnemius muscles and more activity in the biceps femoris than in the normal group. They found that during early swing, the vastus lateralis is more active in ACL-deficient knees than that of the normal subjects. These dynamic compensatory mechanisms suggest that use of the hamstring tendons in reconstructive procedure may alter important compensatory mechanisms surrounding the knee joint.

As a result, the QAG pattern reported in some studies, has indicated that some ACL-deficient patients do not use their quadriceps muscles in most part of stance (Berchuck *et al* 1990). However, other investigators have reported opposite results and claimed that none of their patients exhibited this phenomenon (Roberts *et al*, 1999). Others claimed that the increased net flexion moment can be due to the increased hamstring activity rather than the decreased quadriceps activity (Beard *et al*, 1996). EMG signals have shown different results in various studies and have yet not confirmed this phenomenon. This controversial issue is of importance in rehabilitation programmes for ACL-deficient knees. There is no clear consensus about the moments and power alteration following bracing or taping in the ACL-deficient knees.

Table 2-5 Summary of the Ground Reaction Force Studies in ACL-Deficient Knees.

Researcher(s)	Year	Study	Instrumentation	Result
Knutzen <i>et al.</i>	1983	To determine the effects of FKB on force value	Force platform	An increased GRF during impact phase of walking in braced ACL-deficient knees was reported.
Kiefer <i>et al.</i>	1985	To determine the effects of FKB on force value during overground running.	Force Platform	-At heel strike, the maximum lateral reaction forces increased in the ACL-deficient subjects. -In stance phase, they showed decreased maximum lateral reaction forces.
Knutzen <i>et al.</i>	1987	To determine the effects of FKB on ACL-def. knees during overground running.	Electrogoniometer and Forceplate	Increased initial vertical and braking forces were noted in braced ACL-deficient subjects.
White <i>et al.</i>	1988	To determine the effects of FKB in the normal knee.	Force Platform	An increased peak braking force in the braced knee was found.
Cook <i>et al.</i>	1989	To determine the effects of FKB on force value during running and cutting with and without brace.	High-speed video cameras and forceplate	-In straight cut, all three GRF components increased. -In crosscut, the vertical and sagittal GRF components increased.
Hassan <i>et al.</i>	1991	To determine the effects of FKB on ACL-def. knees during walking, standard pivoting, and cross pivoting.	Forceplate	-Braced ACL-deficient subjects showed less medio-lateral forces. -In standard pivoting, the vertical forces increased in braced ACL-deficient subjects. -During cross pivoting, the vertical force was less in the ACL-deficient subjects.
DeVita <i>et al.</i>	1992 and 1997	To determine the effects of FKB on the biomechanical factors during running overground.	Forceplate and film data (video recording)	Bracing had no effect on movement patterns, GRF, moments and joint power.

Table 2-6 Summary of the Studies Regarding QAG and Proprioception in ACL-Deficient Knees.

Researcher(s)	Year	Study	Instrumentation	Results
Berchuck <i>et al.</i>	1990	EMG and kinetics in jogging and stair walking in ACL-deficient knees.	EMG and two-cameras and force plate	QAG was confirmed in 75% of the ACL-deficient knee subjects.
Andriacchi <i>et al.</i>	1990	Gait adaptation in ACL-deficient subjects in a side-step cutting manoeuvre.	EMG and motion analysis system	ACL-def. subjects had more hip and knee flexion, which probably holds the hamstring in a better position to stabilise the tibia more efficiently and to prevent abnormal anterior tibial translation and internal/external rotation.
Corrigan <i>et al.</i>	1992	Proprioception after ACL-deficiency.	A proprioception test device	A significant decrease in position sense in ACL-deficient knee subjects.
Andriacchi <i>et al.</i>	1993	EMG and kinetics in run-to-stop manoeuvre and some common activities	EMG and two-camera and force plate	Again QAG in 75% of the subjects was confirmed
Kadaba <i>et al.</i>	1993	Gait adaptation in ACL-deficient subjects	EMG and motion analysis system	No QAG was reported in ACL-def. subjects. A flexed knee pattern combined with external knee flexion moments was reported.
Timoney <i>et al.</i>	1993	Gait adaptation in ACL-reconstructed knees with patellar tendon.	EMG and motion analysis system	Despite the researchers' expectations, they did not demonstrate any QAG pattern.
Wojtys <i>et al.</i>	1994	Measurement of MRT (muscle reaction time).	EMG	Slower MRT in the ACL-deficient subjects
Ciccotti <i>et al.</i>	1994	EMG study of the normal, rehabilitated ACL-def. and ACL-reconstructed knee during running on the ground.	EMG	A decreased vastus medialis oblique and vastus lateralis muscle activation reported in both rehabilitated and reconstructed knees during early stance phase of running on the ground which may represent a QAG pattern as explained by Berchuck <i>et al.</i>
Snyder-Mackler <i>et al.</i>	1995	Gait adaptation in ACL-reconstructed knees	EMG and motion analysis system	Some kinematic alterations consistent with co-contraction strategy of the quadriceps and hamstring in early post-operative phase were reported.

Table 2-6 Summary of the Studies Regarding QAG and Proprioception on ACL-Deficient Knee – cont.

Researcher(s)	Year	Study	Instrumentation	Results
Beard <i>et al.</i>	1996	Gait adaptation in ACL-reconstructed knees	EMG and motion analysis system	An increased duration in quadriceps and hamstring and external flexion moments in ACL-deficient subjects was reported.
Borsa <i>et al.</i>	1997	Proprioception after ACL-deficiency.	A proprioception test device	Decreased proprioception in ACL-deficient knee subjects, worsened in the end range
Beynon <i>et al.</i>	1999	Effect of a FKB and a neoprene sleeve on proprioception.	Arthrometer and Proprioceptive test device	No significant difference was found between changing the threshold to detect a passive motion, in comparison with the same knee without a brace, although improvements were observed.
Pap <i>et al.</i>	1999	Differences in proprioception between normal and ACL-def. subjects.	Threshold for the Perception of the End of Movement (TPEM).	No difference in threshold level between the normal and deficient side was found.
Roberts <i>et al.</i>	1999	If QAG occurrence in ACL-deficient knees.	gait analysis system (Mac Reflex)	No QAG pattern occurred in the ACL-def. subjects. They assumed that the rate of QAG was less than previously are thought.

2.7. Taping

“Taping refers to the application of some type of adhesive backed tape (e.g. athletic tape or elastic tape) that adheres to the skin of a particular joint or to a limb (Sports Medicine Council, 1995).

There are differences between taping and wrapping. In taping, the tape always adheres to the skin; however in wrapping, a non-adhesive cloth wrap is used. The other factor is the elasticity of the fabric; wraps alone do not offer support and only provide compression whilst allowing joint or limb swelling. However, tape, if applied correctly, will provide both support and compression.

Taping is usually used in small joints such as ankle, wrist, and thumb or patellofemoral joint as it is believed to fix them effectively. However, on bigger joints such as the tibiofemoral joint it is used for various reasons. Knee supports and taping are prescribed for comfort, warmth, support, increased confidence, to increase stability, to increase proprioception, and to aid medial, lateral, anterior, posterior or rotatory stability. Taping as well as wrapping can be used before injury (as protective agents) and after injury during both the early, and/or later stages of injury management. Taping techniques in the early stages aims to reduce the inflammation, but taping in the later stages is used to assist the athlete in returning to activity (Sports Medicine Council, 1995).

2.7.1. Use of Taping in the Later Stages of Injury Management

1. It provides support for soft tissues (i.e. skin, muscles, tendon, ligament and joint capsule) by placing the injured structure in a position of lower stress.
2. It reduces the need for total immobilisation in minor injuries.
3. It enables the injured athlete to resume activity (often modified) which assists in regaining strength and flexibility of the joint or limb.

It should be noted that neither taping nor wrapping can create total soft tissue control. It cannot be also used as the only method of injury management. It can only function as part of a total injury management programme; a programme, which should be designed and monitored by qualified medical and paramedical personnel.

In spite of taping being costly and time consuming (The University of Washington spent \$40,000 in 1984 on tape during the football season alone (Hunter, 1985)), it is very commonly used in joint injuries, particularly for small joints. Unfortunately, very little is

known about its effectiveness as a ligament support in healthy or injured knees, or of its role in knee joint biomechanics.

2.7.2. The Effects of Taping on the Tibio-Femoral Joint

Due to the limited research available in knee taping, there is very little knowledge on the effects of taping of the tibiofemoral joint either *in vivo* or *in vitro*. Morehouse and Renstrom (IN Beynnon *et al*, 1991) were the pioneers in studying the efficacy of taping on the knee joint in 1970. They carried out the test while taping was extensively being used on the knee joint. They demonstrated that the effect of knee joint taping on valgus stability will have disappeared after only five minutes. This study also emphasised that although athletic tape initially provides a very good custom fit to the knee joint, with initial flexion-extension motion, the surrounding surface profile of the joint and musculature changes causes the tape to quickly become loose and ineffective. Roser *et al* (1971) studied the effectiveness of taping on the knee joint with and without braces. They suggested that the main benefit of taping unstable knees was psychological and that increased stability could not be demonstrated. Their report was rather pessimistic, but it does point out the lack of research in this area. Later on, Anderson *et al* (Anderson *et al*, 1992) studied an *in vitro* evaluation of a Lenox Hill knee brace and a Michigan type of spiral taping (Figure 2-3) in ACL-deficient knee cadavers. They aimed to evaluate if any of the above brace, tape, or combination, are helpful in restricting the anterior-posterior (A-P) and internal/external rotation of the tibia relative to the femur. They found that the Lenox Hill brace and the tape method used individually both restricted A-P translation and internal/external rotation of the ACL-deficient knee cadavers. They also found that the combination of the tape and the brace showed the greatest reduction in pathological movements. They concluded this was objective evidence of the restraining capabilities of these protective systems and may prove to be beneficial in the clinical setting.

Many investigators have confirmed the positive effects, mostly the proprioceptive effects, of wearing an elastic bandage. Barret *et al* (1991) emphasised that using an elastic bandage improved the joint position sense in subjects with impaired proprioception but not in those with good joint position. They concluded that wearing an elastic bandage around the knee improves joint position sense where this is deficient. Perlaud *et al* (1995) reported a 25% improvement of proprioception in normal subjects when using a 10-cm elastic bandage. They found that the potential beneficial effect of

the bandage lasted more than one hour during light thigh activity and was lost immediately when the bandage was removed.

In vivo studies have been carried out with regard to the proprioceptive effects of wearing an elastic bandage in an ACL-deficient knee. Jerosch (1996) reported the significant improvement of proprioception in both normal and ACL-deficient knee subjects following use of an elastic bandage. The result was in agreement with those reported by MacDonald et al (1996). Knutzen et al (1991) used an electrogoniometer and performed a controlled- speed overground straight running test on ACL-deficient subjects with and without an elastic support. With the elastic support, subjects tended to demonstrate greater swing and stance phase flexion and greater external rotation than without any support on the involved leg. They reported that these changes caused the kinematics of the involved limb to more closely match those of the healthy limb and concluded that may indicate the existence of a proprioceptive benefit of this device.

Despite the existence of various methods of knee taping in the literature (Figure 2-3) [(e.g. Michigan University's Method (Anderson *et al*, 1992), MacDonald's Method (Rovere *et al*, 1989), Alabama University's Method (Kenneth and Whitehill, 1991)], to date, with our best knowledge, there is no *in vivo* study to determine the effects of taping on any of the biomechanical variables of the knee joint, particularly in instability of the tibio-femoral joint in patients with an ACL-deficient knee.

It should be mentioned that contrary to bracing, which is NOT allowed in most sports competitions (Hunter, 1985; Hackney and Wallace, 1999), tape supports are allowed in all competitions (Hunter, 1985; Rovere *et al*, 1989). The taping used in this study was not supposed to be part of a management protocol in treatment of the injured knee. The main reason of taping in this study was to enable the researcher to evaluate the extent that knee biomechanics change towards a more normal knee position following the taping.

Figure 2-3 Three Methods of Taping Used for Knee Injuries.

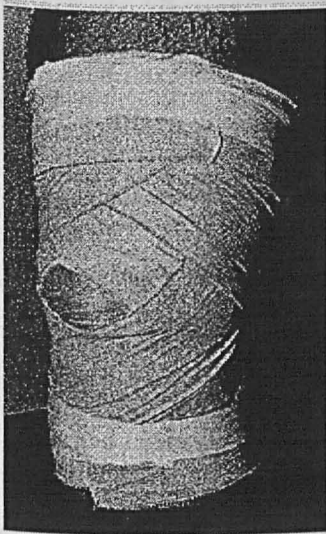

(1)

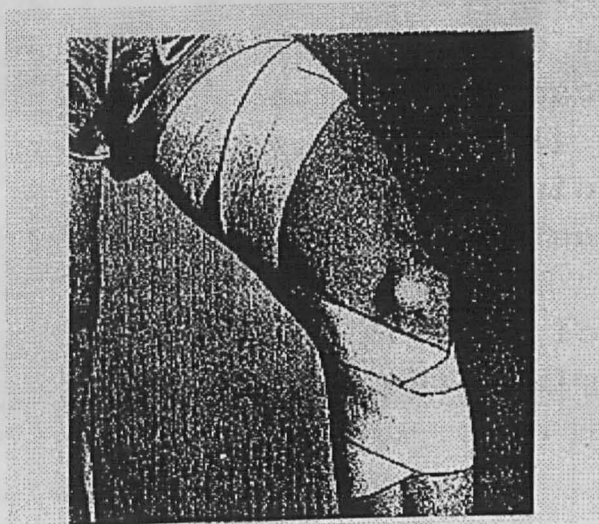

(2)

(3)

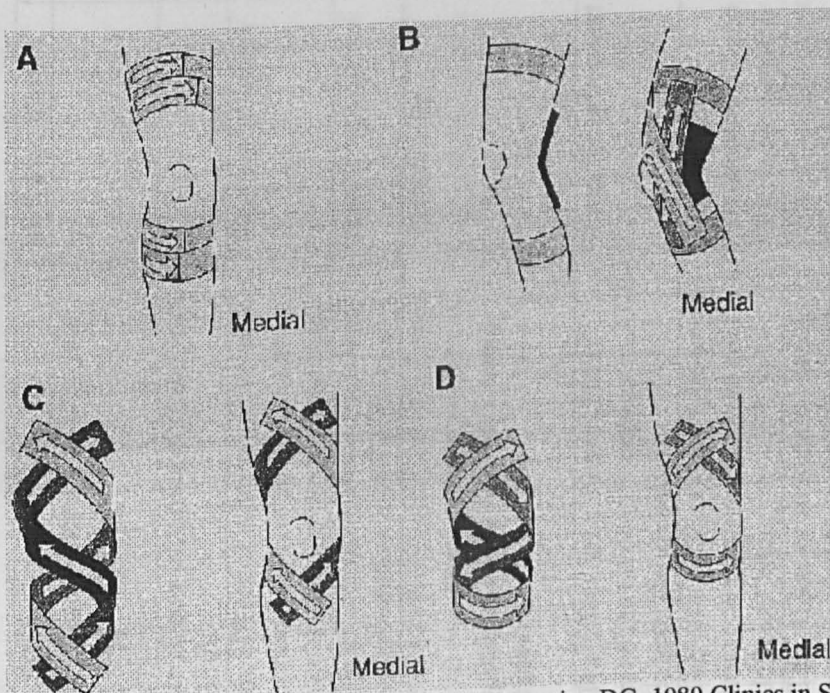

Knee Taping (1). [From: Dovece GD, Curl WW and Browning DG. 1989 Clinics in Sports Medicine, 8 (3): 511.

Knee Taping (2). [From: Writh KE, Whitehill WR. "The Comprehensive Manual of Taping and Wrapping Techniques". Published by: The University of Alabama, USA. 1991, Page 2-55].

Knee Taping, Michigan University Method (3). [From: Anderson, Kyle; Edward M. Wojtys; Peter V. Loubert; al., et. A biomechanical evaluation of and bracing in reducing knee joint translation and rotation. 20 (4), 1992, 416-21.

It should be noted that the taping used in this study is the Alabama University method (no. 2).

Table 2-7 Summary of the Studies Regarding the Effects of Taping in the ACL-Deficient Knees.

Researcher(s)	Year	Study	Instrumentation	Result
Morehouse	1970	The effects of taping in knee joint on valgus stability	-	Taping provides good initial custom fit to the knee, but will loosen quickly and ineffective after five minutes.
Roser	1971	The effects of taping on knee joint stability	-	The found the main benefit of taping on unstable knee was psychological.
Knutzen	1983	The effects of a brace and an elastic support brace on ACL-deficient knee during overground running.	Electrogoniometer	Elastic support made greater swing and stance flexion and external rotation.
Barret	1991	The effects of an elastic bandage on proprioception in deficient knee	proprioception test	Using an elastic bandage improved the position sense in all impaired knees, but not normal knees
Anderson	1992	The <i>in vitro</i> evaluation of a Lenox Hill brace and a Michigan type of spiral taping in ACL-def. knee cadavers.	Arthrometer	-Both tape and brace individually restricted AP translation and internal/external rotation of ACL-deficient cadavers. -The best results came when a combination of bracing and taping was used.
Perlaud	1995	The effects of a 10 cm elastic bandage on proprioception in ACL-deficient knee patients	Proprioception test	A 25% improvement in ACL-deficient knees lasted more than one hour
McNair	1996	The effects of a sleeve type knee brace on proprioception in ACL-deficient knee	Kin Com Dynamometer and Electrogoniometer	An 11% improvement in proprioception was detected in subjects who wore the sleeve.
Jerosh and Prymka	1996	The effects of an elastic bandage on proprioception in ACL-deficient knee patients	Proprioception test	Significant improvement was observed after wearing the elastic bandage

2.8. Summary of the Literature Review

The anterior cruciate ligament (ACL) is one of the most important ligaments of the knee and is frequently injured in sports and accidents. An ACL injury causes an increase in rotation and anterior excursion of the tibia on the femur. Using the current medical databases including Medline, CINHALL, Biomednet, PubMed and BIDS, a comprehensive literature review for the period 1960 to May 2001 was completed. A summary of the studies identified has been included as a Table chart at the end of each section. The key words used for literature search were *knee joint, brace, functional knee brace (FKB), ACL, ACL-deficient knee, sports and athletes, three-dimensional gait analysis, electromyography (EMG) and taping*. All efforts made to obtain the original articles through medical libraries and the inter-library loan facility.

◆ The Criteria for Selecting the Articles Were:

1. All studies should be related to the ACL-deficient knees (either *in vitro* or *in vivo* studies).
2. A gait analysis instrumentation containing non-optic/optoelectronic device /or optic/optoelectronic device should have been used in the study.
3. Those studies carried out *in vivo* and in dynamic situations were preferred to those carried out *in vitro* and in static situations.
4. Studies which focused on linear kinematics were preferred to those focused on angular kinematics of the knee joint.
5. Studies investigating the physiologic changes such as blood pressure and heart rate changes following bracing or taping were ignored.

The present literature review is mainly divided into two sections: a) some general information about ACL injury b) the gait analysis studies carried out on the ACL-deficient knee to find out the effects of orthoses (either bracing or taping) in the injured knees. In the first section, the biomechanics of the anterior cruciate ligament, the demography of the ACL injury and the mechanisms of the injury were briefly outlined. In the second section, the *in vitro* and *in vivo* studies in ACL-deficient knees were reviewed. In the section of “*in-vitro* studies”, studies on cadavers were reviewed and the kinematic data of the experiments on the cadaveric specimen with and without a brace were reviewed. In the *in vivo* studies, the studies carried out on the ACL-deficient subjects during either static or dynamic situations were reviewed. The kinetic, kinematic, force and EMG findings of the lower limb joints, mainly knee joint, during level walking

and running, on the ground or on the treadmill, with and without FKBs, were summarised. In the section on static *in vivo* studies, the studies of the effects of bracing on the normal or ACL-deficient subjects in a static position of the knee joint under low or high loads were reviewed. In dynamic studies, the *in vivo* research including the kinematic, kinetic, EMG and force data, gait adaptations in ACL-deficient knees and the quadriceps avoidance gait pattern were extensively reviewed. In the taping section, the effects of taping in management of soft tissue injuries and its effect on the normal and ACL-deficient knee kinematics were reviewed. Due to the importance of the translatory kinematics of the knee joint in the ACL-deficient subjects, this section has separately reviewed at the end of this Chapter.

It should be mentioned that most studies in the literature have been carried out on walking on level ground and studies that include walking or running on a treadmill are very rare. There is no study on the effects of bracing or taping on the ACL-deficient knees during treadmill tasks.

There are altered kinematics of knees in ACL-deficient subjects. Generally, it is believed that ACL-deficiency may not significantly change tibial rotation, but may cause a more pronounced distraction and anterior-posterior tibial translation. The controversy also exists if ACL-deficient patients actively use their quadriceps muscles or unintentionally ignore it and the so-called “quadriceps avoidance gait” pattern occurs.

Regarding the effects of bracing as a protective tool for an ACL-deficient knee, research from static FKB analysis showed that the brace was effective in reducing anterior displacement when a low force load was applied to the braced knee. As the loads increased however, the brace became less effective.

Research pointing out the effects of FKB in dynamic conditions including the invasive studies carried out by Beynnon and co-workers (Beynnon and Fleming, 1998; Beynnon *et al*, 1992; Beynnon *et al*, 1997; Fleming and Beynnon 2000) clarified that bracing produced a protective effect on the ligament by significantly reducing the strain values for anterior-directed loading of the tibia in low loads in *in vivo* activities. However, there is no non-invasive study to prove the positive effect of bracing on the ACL-deficient knee during different *in vivo* activities and sports.

To describe the kinematic changes following ACL-deficiency, a number of studies have been carried out. Some investigators have focused on cadaveric specimens (Wojtys *et al*, 1987; and 1990). Others have used some manual or operator-based

devices such as K-T 1000 arthrometer (Branch and Hunter, 1990; Branch *et al*, 1988; Bach *et al*, 1990) or the Electrogoniometer (Knutzen *et al*, 1983; Czerniecki and Lippert, 1988; Bagger *et al*, 1992; Hirokawa *et al*, 1992). Studies in which video analysis (optic and optoelectronic) devices have been used are the last group of studies which have been used to evaluate the effects of bracing in ACL-deficient knee (DeVita *et al*, 1992; Branch and Hunter, 1990; Vailas and Pink, 1993).

Despite some advantages seen in cadaveric studies such as directed instrumentation for measurement of strain and/or displacement, some disadvantages have also been highlighted by these studies. The disadvantages include lack of the normal dynamic responses of living tissues in cadaveric models and the impossibility of carrying out a true parametric evaluation of one brace versus another due to the different specimens used for the testing. In some dynamic *in vivo* studies an effort was made to duplicate physiological loading parameters other than tibial translation. Indeed, these researchers have aimed primarily to discover the effects of functional knee bracing on patients' performances and indirectly link the results with the tibial displacement, which may be inappropriate. In fact, finding a non-invasive and accurate method to analyse tibial movement in the *in vivo* situation is very difficult and the above-mentioned methods all have their individual inherent limitations. Cawley *et al* (1991) pointed out that the most important source of errors originate from the lack of advanced instrumentation and it was suggested that the results of most studies are not reliable and must be further investigated with optic/optoelectronic techniques even though they also have specific limitations.

Because of the limitations in most optoelectronic devices in directly measuring the small linear displacement of the tibia relative to the femur during a dynamic study, most efforts have been directed to analysing the differences in the angulatory kinematics, in conjunction with the other biomechanical parameters such as kinetic and EMG measurements between the normal and ACL-deficient knees.

Because of the controversy in the literature, there is currently no universal agreement about brace use in ACL-deficient knees. The question still remains "is a brace an appropriate treatment tool for ACL-deficient knees pre-operatively".

From the literature, it can be inferred that a brace probably cannot stop the excessive anterior tibial displacement, particularly during sports activities such as skiing and rugby. Therefore, is it appropriate to prescribe braces that allow patients to continue

sports activities without correcting abnormal knee biomechanics? In addition, does wearing a brace hasten the degenerative cartilage and bone changes seen in ACL-deficient individuals by fostering subjective feeling of stability despite abnormal loading conditions? Does brace behave different in treadmill exercise than that overground?

These questions have not yet been answered and the controversy still exists with respect to the extent that bracing can change the biomechanical parameters in an ACL-deficient knee. The effect of bracing on ground reaction force (GRF), muscle moment and electromyographic findings are also not clear.

Regarding the use of taping as a temporary support for the unstable knee, the lack of literature, particularly of *in vivo* studies, is obvious. In spite of the widespread use of taping particularly in 1970s-1980s, the early literature pointed out that taping on the knee acted as a non-valuable constraint or even functioned as a psychological prop to the sportsman. However, the *in vitro* studies, later on, showed good benefits of taping in unstable knee cadavers. The positive effects of taping to increase proprioception in impaired knees are now well accepted. However, in spite of its very common use in joint injuries, very little is known regarding the effectiveness of taping as a ligament support in healthy or injured knees as a prophylactic or functional tool. To date, there is no *in vivo* study to assess the biomechanical changes following knee taping in an ACL-deficient knee in dynamic low and high-force activities and to the extent that these changes can lead the deficient knee towards the safe and normal or a deteriorated condition.

In conclusion and with regards to the studies reviewed above, despite the extensive use of functional knee bracing or taping in athletes with an ACL-deficiency, in which appear to provide satisfactory subjective results, objective proof of their benefit remains controversial. It is highly recommended that carrying out a comprehensive study in different level of tasks (either on the ground or on the treadmill) with reliable results principally needs a high frequency (more than 120 Hz) automated three-dimensional gait analysis system. This system in combination with a force platform, surface electromyography and studying translatory kinematics of the knee will provide good insights of biomechanical effects of bracing or taping in some dynamic activities (Bartlett, 1997; Rahimi and Wallace, 2000a).

2.9. Translatory Kinematic Analysis of the ACL-Deficient Knee Joint - A Review of the Literature

Introduction

As time went on, it became apparent that simple eye measurements were not enough in motion analysis. Any motion that happened faster than 1/12 of a second could not be measured by human eye (Allard *et al*, 1995). Motion analyses is used for clinical and research purposes (Benedetti *et al*, 1998). Automated tracking systems for motion analysis have received increasing clinical acceptance. These systems are multi-camera systems, and they track either passive reflective markers or actively illuminated markers. An extensive search in the literature reveals that, generally two methods of analysis have been used in the study of ACL-deficient knees. These methods have also been used to find the effects of FKs in ACL-deficient knees. These procedures are direct (invasive) and indirect (non-invasive) methods.

2.9.1. Direct (Invasive) Methods

In this method, an invasive approach is used to evaluate directly the biomechanics of the knee joint in different conditions. The aim of this approach is to find the pure strain on the ACL in intact knees or measurement of the tibial displacement in ACL-deficient knees. Intra-cortical pin insertion (McClay, 1990; Lafortune *et al*, 1992; Reinschmidt *et al*, 1997; Reinschmidt *et al* IN: Ramsey *et al*, 1999) and arthroscopic implantation of different strain transducers into the intact anterior cruciate ligament in normal knees, are usually used to study the biomechanical behaviour of the intact ACL with and without bracing and in different weight bearing conditions (Beynon *et al*, 1992; Beynon *et al*, 1998; Beynon *et al*, 1996; Fleming *et al*, 2000). In an invasive method, threaded stainless steel, which are called intra-cortical pins (2.5-mm diameter), are implanted into the cortices of the iliac crest, thigh and shank. Having recorded the trajectories of the reflective markers placed on the pins during the given tasks, the kinematics of the lower limb are found (Lafortune *et al* IN: Ramsey *et al*, 1994).

Although the invasive method seems to be the best way to avoid surface marker artefacts, very few subjects would agree to undertake such an aggressive study. The knowledge about skeletal tibio-femoral kinematics is, thus, very limited, particularly in abduction/adduction and in internal/external rotation of the knee. In addition, preparation an invasive test is time consuming and needs local surgery. It can be identified from the

literature that Reinschmidt et al (1996 and 1997) and Lafortune (IN: Ramsey *et al*, 2000 and Lafortune, *et al* 1992) have carried out many studies to assess directly the behaviour of the ACL-deficient knee. Reinschmidt et al (1997) also tried to compare the results of the studies with surface markers with those using intra-cortical pins. They found very good consistency in only flexion/extension between skin and skeletal-based kinematics as the shape of the flexion/extension patterns were in general agreement across the subjects. However, poor agreement was found in the shape of skin and skeletal based abduction/adduction and the internal/external rotation curves across subjects. Nowadays, only sagittal plane data (flexion/ extension) is mostly studied in experiments with surface markers.

As the invasive method is not directly related to this study, the non-invasive studies will be reviewed more closely in this section.

2.9.2. Indirect (Non - Invasive) Methods

Due to limitations in running invasive studies, most gait analysis studies are carried out using an indirect method, and some surface markers are used instead of intra-cortical pins.

In these conservative methods, surface markers (active or passive) are attached to the specific parts of the limb. The markers can be directly mounted on the skin, or indirectly placed on the stick wands or special frames. Using a reconstruction algorithm, the coordinates of the markers are thereafter estimated in the laboratory system of the reference (Laboratory Coordinate System) in each sampled instant of time. From there, using constructed coordinates of a marker cluster, and a suitable mathematical procedure, a rigid body pose estimator, and the bone embedded frame (Local Coordinate System), six degrees of freedom are estimated versus time (Cappozzo *et al*, 1995).

Each direct and indirect method has its individual advantages and disadvantages. The greatest advantage of the non-invasive method is the easy of use and availability of the instruments in most gait clinics. However, some disadvantages are associated with this method. Based on rigid body mechanics, three-dimensional analysis assumes that markers placed on the body represent the position of anatomical landmarks for the segment (Nigg and Cole, 1999). However, surface markers may not represent the true anatomical locations, resulting in relative and absolute errors (Nigg and Cole, 1999). Relative errors are movements between markers with respect to each other, and are caused by skin movement relative to bone (Ishii *et al*, 1997). An absolute error is movement of a marker with respect to a specific body landmark (Nigg and Cole, 1999).

The above mentioned errors are of a particular concern during high dynamic activities (Reinschmidt *et al*, 1997). Consequently, considerable questions remain regarding what constitutes normal motion of the knee (Ishii *et al*, 1997). In conclusion, despite the disadvantages mentioned above, the non-invasive method is currently the most common and relatively reliable gait analysis system.

In a very recent study which attempts to directly assess the anterior tibial draw in patients with an ACL-deficiency, Beard *et al* (2000) introduced a new *in vivo* method by measuring the patella tendon angle (α). They measured the acute α angle by using special marker positions and VICON gait analysis equipment in 20 ACL-deficient subjects during walking on level ground. The angle was measured of both the injured and apparently healthy side as the control group in both stance and complete gait cycle. They also divided the patients into patients with severe symptoms of knee instability (frequent giving way), and moderate symptoms of instability (rarely or no giving way). They found that the mean patella angle for both the injured and healthy side was less than the mean patella angle during quiet standing ($P=0.005$) and reported that all patients reduced their anterior tibial translation to some extent during walking. No significant difference was found in both limbs. However, patients with severe symptoms had significantly increased anterior tibial translation on their injured side ($6.7^{\circ}\pm 2.3$) compared to non-injured ($10.1^{\circ}\pm 4.6$) in both quiet standing and walking. Conversely, patients who were less symptomatic were found to have less anterior tibial translation on their injured side ($7.9^{\circ}\pm 5.8$) when walking. They concluded that ACL-deficient patients are able to control tibial translation during walking, and some patients are better able to control the pathological translation during activity than others. This ability to control translation appears to directly impact on their symptoms of instability. They emphasised on the important role of the hamstring muscles for excessive tibial translation and pointed out that patients with less symptoms may be able to activate their hamstring muscles more efficiently to control tibial movement during locomotion.

2.10. Techniques to Reduce the Artefacts Caused by Surface Markers in Gait Analysis Studies

As mentioned earlier, many techniques have been developed to reduce the artefacts created following surface marker placement in gait analysis studies, although it cannot be eliminated. Generally, artefacts arise from markers' wobbling and movement on the underlying soft tissues leading the markers to show what are not necessarily real skeletal movements.

All efforts have been made to make the human body segment as rigid as possible in motion analysis systems. The ultimate aim in this area is to obtain a non-invasive *in vivo* data as accurately as invasive data. To date, there is no non-invasive *in vivo* method to accurately show the skeletal movement during dynamic activities, and some errors have been accepted in all gait analysis studies. Many investigators have introduced some new methods or have recommended some advice to reach to this aim. The details of the recommended methods are not explained in this review and only a summary of the recommendations is summarised.

Generally, some procedures have been described as effectively reducing the marker placement artefacts. They are as follows:

- Mounting the markers directly on the skin instead of placing them on the wands or sticks will remarkably reduce the wobbling artefacts (Cappozzo *et al*, 1997). This is of value, especially when a high-speed activity, such as running, is tested.
- Using a cluster design of markers for definition of each point in the segments (Cappozzo *et al*, 1996). In this technique a cluster of markers (usually three or more) are placed on each point of the segment (thigh or shank) (Andriacchi *et al*, 1998).
- Avoiding of placement of markers in correspondence with bone prominence where slipping effects are particularly evident (Cappozzo *et al*, 1997).
- Avoiding of placement of the markers on the muscle bulks since muscle contraction patterns can cause both deformation and rigid displacement of the cluster.

2.11. Recommendations for This Study

Following an extensive survey of the previous studies in ACL-deficient knees and the effects of bracing or taping on them, it seems that future research in this field should draw attention to the following subjects:

1. In spite of much literature regarding the effects of FKBs on ACL-deficient knee, the detailed changes of kinematic, kinetic and EMG parameters following knee bracing in ACL-deficient knees is still controversial, and further studies are recommended in this area (Vailas and Pink, 1993; Beynnon *et al*, 1996; Branch *et al*, 1993; Nemmeth *et al*, 1997; DeVita *et al*, 2000).
2. Although *in vitro* studies can show the quantified measurements in a specific area, dynamic tests in the physiological status are of much value. Cadaver models, however, are limited by the lack of active musculature and the changes in the compliance of soft tissues surrounding the thigh and calf that have been shown to affect the strain on the anterior cruciate ligament (Beynnon *et al*, 1992) Due to the above-mentioned problems, mostly *in vivo* studies are recommended (Cawley *et al*, 1991, DeVita *et al*, 2000).
3. Some researchers have established that following an ACL injury in one knee, a change in mechanics also occurs in the non-injured knee. Therefore, it is recommended that for studies of the injuries on one knee, using the non-injured knee as the control group is not appropriate and the researchers should use the normal knees of healthy subjects as the control group (Vailas and Pink, 1993; Berchuck *et al*, 1990).
4. The combination of kinetics, kinematics, and EMG studies, along with an investigation of the translatory kinematics will provide a better idea for researchers to deliberately assess the knee biomechanics following knee supports (Bartlett, 1997; Rahimi and Wallace, 2000a).
5. Although testing of very complex activities should be avoided, dynamic tests are preferred (Liu *et al*, 1995; Bagger *et al*, 1992; Hirokawa *et al*, 1992).
6. Due to errors identified when using non-advanced apparatuses which are operator-based tools, it is strongly recommended to use a high frequency optic/optoelectronic devices (Cawley *et al*, 1991).
7. Some investigators have pointed out the positive effects of taping on increasing the knee stability *in vitro* situation, and increasing the proprioception on ACL-deficient knee *in vivo* tests (Jerosch, 1996; Jerosch *et al*, 1998; Perlaud *et al*, 1995; McNair *et*

al, 1996; MacDonald *et al*, 1996). However, no literature is available regarding the effects of taping on kinematic, kinetic and EMG parameters in ACL-deficient knee patients during an *in vivo* study.

CHAPTER THREE - MATERIALS AND METHODS

3.1. General Methods and Specifications

This Chapter describes the study design, the population studied, ethical issues that were considered, the equipment used in the research and the procedures for collecting the data. The purpose of this study was to investigate the biomechanical effects of a functional knee brace (FKB) or taping on the ACL-deficient knee during walking on level ground (at the subject's preferred speed), walking on the treadmill (at 3.6 Km/hour) and running on the treadmill (at 10 Km/hour) speed.

3.2 Aims and Objectives of the Study

The Aims and Objectives of This Study Were:

- To compare gait parameters of the ACL-deficient subjects with healthy people during trials of walking on level ground and on the treadmill.
- To study if a FKB or taping is able to improve the impaired biomechanics of the ACL-deficient knees towards a more normal and thus safer pattern.
- To investigate the usefulness of functional knee bracing or taping to control the excessive anterior tibial translation and rotation found in ACL-deficient knees.
- To assess if limitation of the injured knee by brace or taping affects the kinematics and kinetics of the hip or ankle joints (the joints surrounding the knee joint).
- To monitor the changes in muscular parameters (EMG findings) in the muscles around the knee joint following knee bracing or taping particularly in treadmill activities.
- Finally, to find if the treadmill is safe and useful exercise equipment for the ACL-deficient subjects.

3.3. Hypotheses to Be Tested

The hypotheses tested were the following:

- I – The use of a FKB can improve the impaired biomechanics of the ACL-deficient knee towards a normal and safe pattern and consequently prevent the rotary instability, which may expose the adjacent supporting ligaments and menisci to further degeneration.

II – Since taping is a type of knee support (although less strong than bracing), it is assumed that using taping as a temporary support for ACL-deficient knees also enables them to actively participate in exercise.

3.3.1. Detailed Hypotheses

- In kinematics, it is hypothesised that either brace or tape (brace more than tape) will decrease the range of motion (ROM) of the knee and is likely to increase the hip and ankle joints ROM as a compensatory effect. It is also hypothesised that following bracing or taping, the angulatory positions of the knee, hip and ankle joints will be altered so that the new positions will improve the injured knee towards a safer position.
- In kinetics, it is hypothesised that bracing or taping (brace more than type) will reduce the knee joint moments and power and will increase the hip and ankle joints kinetic values.
- In EMG studies, it is hypothesised that brace or tape (brace more than tape) will decrease the quadriceps, hamstring and gastrocnemius activities.
- Finally, for force data, we prepared no hypothesis, because this is such a controversial area.

3.4. Recruitment of Subjects

3.4.1. ACL-Deficient Subjects

Fifteen unilateral ACL-deficient subjects were recruited from the waiting list for ACL-reconstructive surgery from the out-patient clinic in Queen's Medical Centre, University Hospital, Nottingham. The patients were selected based on the inclusion and the exclusion criteria of this study. Efforts were made to collect patients with no injury other than the ACL-deficiency. Three of these patients were recruited in July 1999 and were tested in the pilot study. The other twelve patients were recruited in July to September 2000. When the subjects were selected, a letter of invitation, signed by Mr. Ian Forster, Consultant Orthopaedic Surgeon, Specialist in ACL reconstruction surgery and the Clinical Director of the study was sent to the patients. A subject information sheet, a consent form, and a copy of the project written in language understandable to lay persons was sent to all the subjects along with a timetable of the testing days.. A letter was sent to each patient's GP stating the time, type and the methods of the study.

Thirteen patients (of the fifteen) were able to take part in all levels of tasks in the study. Of the other two patients, one in the pilot study and one in the main study were not able to take part in running trials and took part only in the walking tests.

3.4.2. Control Group

Based on the inclusion and exclusion criteria of the study, fifteen apparently healthy subjects were also selected as the control group. Efforts were made to match the subjects with the ACL-deficient patients. The subjects were matched for age, sex, height, weight, and activity level. The normal subjects were fifteen volunteers, mostly PhD students based at the University of Nottingham. All subjects were interviewed by the investigator to confirm the following criteria:

1. No previous injury or history of knee surgery either on the test or contralateral side;
2. No leg length discrepancy;
3. No functional limitations of the hip, knee or ankle joints;
4. Ability to run on the treadmill with a relatively high speed (10 Km/hour);
5. No medical history of musculo-skeletal or neurological problem.

3.5. Clinical Description of the Patients

The orthopaedic surgeon, on the basis of the clinical findings, had made the initial diagnosis of an ACL-deficient knee. In all cases the ACL-deficiency was confirmed by either arthroscopy or MRI or both. Only patients with unilateral ACL-deficiency were recruited into this study.

3.5.1. Inclusion Criteria

Inclusion criteria for the subjects were as follows:

1. Age between 20 and 40 years.
2. Diagnosed as a unilateral ACL-deficient knee either by arthroscopy or MRI.
3. No additional injuries, such as meniscal or collateral injuries were present.
4. No severe pain, swelling, or limitation of motion affecting the patients walking or running patterns.
5. Confidence to run on the treadmill for at least 15 minutes without any problem;
6. All normal and ACL-deficient subjects should have a history of training in amateur sports activity (twice per week).

3.5.2. Exclusion Criteria

Exclusion criteria for the subjects were as follows:

1. Other musculo-skeletal injuries which might affect the gait pattern.
2. Co-existing injuries or complex injuries of the knee joint (e.g. ACL-deficiency with capsular injuries).
3. Lack of confirmation of ACL disruption by either arthroscopy or MRI.

4. Acute ACL injury (less than 6 months) or chronic; long-term ACL-deficiency (more than 7.5 years past injury).

Screening involved arthroscopy or MRI examination, physical examination tests by the researcher, and the use of the Lysholm Score to assess functional knee stability (see Appendix for the related forms).

3.6. Ethical Committee Approval

The study was granted ethical approval by the Research and Development Directorate of the Queen's Medical Centre, University Hospital, University of Nottingham in September 1998 prior to all the experiments involving human volunteers (see Appendix).

3.7. Test Modes

The subjects in this study were tested using the following situations:

- A) The ACL-deficient subjects were tested in three conditions: while with a FKB, with a spiral method of taping and without any bracing or taping.
- B) All the control subjects were tested only without bracing or taping.

All subjects (both the ACL-deficient and the control groups) were tested in three testing modes including walking on level ground at the subject's preferred speed; walking on the treadmill at 3.6 Km/hr (1m/sec; and running on the treadmill at 10 Km/hr (2.8m/sec).

3.8. Outcome Measurements

In this study, the outcome measurements were divided into two groups: primary and secondary measurements. The primary measurements include the kinematic and kinetic parameters of the ankle, knee and hip joints and the force and EMG data analysis. The secondary measurements included the Lysholm score of each subject showing the general stability of the subject's knee. This value was used in interpretation of the data under discussion.

3.8.1. Primary Outcome Measures

Various instrumented gait analysis systems allowed the study of different aspects of gait. The parameters chosen for this study were kinematic, kinetic, ground reaction force and EMG parameters.

Kinematic Analysis

To measure the kinematics of the ankle, knee and hip joints during the tasks, a Coda *mpx30* motion analysis system with a 200 Hz frequency was used. The parameters were selected to characterise the dynamic ROM of the joints and to facilitate comparison between different trials with different supports, not only graphically, but also numerically and statistically. The following kinematic parameters were studied in each trial on the ankle, knee and hip joints:

Ankle Joint

The following parameters were considered in the ankle joint kinematics:

- (a) Ankle position angle at foot strike.
- (b) Maximum ankle dorsi-flexion.
- (c) Maximum ankle plantar flexion.
- (d) Average ankle position in stance phase.
- (e) Average ankle position in swing phase.

Knee Joint

The following parameters were considered in the knee joint kinematics:

- (a) Knee angle at foot strike.
- (b) Maximum knee flexion in stance.
- (c) Maximum knee flexion in swing.
- (d) Average knee angle in stance phase.
- (e) Average knee angle in swing phase.
- (f) Knee angle at midstance (only when walking on level ground).
- (g) Time to reach to the mid-stance point (only when walking on level ground).

Hip Joints

The following parameters were considered in the hip joint kinematics:

- (a) Hip angle at foot strike.
- (b) Maximum hip extension in stance.
- (c) Maximum hip flexion in swing.
- (d) Average hip angle in stance phase.
- (e) Average hip angle in swing phase.

In addition, the total range of motion (ROM) of the ankle, knee and hip joints were calculated and the ROMs of the three lower limb joints were summated and called the “ROM support”.

Kinetic Analysis

An analysis of moments and power was carried out together with temporo-spatial measures, a kinematic analysis, and finally the EMG findings provided a complete description of the gait. The following parameters were studied for each trial on the ankle, knee and hip joints:

Ankle Joint

The following parameters were considered in the ankle joint kinetics:

- (a) Maximum ankle dorsi-flexion moment.
- (b) Maximum ankle plantar flexion moment.
- (c) Maximum ankle generation power.
- (d) Maximum ankle absorption power.

Knee Joint

The following parameters were considered in the knee joint kinetics:

- (a) Maximum knee flexion moment.
- (b) Maximum knee extension moment.
- (c) Maximum knee generation power.
- (d) Maximum knee absorption power.

Hip Joint

The following parameters were considered in the hip joint kinetics:

- (a) Maximum hip flexion moment.
- (b) Maximum hip extension moment.
- (c) Maximum hip generation power.
- (d) Maximum hip absorption power.

Please note that all moments calculated in this study are “internal moments” and, in some published papers two other parameters have been mentioned which are “Support Moments” and “Area Under the Curve” (Winter, 1990; DeVita *et al*, 1998; DeVita *et al*, 1997; Hof, 2000). The calculation of these parameters is briefly explained below.

The “Support Moments”

The sum of all flexor and extensor moments of the ankle, knee and hip has been summated and is described as the “Support Moment”. This value helps the researcher understand the contribution of all muscles to the overall forces in the lower limb. For instance, if the torque at the knee is less as a consequence of ACL-deficiency, yet the “torque supports” are the same as in a normal knee, then the contribution of torques from other joints, ankle and hip, must be greater. This will be helpful particularly in finding the compensatory torque changes in the joints above and below the main joint under study.

The Area under Curve (AuC) in This Study

This is the sum of all the moments or joint power in the whole stance phase or during a particular part of stance. This is a similar concept to the root mean square (RMS) used in relation to EMG analysis. This AuC value can be calculated by adding all the desired points (depending on the joint being studied) and multiplying by the time interval (e.g. if the data are processed at 200 Hz, the time interval is $1 / 200 = 0.005$). Some researchers have used different percentages from those mentioned here and then calculated the AuC. For moments in the ankle, only positive values were used to calculate the AuC during stance. For the knee, we calculated two variables: 1) the sum of positive values in 0-50% of stance phase and 2) the sum of positions of the values in 0-100% of the stance phase. In the hip joint, we calculated three variables: 1) only positive, 2) only negative and 3) the sum of all positive and negatives values throughout the stance. For joint power, only positive, only negative and the sum of both positive and negative values were calculated during 0-100% of stance for the ankle, knee and hip joints. The sum values were then multiplied by 0.005 and called “angular impulse” or “Impulse Moment”. The unit of the AuC in moment is NMs/kg and in joint power is Ws/kg or Joules/Kg in this study. The AuC was also calculated for vertical force and called “impact impulse force” (Ns/kg).

Ground Reaction Force Data Analysis

The three-dimensional ground reaction force (GRF) was recorded only during walking on level ground. When the subject landed their testing foot on the force plate the vertical or impact (Z), the medio-lateral shear (Y) and the antero-posterior shear (X) force vector values were recorded.

From the recorded force data, the following variables were studied in this experiment:

- (a) The maximum vertical impact force (VIF_{peak}).
- (b) The time to reach the vertical impact force (VIF_{time}).
- (c) The maximum vertical active force (VAF_{peak}).
- (d) The time to reach the vertical active force (VAF_{time}).
- (e) The maximum antero-posterior shear forces (both negative and positive in X vector).
- (f) The AuC for vertical force (impact impulse force) was also calculated and compared for different supports.

EMG Analysis

Myoelectric signals were recorded from four muscles around the knee joint: rectus femoris, medial hamstring, vastus medialis and gastrocnemius. Surface electrodes were used for the electromyography.

The parameters of the EMG data were amplitude (Peak) and the root mean square (RMS) of the signals. The EMG signals in this study were automatically rectified by Coda software and were filtered with a 15 Hz low pass filter.

Definition of Mid-Stance in Walking on the Ground

Usually, four methods are suggested to define the mid-stance of the gait cycle clinically during walking on level ground. These are a) determining 50% of the stance phase; b) 30% of a gait cycle; c) the lowest force value between the first and second peak wings and d) the point of the gait cycle in where the fore-aft force vector changes the direction from anterior to posterior (Perry, 1992, Kirtly 1999). From these methods, we chose the last one as it was found to have greater reproducibility in our pilot study. Monitoring the force data, we determined the A-P shear force value when it changed from negative to positive, indicated by the change of the direction of the body from initial stance to the terminal stance, and we have called that mid-stance.

3.8.2. Secondary Outcome Measure

Lysholm Score Questionnaire

The Lysholm score is a professional-assessed scale for quantifying symptoms during daily activities following a knee ligament injury. It does not evaluate the absolute stability or ligament integrity of the knee. It does, however, evaluate the severity of

symptoms that may be associated with knee instability, ligament injury or other lower extremity injury or disease. There are 8 parts to the score (limp, support, locking, instability, pains, swelling, stairs and squatting) with a weighted scoring given to each response. A maximum score of 100 is given where no problems are experienced during daily activities and 0 is given for the most severe symptomatology.

This scale has frequently been used by other investigators (Lysholm & Gillquist, 1982; Smith *et al*, 1987; Shaw *et al*, 1991; McLoughlin & Smith, 1992; Ellis *et al*, 1994; Friden *et al*, 1990) and is a universal validated knee scoring scales. This questionnaire measures the limping (5 points) (5 = ‘no limp’ to 0 = severe and constant’), support (5 points) (5 = ‘no support’ to 0 = ‘weight-bearing impossible’), locking (15 points) (15 = ‘no locking and no catching sensations’ to 0 = ‘locked joint on examination’), instability (25 points) (25 = ‘never giving way’ to 0 = ‘instability on every step’), pain (25 points) (25 = ‘no pain’ to 0 = ‘constant pain’), swelling (10 points) (10 = ‘no swelling’ to 0 = ‘constant swelling’), stair-climbing (10 points) (10 = ‘no problem in stair-climbing’ to 0 = ‘impossible’), and squatting (5 points) (5 = ‘no problem in squatting’ to 0 = ‘squatting impossible’).

The questionnaire was chosen because it is simple, valid and reliable in patients who had an ACL-deficiency (Lysholm and Gillquist, 1982; Friden *et al*, 1990; Johnson and Smith, 2001). This investigator used the Lysholm Score results to categorise the patients into copers and non-copers according to Snyder-Mackler’s category (Snyder-Mackler *et al* IN: Roberts *et al*, 1999) to find any correlation between the score of each group and the occurrence of, for example, the QAG pattern.

3.9. Gait Analysis Equipment

Instrumented gait analysis was performed to provide objective measurements of gait. The biomechanical values including kinetic, kinematic and EMG data were collected. The floor area of walkway in the main study was 16 meters long and 6 meters wide and contained two force plates embedded in the floor. The gait analysis equipment used in this study consisted of:

- A CODA *mpx30* motion analysis system (Figure 3-2).
- An AMTI force plate (Figure 3-3).
- A Telemetered Dynamic Electromyography (EMG) system (Figure 3-4)
- A motorised treadmill (Figure 3-5).

All data were obtained from subjects walking and running barefoot to eliminate variations caused by shoe design.

3.9.1. CODA mpx30 Motion Analysis Unit

The acronym “CODA” stands for Cartesian Optoelectronic Dynamic Antropometer (Mitchelson, 1990). The first design studies for the CODA system were carried out at the Department of Ergonomics and Cybernetics at Loughborough University, UK in 1970 and a primary device was completed in 1973 and commercially marked as CODA 3 (Figure 3-1). This instrument provided much better performance using 3 mirror scanners, rather than television, to capture the three-dimensional coordinates of limb position (Mitchelson, 1990).

The detection system consisted of compound cylindrical lenses in three electronic cameras. This was an advanced system much better than any others used at that time. The main disadvantage of the system was that it was limited to 8 markers. Further development of the CODA system continued between 1985 and 1987 and an improved version of CODA-3, called CODA *mpx30* (Figure 3-2) was produced, meeting all the initial design goals.

The CODA *mpx 30* differs from the old CODA-3 in several important ways:

1. It is all solid state with no moving parts, so it is more reliable.
2. It is much smaller and lighter, and therefore portable.
3. The markers are active LEDs, not passive corner cube prisms. This allows the use of many more markers with completely secure marker identification.
4. Markers can be placed as close together as desired which is not possible when passive markers are used e.g. in video based mirrors.
5. The system uses a scanner unit not rotating mirrors.
6. The equipment has huge sampling rates of up to 800 Hz (the sampling rate reduces as the number of markers increase).
7. The software is much more extensive, sophisticated and user friendly and is Windows based.

The Limitation of the CODA *Mpx30* are as Following:

1. Inability to record both limbs with a unilateral system. A second CODA system is needed for contra-lateral side.

2. The CODA *mpx30* system is not a well-known system due to the problems experienced in the early design of CODA-3 and this has resulted in limitations with regard to information exchange between researchers.

The Main Differences between CODA *Mpx30* and other Motion Analysis Systems are:

1. High resolution: It has a resolution which is at least five times better than other systems which are based on video cameras such as VICON.
2. High dynamic range: It also has a greater dynamic range which means that fine details can be seen, even in large scale movements, with much greater resolution than with other motion analysis systems.

The other systems, which are commercially available, use either active infrared LEDs or passive markers.

The CODA *mpx30*, used in this study, is an automated optoelectronic computerised 3D-movement analysis system and recorded the temporospatial parameters and functional range of motion of the ankle, knee and hip joints. According to the manufacturer's specification (Charnwood Dynamics, 1999; Charnwood Dynamics, 2000), the CODA *mpx30* has a measurement resolution of 0.1 mm horizontally and vertically in the plane perpendicular to the optical axis of the camera (in X and Z), and a 0.6 mm parallel to the optical axis (Y) at a distance of three meters from the CODA scanner unit. It is capable of locating targets with 0.1-0.2 mm resolution in the X, Y and Z axes. The CODA *mpx30* system was recognised as one with a very high accuracy when compared with all gait analysis systems (Richards, 1999).

CODA *mpx30* uses small infrared light emitting diodes (LEDs) (Figure 3-6) which are placed on the subject to be examined. Each of the markers is number coded for automatic identification. The markers were directly attached to the skin using double backed adhesive tape. These markers are powered by small rechargeable battery packs, which are placed on the subject close to the markers (Figure 3-6). Each battery pack has two small sockets into which the individual LED markers are plugged. Each socket has a number, which indicates the identity of the marker to be plugged into that socket and the movements are tracked by the CODA *mpx30* sensors.

3.9.2. Force Plate

Two force platforms were used in this study. In the pilot study, a Kistler force plate (Kistler 9261 A, 600×400×60 mm, Kistler Instruments Limited, Switzerland) was integrated with the CODA *mpx30* system to record the force data (Figure 3.3). Since the CODA *mpx30* system was transferred from the Queen's Medical Centre to Nottingham City Hospital after the pilot study, an AMTI (Advanced Mechanical Technology Incorporated) force plate was used in the main study. A six-component AMTI (AMTI OR6-7-1000, Watertown, MA, USA) force platform (Figure 3.3) interfaced with the CODA *mpx30* was used to collect the force data. The advanced AMTI force plate used in this study was mounted onto a steel frame and embedded in concrete to reduce system vibration. It incorporated strain gauges mounted on four precision strain elements to measure forces and moments. A DSP card, implemented in the PC, transferred the force data to the PC, which was running the CODA software.

When the foot touches the force plate the reaction forces are converted into electrical signals relating to their direction and magnitude. An inverse dynamic method is used to calculate the moments and power that have been generated during walking over the ground. The force plate was positioned on the middle of the walkway, with its top surface level to the floor surface.

3.9.3. Telemetered Dynamic Electromyography System

The integrated telemetered Charnwood Dynamic electromyography (EMG) system (Figure 3-4) consists of pre-prepared adhesive conductive electrodes (silver-silver chloride, 6 mm in diameter) that are attached over the muscle to be tested. The electrodes connect to pre-amplifiers via press-studs. The amplifiers connect to the transmitting telemetry unit via light wires.

The pre-amplifier modules are wired to a belt pack in which analogue data is converted to digital data for transmission via infrared telemetry to the host computer. The Motion Analysis application software processes and displays the EMG data. The EMG signals are full wave rectified and sampled at a constant rate of 1600 Hz, giving an effective frequency bandwidth of 35–800 Hz. Successive samples of a given channel are then averaged and the result transmitted at 200 Hz. Transmission of the EMG signals occurs during time intervals when the CODA markers are not emitting light. The advantage of the dynamic EMG telemetry system is that during recording there is no need for wires to

trail from the subject, which might alter gait, particularly in patients who have impaired locomotion.

3.9.4. Treadmill

The treadmill used in this study was a light motorised commercial treadmill (Life Fitness 8500, USA). The treadmill was a stand-alone unit with its own programme and a user-friendly console displaying a host of visual feedback facilities and easy-to-follow prompts and instructions. During the tests, the side stands of the treadmill were removed to allow the markers to be viewed fully. A zero degree inclination was used in this study and the subjects were fully instructed in the safe use of the treadmill. The emergency stop button and belt were shown to the subjects and they were encouraged to stop the treadmill at any time of the test, if necessary. In addition, the investigator closely supervised the subjects during the tests, particularly during running on the treadmill. None of the subjects reported any pain or discomfort during the tests on the treadmill or while walking on level ground.

To provide more stability and security, the subjects in this study were advised to hold the front bar of the treadmill while running on the treadmill. However they were specifically discouraged from leaning forward abnormally while running.

3.9.5. Functional Knee Brace

A Legend DonJoy Functional Knee Brace (Smith & Nephew, DonJoy Carlsbad, California, USA) is frequently prescribed for ACL-deficient patients both pre and post operatively as a standard knee brace. This brace is known as one of the active braces that working according to the 4-point of leverage dynamic bracing system designed to suppress abnormal tibial translation. This brace was applied by the author to the involved knee of each ACL-deficient subject. The author is a qualified physiotherapist with experience of working with knee braces. The brace was made with a uni-axial hinge, post, and strap design. It has a rigid thigh and calf restraint to fit each subject's thigh and leg respectively. Additional Velcro straps were used to hold the brace in place. The adjustable hinge was set with a 10-degree extension stop, which is a generally accepted standard to prevent hyperextension of the knee (Figure 3-7). The brace was applied according to guidelines prescribed by the manufacturer. The brace size was selected for the patients by measuring the thigh circumference (15 cm above the patella) and using the size chart provided by the manufacturer.

3.9.6. Taping

In this study, the guidance of Kenneth E Writh and William R Whitehill in their book on “The Comprehensive Manual of Taping and Wrapping Techniques” (The University of Alabama, published by Cramer products, Inc. 1991 Cardner, Kansas, USA, Page: 2-55-6) when using taping for the tibio-femoral joint.

The taping, used in this study, is a type of elastic adhesive bandage “Elastoplast” 7.5cm × 4.5cm (stretched), (Smith & Nephew, Medical Limited, Hull, England) and consists of five stages (Figure 3-9).

The above method of taping was selected from the three available methods of taping of the tibiofemoral joint (Figures 2-3), following the advice of Mrs Rose Macdonald, former Director of Crystal Palace Athletics Club, London, who is an international expert in the area of taping. The tape used in this study was 3-inch elastic tape. A 2-inch adhesive tape was also used for applying an anchor to secure the taping to the thigh region. To prevent any compression pressure on the popliteal space of the knee, gauze with Vaseline was applied to the posterior aspect of the knee before commencing taping. When the taping was finished, the subjects were asked to perform a gentle activity for five minutes to ensure that the taping would be comfortable during the test.

The author was fully instructed in the taping by Mrs Macdonald in a one-day training session. I practised taping many times so that the instructor could confirm that I was performing the taping correctly. In addition, in order to avoid mistakes during the real tests, I filmed the whole of Mrs McDonald’s session of taping instruction and frequently reviewed it in order to remind me of the details of the taping method.

3.9.6.1. Taping Procedure in This Study

Before commencing taping, the general pre-taping procedures, including shaving and drying of the area, and covering the posterior aspect of the knee (popliteal space) with gauze and lubricant (Vaseline in this study), were performed. While the subject was in a comfortable standing position with the knee at 30 degrees flexion, an anchor of 3” (7.5 cm) elastic tape was applied around the upper third of the thigh (stage 1). Then, using the 3” elastic bandage, the taping began on the lateral aspect of the lower leg, approximately 1” (2.5 cm) below the patella. The tape encircled the lower leg anteriorly, then the medial side, continued to the posterior aspect and returned to the lateral side. Just below

the patella, the tape was angled to cross the medial joint line and popliteal space, and spiralled up to the anterior portion of the anchor on the upper thigh (stage 2). The second strip of tape began on the anterior aspect of the proximal anchor (thigh), crossed the medial portion of the thigh, covered the popliteal space, encircled the leg, crossed the popliteal space again and finished at the anterior aspect of the proximal anchor on the thigh (stage 3). The stages of the second strip were repeated again (stage 4) and a 2" adhesive tape was applied as a further anchor to secure the anchor on the thigh (stage 5) (Figure 3-8).

To avoid loosening, the FKB or taping was regularly checked during the tests. Interestingly, contrary to Morehouse and Renstrom's report (Morehouse and Renstrom, 1991), the taping used in this study was so strong that the patients felt the effect of its compression until the end of the study. No discomfort or allergic rashes were reported following the bracing or taping.

3.10. Other Measurements

In order to calculate the kinetic parameter of gait it is necessary to record the subject's anthropometric measurements. These include the subject's height, weight, distance between two ASIS as the front pelvic frame, and the distance between ASIS and PSIS of the testing side as the depth of the side pelvic frame. The width of the ankle and knee joints and the lengths of the femur and lower leg were also measured. The height of the subjects when barefoot was measured using a standard wall mounted scale. Weight was also measured barefoot using an electronic weighting scale. A manual calliper was used to measure the width of the ankle and knee joints while the subjects were lying supine with their knees extended. A tape measure was also used to identify the distance between the greater trochanter of the femur and the knee joint line as the length of the thigh. The distance between the centre of the knee joint and lateral malleolous of the ankle was also measured as the length of the lower leg.

3.11. Recording of Dynamic EMG

3.11.1. Electrode Placement

A Velcro strap was used to attach the Telemetry transmitter unit to the centre of the subject's back and then secured. A fully adjustable strap was fitted over the shoulder held in position by Velcro.

3.11.2. Skin Preparation

To reduce skin resistance the electrode locations were shaved, if necessary, and gently cleaned using a Medi-Swab isopropyl alcohol (BP70% V/V, Seton Product Ltd, England). The area was then left to dry.

3.11.3. Muscles Tested

The following four muscles were selected in this study and surface electromyography was performed simultaneously with CODA mpx30 and force plate recording:

- 1) Rectus femoris; 2) Vastus medialis; 3) Medial hamstring; 4) Gastrocnemius.

3.11.4. Position of the Electrodes

The EMG electrodes were placed along the muscle fibre orientation of the muscles. The EMG reference electrode was placed over the glutei muscles. The placement of the EMG electrodes for all muscles took place when the subjects were in a standing position.

The electrode position for the rectus femoris muscle was located at a point halfway between the ASIS and the superior pole of the patella. The electrode for the medial hamstring muscle was placed on the lateral border of the muscle, about 13 cm above the insertion on the tibia. For the vastus medialis muscle the electrode was placed over the muscle mass about 6 cm from the medial border of the patella. The electrode for the gastrocnemius muscle was placed over the visible muscle bulk on the medial head of the muscle. These are the standard sites used for EMG electrode placement in routine clinical practice (Cram *et al.*, 1998).

3.12. CODA's Marker Placement Set-up

In the unilateral CODA's standard marker placement set-up (Figure 3-10), eleven markers are positioned on the CODA wands and attached to specific places on the lower limb (Charnwood Dynamics, 1999). Three markers are placed on the pelvic area attached to the pelvic frame (markers no. 1-3). On the thigh region, a wand is placed on the supra chondylar area. A marker (marker no. 5) is placed on the back part of the wand and is called the "Post.Fem" marker. One marker is also placed on the front part of the wand (no. 6) and called the "Ant.Fem" marker. On the leg, the wand is placed on the upper third of the leg and two markers are placed on it. One is called "Post.Tib" and is placed on the back part of the wand (no. 7) and the other one is called "Ant.Tib" and is placed on the front part of the wand (no. 8). Three markers are also directly mounted onto the foot area on the lateral malleolous (no. 10), lateral calcaneous (no. 11) and on the base of the 5th metatarsal bone (no. 12). All markers are placed to allow a sagittal view. Since the present study encompasses tests on the treadmill with a relatively high

speed, to reduce the risk of marker movement artefacts the use of wands was found inappropriate in this study and prone to severe wobbling. On the advice of Mr. Pickering, CODA's mathematician and Professor Roger Woledge⁶, (RNOH, Stanmore, London) mounting all markers directly onto the skin was considered to be the best way of fulfilling all of the desirable criteria. This method of marker placement – called the “clustering method” - was used in this study and is a modification of CODA's standard marker placement set-up. Some researchers have already reported different types of clustering marker placement in their studies (Andriacchi *et al*, 1998; Cappozzo *et al*, 1997).

3.13. Clustering Marker Placement Used in This Study

As Figure 3-11 shows, the main difference between the CODA's standard marker placement set-up and the “clustering marker” set-up, used in this study, is the increased number of markers used in the clustering method. In this method a group of two or three markers were placed as a triangle at each point of the thigh or leg instead of a single marker and that segment was then defined. The marker placement sites were chosen based on the advice of Cappozzo (Cappozzo *et al*, 1997) - see Chapter 2, as these sites were associated with the least movement artefact. No wand was used in this method and all markers were directly mounted onto skin. Three markers were mounted on the anterior upper part of the thigh (named “Ant.Thigh Cluster”); and three markers on the posterior of the upper thigh (“Post.Thigh Cluster”); and two markers on the lateral supracondylar part of the femur (“Above Knee Cluster”). All markers were mounted in sagittal view of the affected limb as is the standard CODA practice. The same method of marker placement was used on the lower leg, in which three markers were placed on the anterior proximal tibia (“Ant.Leg. Cluster”); three markers on the posterior proximal tibia (“Post.Leg. Cluster”); and two markers on the lateral malleolous to define the ankle joint (“Ankle Cluster”). One marker was placed on the heel, and one marker on the tuberosity of the fifth metatarsal bone to define the foot segment. The pelvic frame and its related markers were placed according to the standard set up.

After data collection and during data processing, a virtual marker was defined in the centre of each cluster to indicate the resultant movements of the markers constructing the cluster. Therefore, "Virtual Ant. Thigh", "Virtual Post. Thigh", and "Virtual Above

⁶ Professor Roger Woledge, Director and Professor of Experimental Physiology, Human Performance Laboratory, RNOHT, Stanmore, London.

Knee" points were defined for the three clusters on the thigh. Using the same method three virtual points were also defined on the lower leg and called "Virtual Ant.Leg.", "Virtual Post.Leg.", and "Virtual Ankle". The foot segment was defined by a virtual ankle, a real heel and a real toe (5th metatarsal) marker. Therefore, each virtual marker in this method showed the average movement of the cluster containing two or three real markers. This method is effectively a modification of CODA's unilateral standard marker placement set-up. It should be emphasised that the "Virtual Ant.Thigh", the "Virtual Post.Thigh" and the "Virtual Above Knee" markers were used to construct the "Ant.Fem." marker, which was also created as a virtual marker. Similarly, the "Virtual Ant.Leg.", the "Virtual Post.Leg." and the "Virtual Ankle" markers were used to construct the "Ant.Tib." marker, which was also created as a virtual marker. The "Post.Tib." marker was defined as a virtual marker using the "Virtual Ant.Leg." and the "Virtual Post.Leg" points. The knee joint was defined as follows. The three non-collinear markers in the thigh region were the "Ant.Fem." (virtual), Virtual Above Knee (as the "Post.Fem." marker) and the "Knee" marker (virtual). These non-collinear markers were used to define the thigh segment using CODA's software. Similarly, in the leg area, the three non-collinear markers used to define the leg segment were the "Ant.Tib." (virtual), the "Post.Tib." (virtual), and the ankle joint (virtual). The foot segment was also defined by the "Ankle" marker (virtual), "Heel" (real) and the "Toe" (real) marker.

Determination of knee joint centre of rotation is very important in all gait analysis studies. In this study, since the knee joint was covered by a brace or tape during the real test, placing a real marker on the lateral knee position was not possible and a virtual marker was constructed for this point. It was important to construct a "Virtual Knee" point exactly in the same position as it is normally placed in the standard marker set-up. To overcome this problem, when all markers were placed on the limb and just prior to applying the brace or tape, one additional real marker was placed on the lateral knee joint at the point where it is normally placed in CODA's standard marker set-up. Static data was then acquired showing the entire thigh and shank markers while the subject was in a standing position (midstance). The additional knee marker was then removed, the brace or tape was applied, and the test was carried out. During data processing this static knee point was used as a landmark to retrieve the virtual knee joint in the dynamic tests. The stick figures were used to match the real static and the virtual dynamic knee

positions with each other; thus the desired point of the centre of knee rotation was defined.

For confirmation of the technique, the trends of movements of virtual and real markers in the clusters were re-checked and complete consistency found between them in all trials.

3.14. Virtual Markers

A virtual marker is defined as a normalised linear combination of two or more position vectors (p) together with optional fixed offsets relative to the first three vectors. In other words, virtual markers are points in 3D space constructed by means of a fixed geometric relationship, from two or more points which may be either real markers or previously defined virtual markers (Figure 3-12). Virtual markers may be used to visualise and plot the movement of points which can not be tracked with real markers; they may be used to define centre of mass, or to facilitate the definition of vector angles. Their positions, velocities, and accelerations may be plotted graphically. A virtual marker may be thought of as an (offset) weighted average of the positions of a number of markers:

$$P_{vm} = W_1P_1 + W_2P_2 + W_3P_3 + L + X + W_4P_4 + \dots + W_nP_n$$

$$\text{Where } (W_1 + W_2 + W_3 + \dots + W_n) = 1$$

W = weight of the real markers; P = position vectors; V_m = Virtual Marker

Vector L is a fixed distance offset in a direction perpendicular to the line of the first two markers, towards the third. X is a fixed offset perpendicular to the plane defined by the first three markers. This scheme allows for a virtual marker to be located anywhere in space relative to three non-collinear points:

Figure 3-12: Non-collinear Markers [Charnwood Dynamics, (1996). CODA *mpx30* Manual, Page 48].

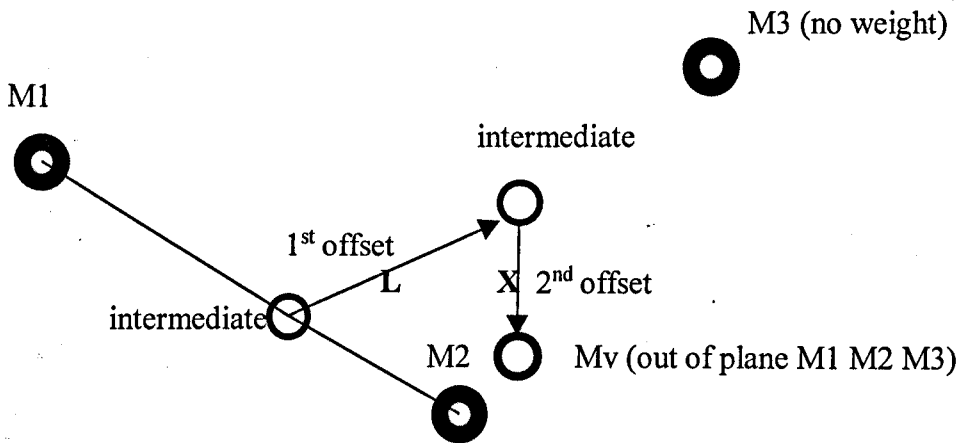

Note that the X offset remains valid only while M1, M2 and M3 remain non-collinear.

The Criteria for Validity of Virtual Markers Are as Following:

1. All the markers used to define a virtual marker must be in view;
2. The first three markers used to define 2D & 3D orthogonal constructions must be non-collinear;
3. Any component virtual markers must themselves be valid.

If any of these conditions are violated the virtual marker definition is rendered invalid.

3.15. Procedure of Calculation of the Tibial Translation in This Study (Virtual Marker Method)

An effort was made to calculate the translatory kinematics of the tibia relative to the femur in this non-invasive *in vivo* study. The literature review has revealed the difficulties regarding the calculation of the tibial translation, such as the lack of a point identifiable as the centre of knee rotation, and the combination of translatory and angulatory movements of the knee. Collaborating with Charnwood Dynamics software programmer, a new method was designed based on the capability of virtual markers in CODA *mpx30*.

Generally, a minimum grouping of 3 non-collinear markers attached to any segment allows that segment to be modelled as a rigid body having a local co-ordinate frame and local origin. The conversion from acquired marker (global) positions to rigid segmentation modelling is obtained by routine vector algebra, implemented in the Coda software by a variety of methods. The use of virtual markers facilitates modelling by

enabling the construction (by controlled vector operations) of rigid-model reference points in arbitrary positions which may be clinically relevant. In this case, virtual markers are constructed such that they coincide with real markers present during a static position capture – markers, which are subsequently removed for dynamic trials. The Motion Analysis software has been designed to avert catastrophic failure and so continually performs validity checks on the construction of virtual markers.

Thus, for dynamic trial data, the ‘missing markers’ are re-created by virtual marker modelling. The limb segment, thereby represented, allows the construction of a local (embedded) co-ordinate frame, using a Gram-Schmidt technique⁷. The global positions of markers placed on adjacent limb segments are then easily transformed into this local co-ordinate frame.

In the current study, the data were acquired in two static and dynamic situations. After placing the markers for the clustering method, four additional real markers were placed on the medial and lateral condyles of the femur and tibia and called “Med. Fem.”, “Lat. Fem.”, “Med. Tib.” and “Lat. Tib.”, respectively (Figure 3-13, left picture). Data were acquired with the subjects static, so that all of these markers were fully in view. These additional markers were then removed and the dynamic tests were carried out. In data processing, two static virtual markers were constructed at the distal end of the femur and the proximal end of the tibia from the markers located on the medial and lateral condyles of the femur and tibia. These were called Virtual Marker Femur (V.MF) and Virtual Marker Tibia (V.MT) representing two virtual points around the knee joint (Figure 3-13, middle picture). Then, the weighting of these markers were obtained from Coda’s software. These weights were transferred to the dynamic trial and the Dynamic Virtual Marker in Femur (DVM.F) and in tibia (DVM.T) were then defined. Using a macro formula designed by Charnwood Dynamics, and based on the techniques explained above, the sagittal (A-P translatory) movement of the tibial virtual marker (VM.T) relative to the femoral virtual marker (VM.F) was found during a gait cycle.

In Figure 3-13, the left picture shows the three non-collinear cluster markers on the thigh and shank and four markers on the medial and lateral surfaces of the femur and tibia (A-P view). The middle picture shows the virtual marker on the femur (VM.F) and virtual marker on the tibia (VM.T) that have been created using the weighted markers on the

⁷ The Gram-Schmidt orthogonalisation technique is a standard method of vector algebra, which constructs 3 mutually perpendicular unit vectors in relation to 3 original position vectors.

femur and tibia (lateral view). The right picture shows the femur as the “Local Origin” segment and the tibia in two different positions of “Heel strike” and “Toe off” in a gait cycle in which the tibia moves in an A-P and P-A directions. The “DVM.T1” shows the virtual tibial marker at heel strike and the “VM.T2” represents it at toe-off in the dynamic position. The length of the semicircular line between these two points was assumed as the A-P tibial translation in the stance phase.

As mentioned earlier, the current study is a comparative study and it was not an aim of this study to measure pure tibial translation. However, because the conditions were similar in any two groups in this study, this new method can be used to study the relative tibial translation. This allows comparison between ACL-deficient and control knees and comparison between ACL-deficient knees with different supports. Further explanation regarding this method and the pitfalls are provided in the “Discussion Chapter” (Chapter 6.1.3.).

Figure 3-13 Schematic Positions of the Real and Virtual Markers

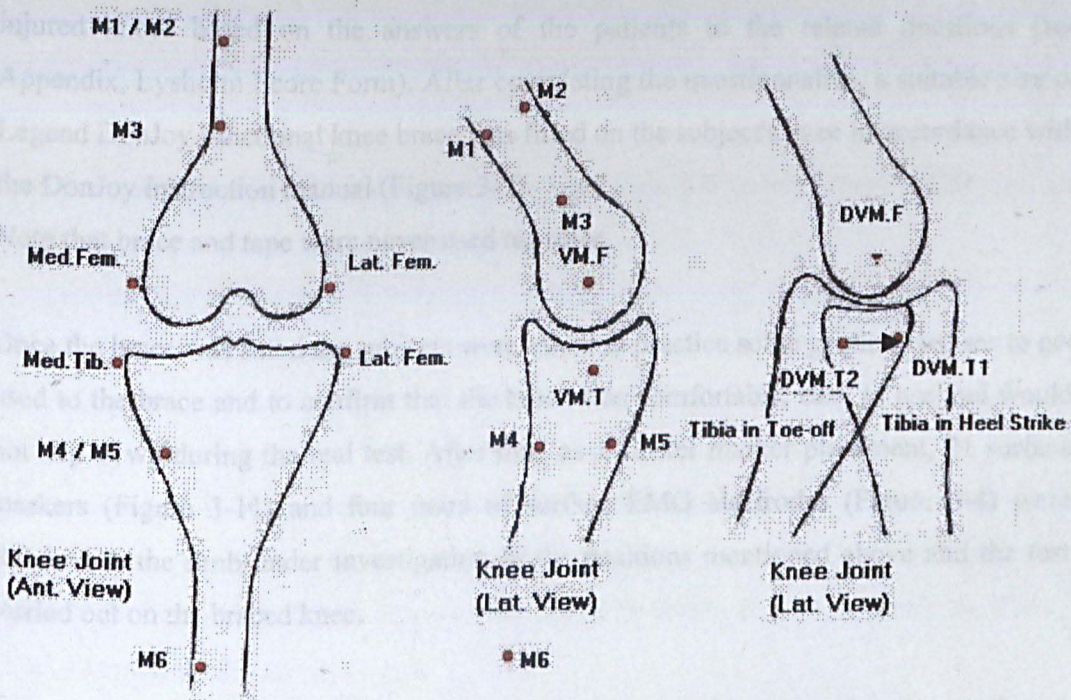

M= marker, Med.Fem. = Medial Femur, Lat.Fem.= Lateral Femur, Med.Tib.= Medial Tibia, DVM.F= Dynamic Virtual Marker Femur, VM.T= Virtual Marker Tibia, VM.T1=Virtual Marker Tibia in heel strike, DVM.T2= Dynamic Virtual Marker Tibia in toe-off.

3.16. Final Procedure for Recording

Each subject was seated on a comfortable stool and a detailed verbal explanation given. Then he (she) was asked to sign the consent form. The subjects were dressed in shorts so that the markers on the tested leg would be visible.

The subjects then completed a questionnaire providing their personal details and the history of their involvement in sport. Following this the anthropometric measurements, a manual muscle testing (MMT), range of motion (ROM), and the circumference of the thigh 15-cm above the mid-portion of the patella in the full-extended knee position, were recorded. Any deformities in the ankle, knee and hip joints were also checked for. These tests were carried out in both the ACL-deficient and control subjects.

Some questions regarding the date and mechanism of the injury, and the history of use of bracing / taping were asked of the ACL-deficient subjects, and the related parts of the questionnaire were completed.

The physical examination tests carried out by the author included the anterior drawer test in tibial neutral, internal and external rotation positions, and the Lachman, McMurray and collateral ligament integrity tests. Finally, the Lysholm Score was calculated for the injured knees based on the answers of the patients to the related questions (see Appendix, Lysholm Score Form). After completing the questionnaires, a suitable size of Legend DonJoy functional knee brace was fitted on the subject's knee in accordance with the DonJoy instruction manual (Figure 3-7).

Note that brace and tape were never used together.

Once the brace was fitted the subjects were asked to practice some gentle exercises to get used to the brace and to confirm that the brace was comfortable, easy to use and would not slip down during the real test. After that, as a cluster marker placement, 21 surface markers (Figure 3-11) and four pairs of surface EMG electrodes (Figure 3-4) were attached to the limb under investigation in the positions mentioned above and the test carried out on the braced knee.

The testing conditions included three levels: walking on level ground (at the preferred speed), walking on the treadmill (3.6 Km/hr) and running on the treadmill (10 Km/hr). Each subject was tested with the following supports in each of the test conditions:

- 1) With a FKB; 2) With a spiral method of taping; 3) Without any brace or tape.

Then, without removing or changing the places of any markers or EMG electrodes, the brace was gently removed and the test repeated in a without brace or tape condition. The

knee was then taped using the spiral method (Figure 3-9) and the subjects once again undertook the test.

Therefore, the study encompasses trials on the ACL-deficient and normal subjects, each with brace, without brace or tape, and with tape. Each test was carried out during walking on the level ground, walking on the treadmill and running on the treadmill.

Before commencing the tests, the subjects were asked to perform at least ten minutes of gentle exercise that was adapted to the test's environment.

To avoid bias the order of bracing and taping and the order of testing levels were randomly changed.

For each task the kinematic, force and EMG data of each subject was recorded. Each task was repeated more than once to have enough gait cycles for a complete analysis. For walking on level ground the test was repeated 3 times, and three full gait cycles were obtained. Two trials were recorded from the tests of walking and running on the treadmill. The tests on the treadmill lasted more than 5 minutes. After 2-3 minutes of walking or running, and when the speed was ideal and the subject had been adapted to the test, the recording systems (CODA *mpx30*, forceplate, and EMG instruments) were switched on and the trajectories of the markers were recorded for 5 seconds. For data processing three full gait cycles were derived from the tests of level walking on the treadmill, and five full gait cycles were derived from the tests of level running on the treadmill.

All efforts were made to teach the subjects to avoid targeting on the force plate to ensure their affected foot landed completely on the force platform.

To confirm that the subjects did not change their gait pattern, each walk was closely observed and all subjects were instructed to look straight ahead. The subjects were asked to walk at a comfortable walking speed on hearing the command "off you go", and were constantly observed to ensure that they walked with their usual gait pattern, especially when stepping on the force plate.

One complete gait cycle was recorded for each patient; from initial contact to the point where the same foot made contact with the floor again. A successful recording occurred when the complete gait cycle was captured by the CODA *mpx30* system and when the subject's foot had struck the force plate accurately. All marker and electrode placements

were routinely checked between the trials to ensure the researcher that they were in the right places.

An Acceptable Run Met the Following Requirements:

1. The leg being tested struck the force plate.
2. The other leg was outside the force plate.
3. No visible alteration in the gait pattern was noted during walking.

Following recording of the data it was computed immediately and checked to reassure the investigator that the recorded data was satisfactory and reliable.

3.17. Data Processing

Using CODA's instruction manual, the gait cycles were defined and the average for the gait cycles tested was obtained for each task for each subject. Generally, in gait analysis studies, when a task is carried out more than once and the investigator is provided with more than one gait cycle in each condition of a test, there are two methods to compare one condition with another. Some investigators choose the best gait cycle of each condition (representative cycle) and discard the other cycles. Others take an average of all recorded cycles in each task and obtain a mean gait cycle for each condition and then compare the means of the different conditions. In the current study we obtained three gait cycles for walking on level ground (3×1), six gait cycles for walking on the treadmill (2×3) and ten gait cycles for running on the treadmill (2×5). The author decided to get an average of the gait cycles in each condition to obtain a data representative of the real condition⁸. Finally, an appropriate statistical analysis was used to compare the derived data in the ACL-deficient and control groups.

It is important and relevant to note that since there was no force data available during level treadmill tests, only kinematic and EMG data were recorded for these trials. However, from the trials on level ground, all kinematic, kinetic and EMG data were obtained in this study.

Finally, using the Microsoft Excel programme, Microsoft Office 1997, the appropriate graphs were plotted.

⁸ To reduce the risk of error in having a mean gait cycle representative of the task, it is recommended to get as many gait cycles as is possible. In some circumstances, e.g. in standardisation of the force data in a specific group of people, it is highly recommended to get at least 6 trials (even 10 trials in some literature), to be able to obtain accurate average data (Munro *et al.* 1987).

3.18. Statistical Analysis Used in This Study

Four meetings were held with a statistical advisor of the Trent Institute, Faculty of Medicine and Health Sciences, University of Nottingham. We selected parametric statistics to compare the data of the patients with those of the control subjects. To understand the effect of bracing or taping (the supports) on the ACL-deficient knee, the non-braced normal subjects' data were selected as the control data. The non-braced ACL-deficient subjects' data was selected as the baseline data, and was compared with that of the control subjects to find the differences between the ACL-deficient and the healthy knees in terms of biomechanical variables.

The baseline data were also used to compare with that of the ACL-deficient knees following bracing or taping to determine the effects of the specific support. The "single factor ANOVA" (repeated measure) was chosen for comparison of the means of the specific parameters in different supports among the ACL-deficient subjects as a whole. In addition, the paired Student's *t*-test was used to make comparisons between the ACL-deficient knees with different supports, to find the effect of the support on the injured knee. A non-paired Student's *t*-test was also used to make comparison between the control group and each of the subgroups of the ACL-deficient subjects, to determine whether the specific support improved the injured knee towards the measurements made for the healthy knees (e.g. the braced ACL-deficient vs. controls).

3.19. Power Calculation

A statistical meeting was devoted to the "Power Calculation" of the study to determine the appropriate sample size. The study is a "Prospective Experimental Case-Control Study".

Since the number of ACL-deficient patients was very low in the pilot study and the calculated A-P translation was not pure A-P tibial displacement, the mean and standard deviation of the A-P tibial displacement in normal and ACL-deficient knees was obtained from the literature, and was used as a key factor to conclude required sample size for this study. The statistics formula for the required sample size in our study is as follows (Kirkwood, 1988):

$$N > \frac{(u + v)^2 (\sigma_1^2 + \sigma_2^2)}{(\mu_1 - \mu_2)^2}$$

Where:

$\mu_1 - \mu_2$ = Differences between the means (in my study 2 mm A-P tibial translation difference between the normal and ACL-deficient knees)

σ_1, σ_2 = Standard deviations

u = one-sided percentage point of the normal distribution corresponding to 100% - the power, e.g. in this study, power = 95%. (100% - power) = β = 5% and $u = 1.64$

v = percentage of the normal distribution corresponding to the required (two - sided) significance level, e.g. in this study the significance level = α = 5%, $v = 1.96$.

In the literature (Karrholm (1989), Nordt et al (1999), Viola et al (1999) and Ganko et al (2000) a 3-mm mean A-P tibial displacement difference has been selected as the standard difference between normal and ACL-deficient knees. However, for greater accuracy, and due to a larger sample size, a 2-mm mean difference was chosen in our study. The average standard deviations are different in the literature for the normal and ACL-deficient knee. Having averaged the SD of the tibial displacement following a study of the literature, a 0.67 and 1.67 for normal and ACL-deficient knees were found respectively.

$$N > \frac{(1.64+1.96)^2 (0.45+2.79)}{(2)^2} = \frac{42}{4} = 10.5$$

Conclusion

In this study, at least 11 subjects were needed in each group (experimental or control group) to have a power of 95% (β) and a significant level of 5% (α).

It is important to note that if the required difference between two means increases to 3 mm (instead of 2 mm), the required sample size reduces to 5 patients.

In brief, based upon the data from the literature, it is estimated that 11 subjects will be required assuming $\alpha = 0.05$ and $\beta = 0.95$. The data collected from the tests was analysed using parametric statistics on a PC using Microsoft Excel, Microsoft Office 1997.

3.20. Summary of Methodology of the Research

To evaluate the biomechanical changes in the knee joint following ACL-deficiency, and to assess the effects of either functional knee bracing or a spiral method of taping on the tibio-femoral joint, a multidisciplinary study was conducted. After obtaining Ethical Committee approval, and according to the specific inclusion and exclusion criteria, 15 unilateral ACL-deficient subjects as the experimental, and 15 matched healthy subjects as the control groups, were selected.

A CODA *mpx30* motion analysis system, a force plate and a Telemetry EMG system were used to assess the kinematic, kinetic and EMG parameters of the ankle, knee and hip joints, in the ACL-deficient and control subjects. The tests were carried out in three conditions, each with three different support situations for the knee. The subjects underwent the tests while wearing a Legend DonJoy FKB, with a spiral method of taping, and without the brace or taping. With each support, the subjects were tested during simple walking, walking on the treadmill and running on the treadmill; and the biomechanical data including kinematics, kinetics and EMG were recorded and compared between the experimental and control groups. The repeated measures single factor ANOVA and the Student *t*-tests were used in statistical analysis comparing the ACL-deficient groups with different supports and comparing the ACL-deficient and control groups. The final results were illustrated both numerically and graphically.

Figure 3-1 CODA-3 (The Old Version of CODA *mpx30*)

[From: Bartlett. Introduction to Sports Biomechanics, 1997 Page 260].

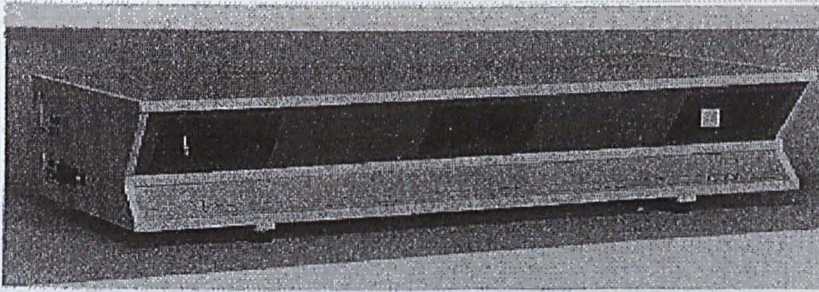

Figure 3.2 CODA *mpx30* Scanner Unit

The unilateral CODA *mpx30* used in this study.

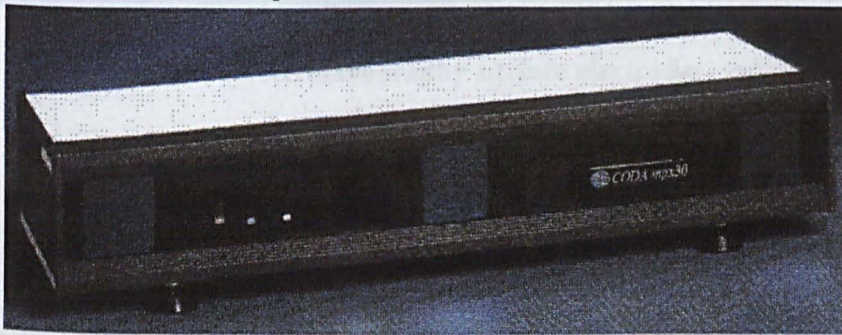
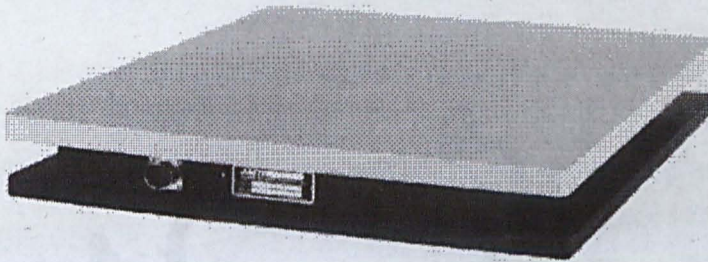
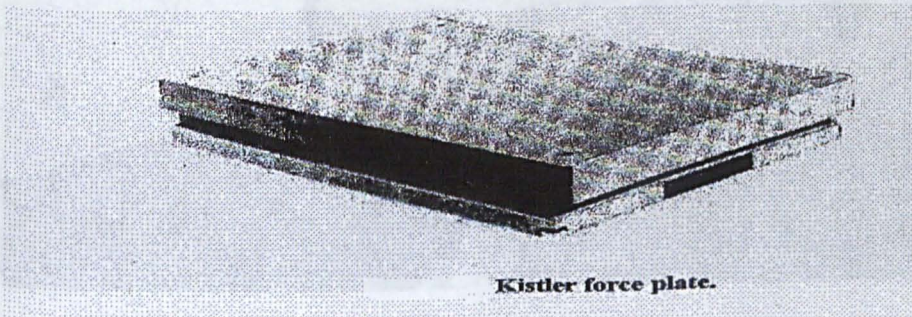

Figure 3.3 Two Types Force Platforms Used in This Study.



AMTI forceplate



Kistler force plate.

Kistler forceplate

Figure 3-4 Electromyography Surface Electrodes & Transmitter Pack.
[Telemetered Chamwood Dynamic Electromyography (EMG) System].

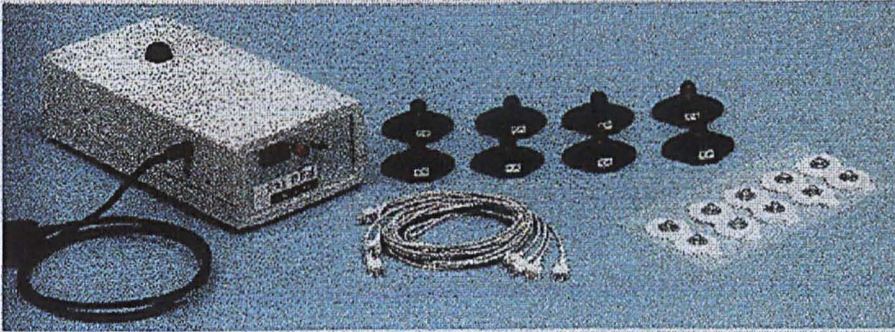

Electromyography surface electrodes and transmitter pack.

Figure 3-5 Treadmill Used in This Study.

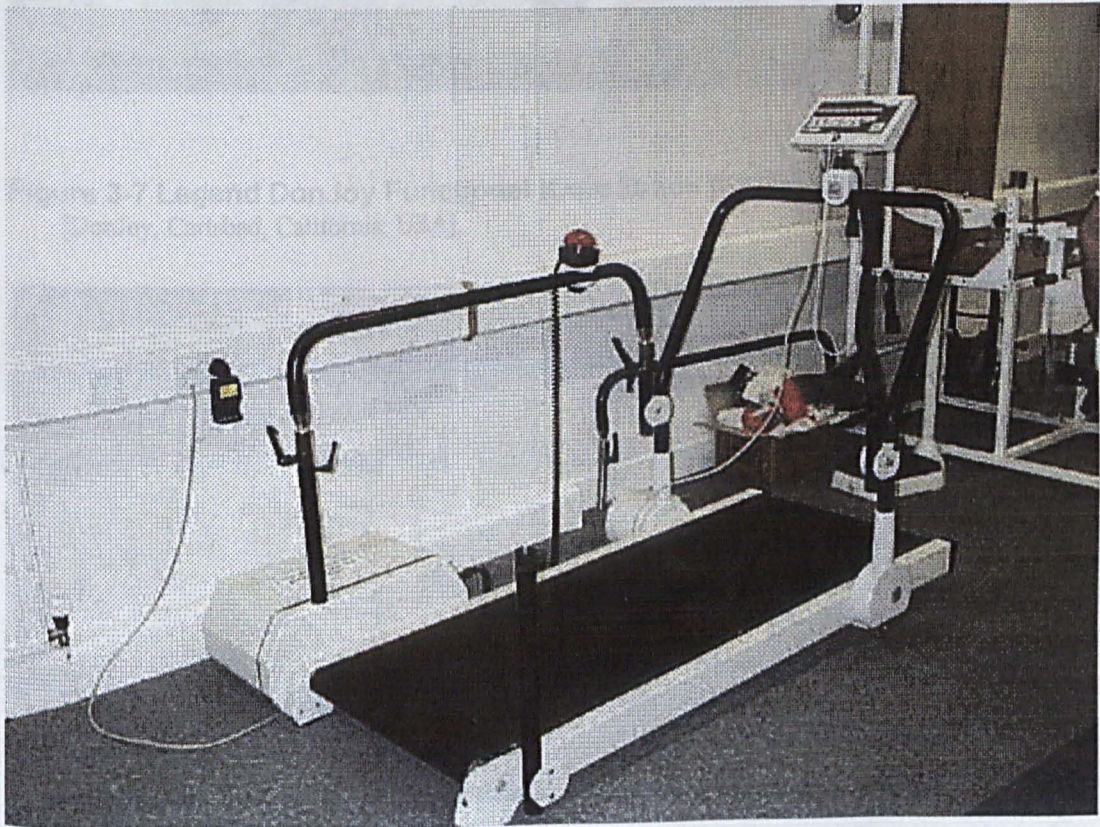

Figure 3-6 Drive Boxes and LED Markers Used in This Study.

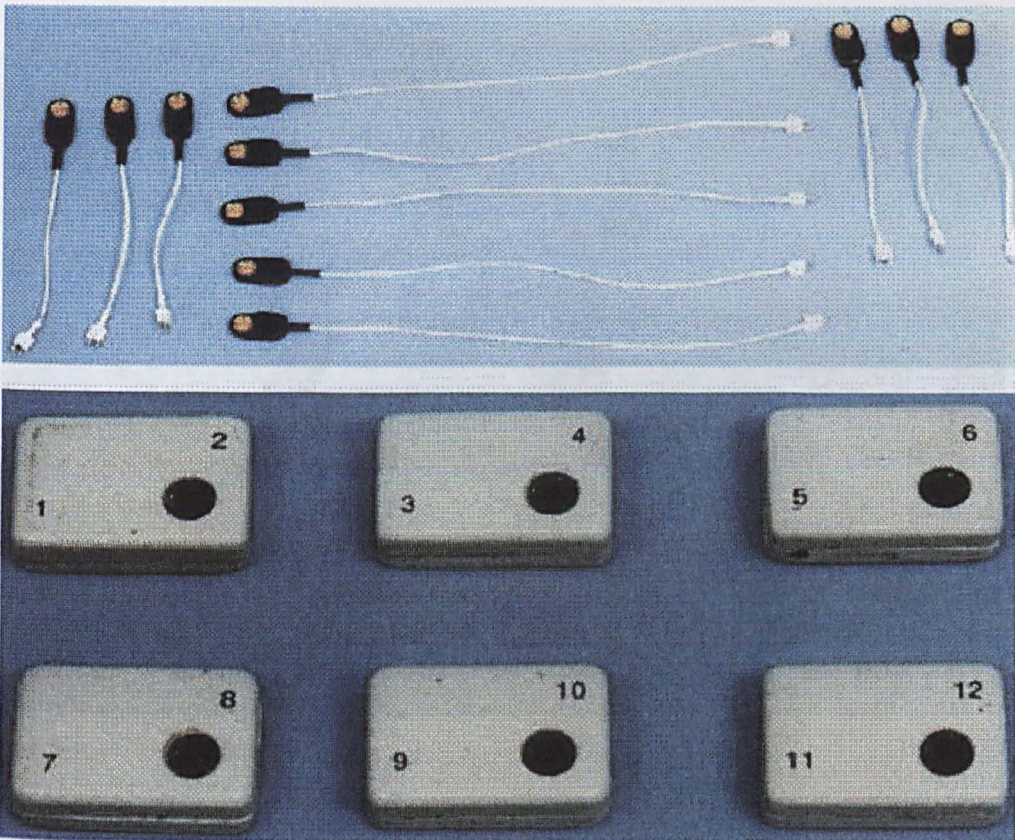

Figure 3-7 Legend DonJoy Functional Knee Brace (FKB) Used in This Study.
[DonJoy, Carlsbad, California, USA].

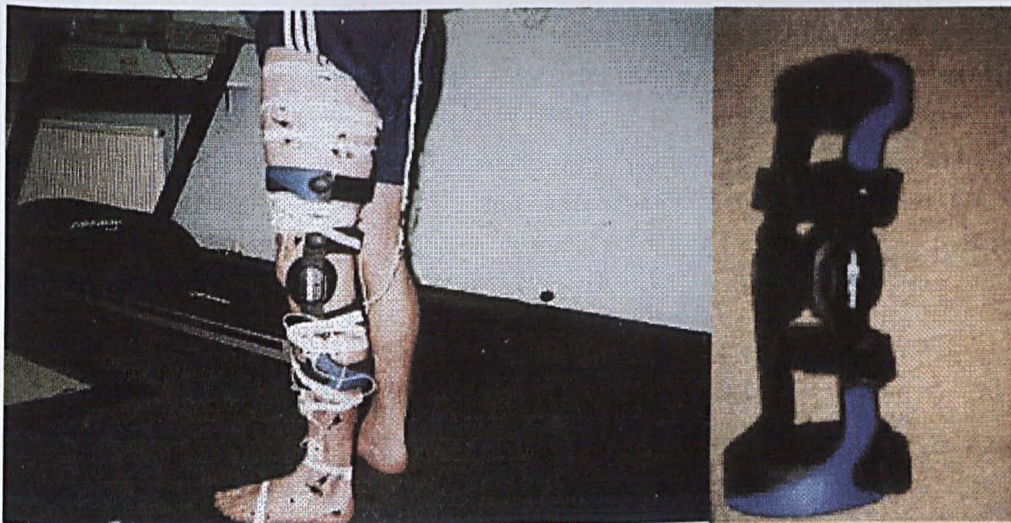

Figure 3-8 Running on the treadmill with taped ACL-deficient knee.



From Walsh K.J. and W.R. Winters. "The Comprehensive Manual of Taping and Wrapping Techniques". The University of Kansas published by Carter products, Inc. 1991 Carter, Kansas 66230 USA. 3-15-91

Figure 3-9 Five Stages of Taping Used in This Study.



(1)

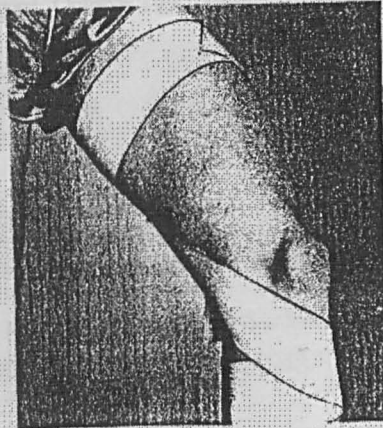

(2)



(3)

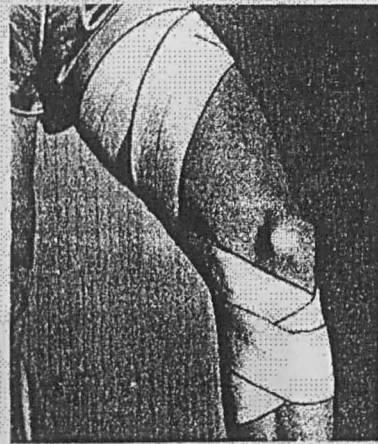

(4)



(5)

From: Writh K.E and W.R Whitehill: "The Comprehensive Manual of Taping and Wrapping Techniques". The University of Alabama published by Cramer products, Inc. 1991 Cardner, Kansas 66030 USA: 2-55-6

Figure 3-10 Coda's Unilateral Standard Marker Placement.[From: Charnwood Dynamics, CODA *mpx30* Motion Analysis, October 1999, Page 31].

Figure 3-11 Schematic Figure of the Clustering Marker Placement Method Used in This Study



Schematic Figure of the Cluster Marker Placement Used in This Study.

CHAPTER FOUR - PILOT STUDY

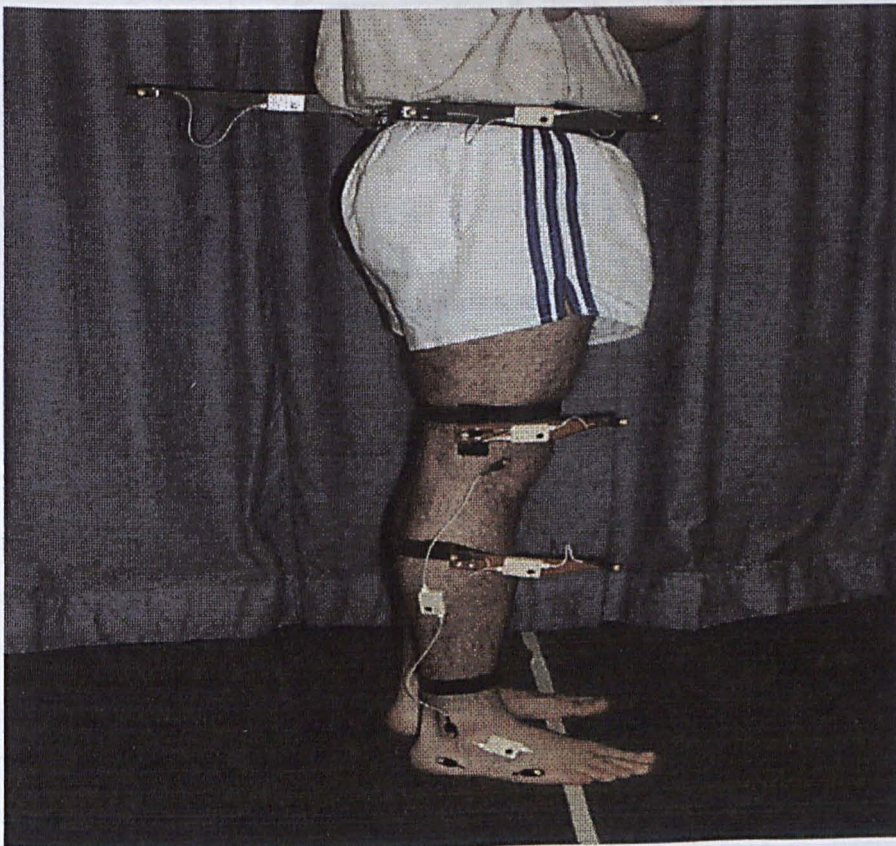
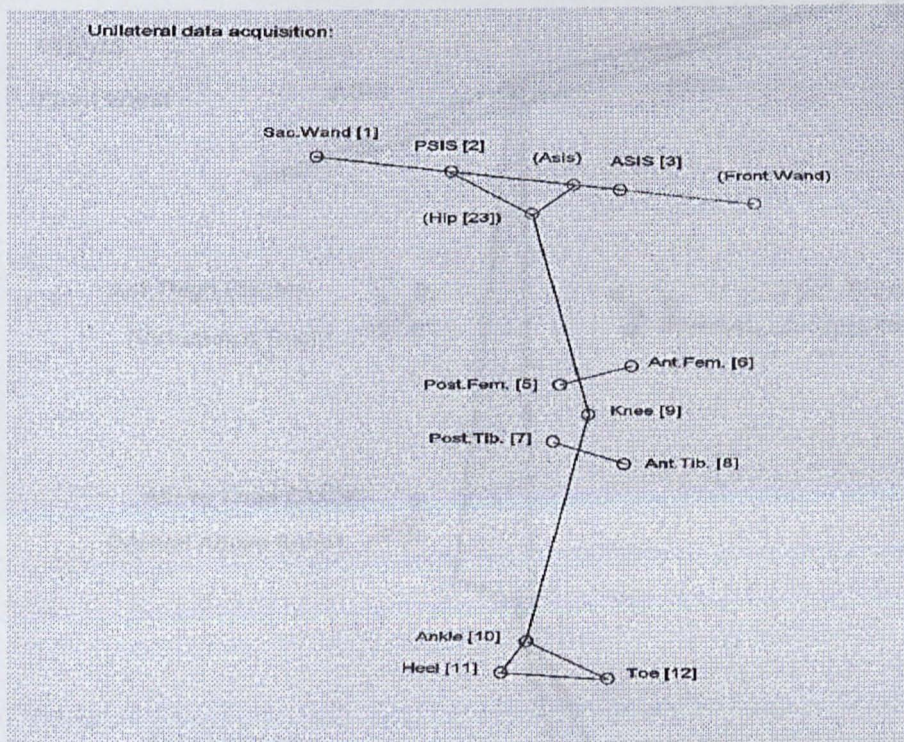
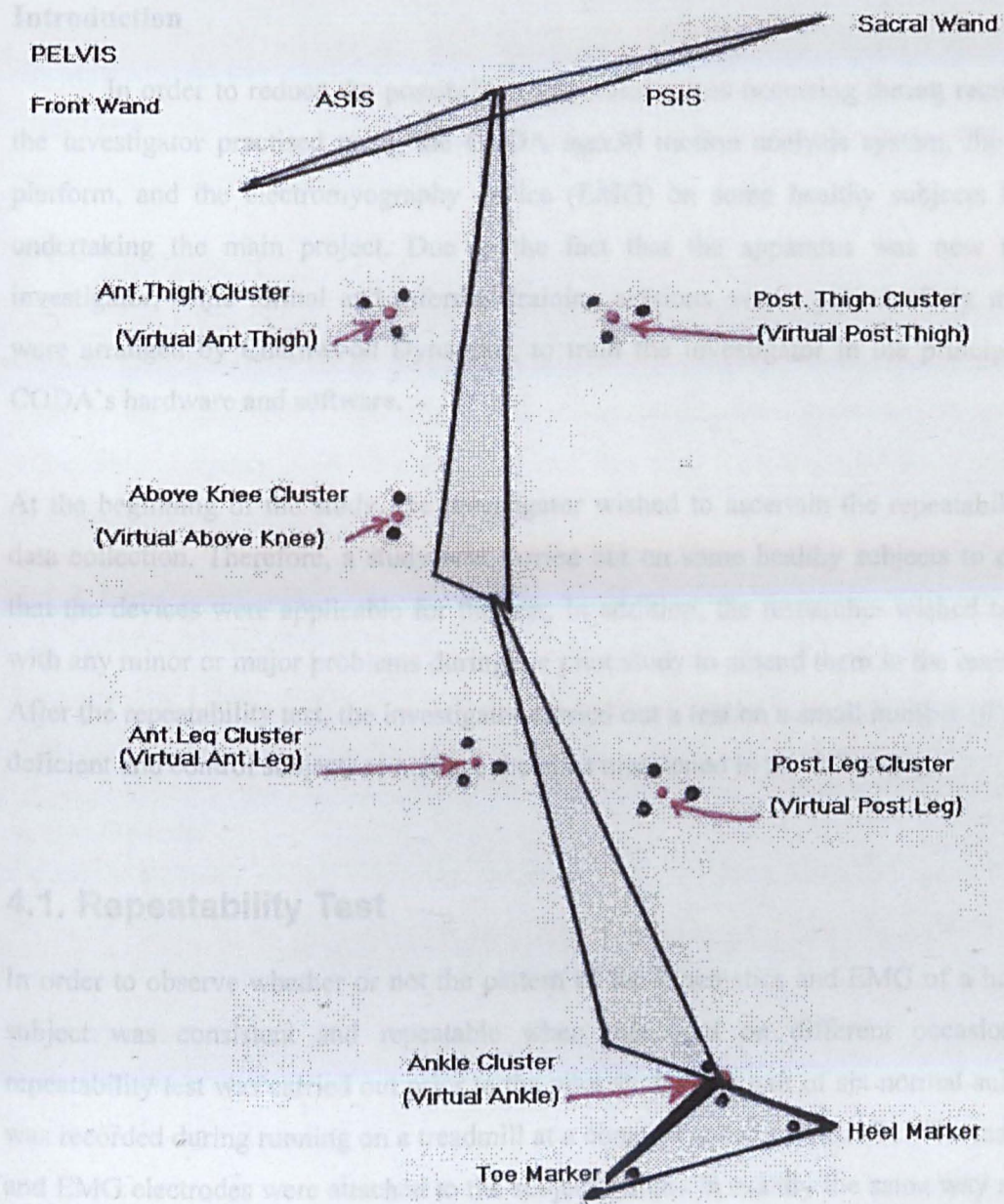
Introduction

In order to reduce the possibility of operator errors occurring during recording, the investigator practised using the CODA *mpx30* motion analysis system, the force platform, and the electromyography device (EMG) on some healthy subjects before undertaking the main project. Due to the fact that the apparatus was new to the investigator, some formal and informal training sessions over a period of six months were arranged by Charnwood Dynamics, to train the investigator in the principles of CODA's hardware and software.

At the beginning of the study, the investigator wished to ascertain the repeatability of data collection. Therefore, a study was carried out on some healthy subjects to ensure that the devices were applicable for the test. In addition, the researcher wished to deal with any minor or major problems during the pilot study to amend them in the main test. After the repeatability test, the investigator carried out a test on a small number of ACL-deficient and control subjects to achieve the aims mentioned in the following.

4.1. Repeatability Test

In order to observe whether or not the pattern of the kinematics and EMG of a healthy subject was consistent and repeatable when measured on different occasions, a repeatability test was carried out prior to the pilot study. The gait of six normal subjects was recorded during running on a treadmill at a constant speed of 9 Km/hr. The markers and EMG electrodes were attached to the subjects' limbs in exactly the same way as the real test (Figure 3-11). The test was carried out only in the braced normal subjects during running on the treadmill. The subjects completed two trials on three separate occasions: two on the same day (morning and afternoon) and one a week later. Two full independent gait cycles were randomly chosen from each trial. The ankle, knee and hip joints angles and the Peak & RMS variables of the EMG of two gait cycles of each subject were compared during trials 1 and 2 of the first, second and third occasions. Data processing was carried out in exactly the same way as the real tests and the results were analysed.

4.1.1. Aims

The aim of this part of the study was to see if there are any significant differences between the gait cycle variables within the trials of each subject in a session or between the trials of a subject at the same day or between a day and a week later. The hypothesis was that no significant differences should be seen between the two gait cycles in in morning and afternoon sessions of the same day and a week later.

4.1.2. Equipment

A unilateral Coda *mpx30* and a Telemetered EMG system located in the Movement Laboratory of the Division of Orthopaedic & Accident Surgery, QMC, Nottingham, was used in the repeatability test. All pieces of equipment were interfaced to an IBM compatible computer. A 200 Hz sampling rate was used for kinematics and EMG data recording.

4.1.3. Data Analysis

Having been advised by Dr. Duvey, a statistician in the Trent Institute, Faculty of Medicine and Health Sciences, University of Nottingham, repeated measures ANOVA were used for statistical analysis.

4.1.4. Results

Summary statistics of the kinematic parameters of 6 normal subjects comparing the recorded values on the three occasions are given in Table 4-1. Either the P-value or the Intra-class Correlation Coefficient (ICC) results showed no statistically significant differences between the first, second and third recordings with respect to the angles or EMG variables of the ankle, knee and hip joints. A p-value of 0.05 was regarded as the threshold for significance.

This test confirmed the intra-day and inter-days repeatability of the kinematics and EMG studies on the ankle, knee and hip joints. The results suggested that the measurements of lower limb joint positions and myoelectric activities can be reliably obtained by the same observer on separate occasions using the Coda *mpx30* system (Figure 3-2) and the Telemetered EMG system (Figure 3-4). These results have graphically been shown in Figure 4-1.

Table 4-1 Results of the Repeatability Test.

Gait Parameters (n = 6)		Occasion 1 ¹		Occasion 2 ²		Occasion 3 ³		P- value ⁴
		Trial 1	Trial 2	Trial 1	Trial 2	Trial 1	Trial 2	
Max. Ankle P.F. (Swing)	Mean	-16	-11.6	-16.7	-16.9	-15.3	-6.7	0.570
	SD	8.8	13	7.2	7.9	8.3	17.9	
Max. knee flexion (Swing)	Mean	49.9	51.5	53	53.3	49.5	51.3	0.805
	SD	5.3	5.1	5.8	6	4.8	6.1	
Max. Hip extension (Stance)	Mean	1.2	1.3	0.7	1.7	2	-1	0.995
	SD	10.2	8.8	8.9	8	9.5	10.8	

Key: Max = maximum, ¹Occasion 1 = Morning session test, ²Occasion 2 = Afternoon session test, ³Occasion 3 = A week after test, ⁴P value = ANOVA (repeated measured), Max.=maximum, P.F.= plantar flexion.

The Intra-class Correlation Coefficient (ICC) analysis was also calculated and the results have been shown in Table 4-2.

Table 4-2 Results of Intra-Class Correlation Coefficient Tests on Six Braced Normal Subjects during Running on the Treadmill

Intra-Class Coefficient Variation Results "Between Days".			
	Single Measure		Average Measure
Knee	0.9861		0.9428
Ankle	0.6374		0.8406
Hip	0.9569		0.9852
Intra-class Correlation Coefficient Results "Within Days".			
		Single Measure	Average Measure
Knee	Occasion 1	0.8967	0.9455
	Occasion 2	0.9763	0.988
	Occasion 3	0.7664	0.8678
Ankle	Occasion 1	0.7191	0.8366
	Occasion 2	0.9785	0.9861
	Occasion 3	0.5063	0.6722
Hip	Occasion 1	0.9765	0.9881
	Occasion 2	0.9856	0.9927
	Occasion 3	0.9825	0.991

Occasion1 = morning, Occasion2 = afternoon, Occasion3 = a week later.

The Intra-class Correlation Coefficient (ICC) analyses for the "Between Days" and "Within Days" tests were carried out to support our *P values*. In interpretation of the ICC results, the following categorisation was found in the literature (Cornwall & McPoil, 2000). Any ICC less than 0.2 is defined as "Poor", between 0.2 and 0.4 is "Fair", between 0.4 and 0.6 is "Moderate", between 0.6 and 0.8 is "Substantial" and between 0.8 and 1 is known as "Almost Perfect". The literature also suggested that an ICC value at

least 0.75 is needed to indicate reliability. The results of our ICC showed that approximately all variables of the tested joints had an ICC between 0.8 and 1 and thus categorised as "Almost Perfect". Therefore, with the single measure and average measure ICC results, we can conclude that no significant differences exist either between the occasions (between days) or within an occasion (between two trials in a day) in the current study. Table 4-2 shows the full results of ICC test in this study.

The repeatability of the EMG pattern during running on the treadmill at a constant speed of 9 Km/hr was also checked by the ICC tests. Inter-individual variability could be due to factors such as skin resistance, thickness of subcutaneous fat, and variability in placement of the surface electrodes. The results indicated that EMG patterns were also reasonably consistent for a given subject and indicated that it can be reliably obtained by the same observer on separate occasions.

Figure 4-1 Histograms of the "Repeatability Test" With Coda *mpx30* Gait Analysis.

The Repeatability Test - Knee Flexion

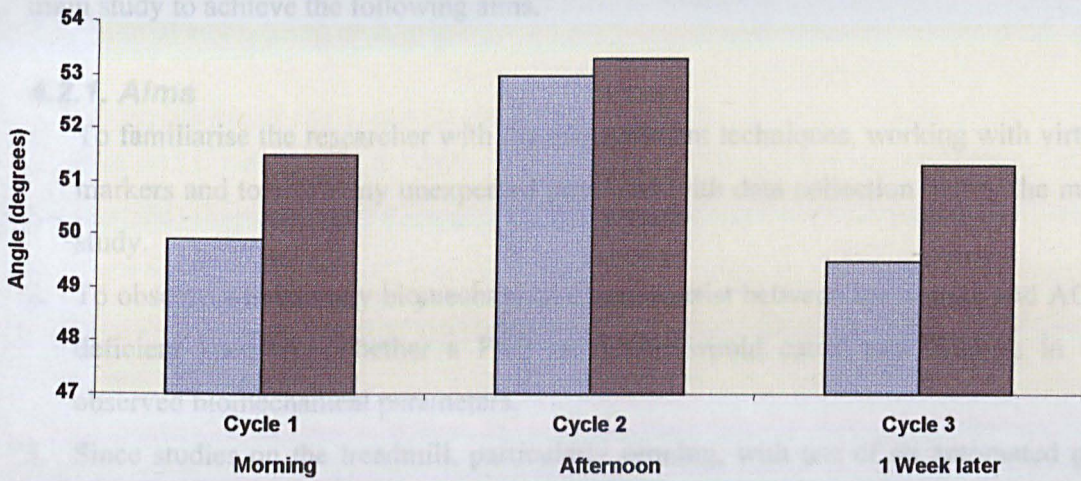

The Repeatability Test - Ankle Plantar Flexion

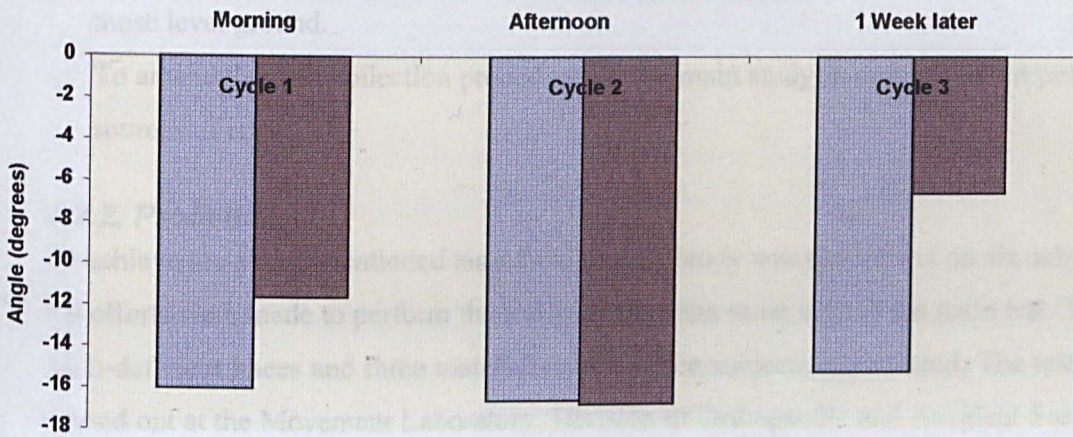

The Repeatability Test - Hip Extension

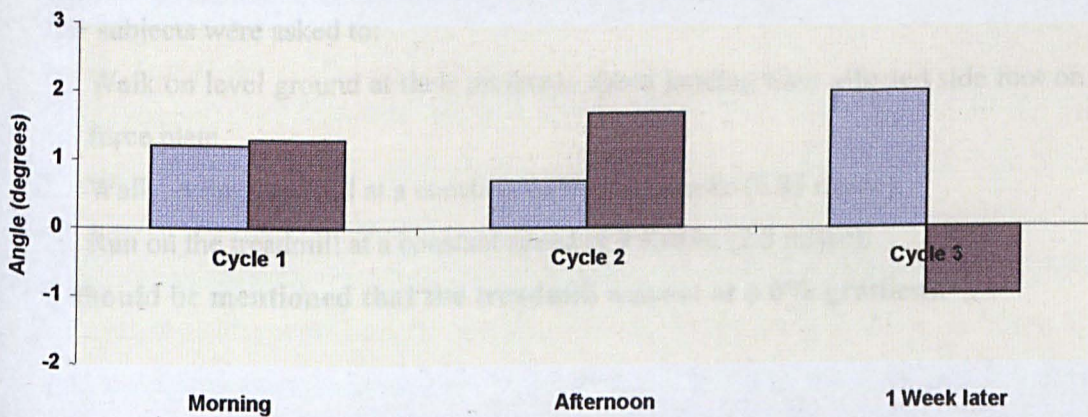

4.2. Pilot Study

After successfully testing the repeatability of the equipment, the investigator carried out a real study on small numbers of ACL-deficient subjects and control subjects prior to the main study to achieve the following aims.

4.2.1. Aims

1. To familiarise the researcher with the measurement techniques, working with virtual markers and to solve any unexpected problems with data collection before the main study.
2. To observe whether any biomechanical changes exist between the normal and ACL-deficient knee and whether a FKB or taping would cause any changes in the observed biomechanical parameters.
3. Since studies on the treadmill, particularly running, with use of an automated gait analysis system has rarely been carried out, the researcher wished to ensure that the gait cycles derived from trials on the treadmill are as feasible and reproducible as those level ground.
4. To amend the data collection procedures in the main study in order to avoid possible sources of error.

4.2.2. Procedure

To achieve the above-mentioned aims fully, a pilot study was carried out on six subjects. All efforts were made to perform the test in exactly the same way as the main test. Three ACL-deficient knees and three matched-normal knee subjects were tested. The test was carried out at the Movement Laboratory, Division of Orthopaedic and Accident Surgery, Queen's Medical Centre, Nottingham University, Nottingham, UK.

4.2.3. Test Modes

The subjects were asked to:

1. Walk on level ground at their preferred speed landing their affected side foot on the force plate.
2. Walk on the treadmill at a constant speed of 3 Km/hr (0.83 m/sec);
3. Run on the treadmill at a constant speed of 9 Km/hr (2.5 m/sec).

It should be mentioned that the treadmill was set at a 0% gradient.

Each subject was tested bare footed with the following supports:

1. With a DonJoy functional knee brace (FKB) (Figure 3-7).
2. With a spiral method of taping (Figure 3-8).
3. Without any bracing or taping.

4.2.4. Equipment for Data Collection

A unilateral Coda *mpx30*, a Kistler 9261 A force plate (Kistler Instruments Limited, Switzerland) (Figure 3.3) of dimensions 600 mm × 400 mm, and thickness 60 mm, and a Telemetered EMG system, all interfaced to an IBM computer located in the Movement Laboratory of the Division of Orthopaedic & Accident Surgery, QMC, Nottingham, were used in the pilot study.

The kinematic data was collected by a Coda gait analysis system (Coda *mpx 30*, Charnwood Dynamics Ltd, UK) (Figure 3-2) with a 200 Hz sampling frequency. Using the clustering marker placement method which was explained in 3.6.1 (Figure 3-11), twenty-one active infrared markers were directly mounted onto the skin of the lower extremity of the subjects and the trajectories of the markers were recorded by the Coda gait analysis system.

The force plate (Figure 3-12) was set into a 9-m indoor walkway and a 200 Hz sampling frequency was used. A Telemetered EMG (Figure 3-4), Charnwood Dynamics, UK, with a sampling rate of 200 Hz simultaneously with the Coda system and the force plate recorded the EMG activities of four muscles around the knee joint. A motorised treadmill (Figure 3-5) was also used in this study to provide a constant speed. To avoid obscuring the recording view, the stands of the treadmill were removed during data acquisition.

4.3. Patients' Screening

4.3.1. Subjects Characteristics

Ten unilateral ACL-deficient subjects were chosen from a waiting list of the ACL-deficient subjects in the Orthopaedic Outpatient Clinic, Queen's Medical Centre, University Hospital, Nottingham, UK. The subjects were selected based on the inclusion and exclusion criteria stated in Chapter 3. Ten letters with the signature of Mr. Forster, Consultant Orthopaedic Surgeon and the Clinical Director of the study were sent to the subjects asking them to participate in the study, if they wished. A subject information sheet, a consent form, and a copy of the project understandable for lay persons was also sent to the subjects. Out of ten selected ACL-deficient subjects, only four subjects

replied and agreed to take part in the study and were tested. After the test, one subject was reported (by the clinical director) to be misdiagnosed as he had a medial meniscus injury instead of ACL-deficiency. This subject was also excluded from the study. Therefore, the pilot study consisted of three unilateral ACL-deficient subjects as the experimental and three matched healthy subjects as the control group. The subjects included two males and one female in each group. Two of the ACL-deficient subjects had been arthroscopically confirmed and the other one had MRI diagnosis. (Table 4-2).

The subjects sustained the injury within the last 7.5 years. Table 4-3 shows the subjects characteristic profile.

All volunteers were provided with a written informed consent form in accordance with the guidelines established by the Ethics and Approval Committee of the University of Nottingham.

All subjects' screening requirements were carried out in a similar way to as explained in 3.8.

Table 4-3 Results of Subjects' Examination Tests (in Pilot Study).

ACL-deficient subjects characteristics	Injury	Diagnosed by (before surgery)	Combined injury with ACL	History of using brace
Subject 1	ACL	Arthroscopy	Nothing	No
Subject 2	ACL	Arthroscopy & MRI	Nothing	No
Subject 3	ACL	MRI	Nothing	No

ACL-deficient subjects	Physical Examination Tests (By Abbas Rahimi)			Lysholm Score (%)
	Ant. Drawer Test	Lachman Test	McMurray Test	
Subject 1	+	+	-	81 (Fair)
Subject 2	+	+	+	43 (Poor)
Subject 3	+	+	+	74 (Fair)

NB: Normal subjects had no history of injury on their lower limbs affecting their gait

According to the manual instruction of the Brace Company, a DonJoy FKB was fitted on the subject's knee by the researcher. Twenty-one surface markers and four pairs of surface EMG electrodes were also attached to the tested limb as described in Chapter 3 and the test was carried out on the braced knee. Without removing the markers or EMG electrodes, the brace was gently removed and the knee was taped using the procedure stated in 3.9.6.1. The test was repeated on the taped knee. Thereafter, the tape was

removed without removing or changing the places of the markers of CODA or the EMG electrodes and the test was carried out without brace or tape. To reduce the risk of bias, the order of bracing or taping was randomly changed.

For each task, the kinematics, kinetics and EMG data of the subjects was recorded while with brace, or without brace and with tape. Each test was repeated while walking on level ground, walking on the treadmill and running on the treadmill.

Table 4-4 Characteristics of the Subjects Participating in the Pilot Study.

Subjects Characteristics	ACL-deficient knee			Normal		
	Numbers	3			3	
Tested Side	Rt., Lt, Lt			Rt., Lt, Lt		
Sex	F, M, M			F, M, M		
Age (yr.)	32, 34, 40 [35.3+/-4.2*]			32, 33, 35 [33.3+/-1.2]		
Height (m)	1.74, 1.75, 1.71 [1.73+/-0.02]			1.75, 1.56, 1.75 [1.69+/-0.09]		
Mass (Kg)	91.2 (+/-15.7)			75.2 (+/-12)		
Dominant Leg	Rt.			Rt.		
Speed of walking on the ground (m / Sec.)	Brace	No B/T	Tape	Brace	No B/T	Tape
	1.2 (0.09)	1.2 (0.06)	1.15 (0.03)	1.19 (0.17)	1.07 (0.08)	1.12 (0.1)
Speed of walking on the treadmill	3 Km /hr (0.83 m/Sec)			3Km/hr (0.83 m/Sec)		
Speed of running on the treadmill	9 Km /hr (2.5 m/Sec)			9 Km /hr (2.5 m/Sec)		
Years Passed Injury	3.2 (2) ranges 1.5 - 5.5			-		

* Data after +/- is SD.

*Training Status	ACL-deficient knee	Normal
Subject 1	↑ than 7.5 years - Amateur	↑ than 7.5 years - Amateur
Subject 2	2.5 - 7.5 years - Amateur	2.5 - 7.5 years - Amateur
Subject 3	↑ than 7.5 years - Amateur	↑ than 7.5 years - Amateur

*Number of years training usually twice per week.

4.4. Results

The observed changes in the biomechanics between the normal and ACL-deficient subjects with and without bracing or taping in different test modes convinced the investigator to proceed with the main study with reasonable confidence in the protocol. The pilot study also convinced the investigators that the main pieces of equipment for the tests are suitable, although some amendments were needed (Rahimi & Wallace, 2000b). The graphs of the trials on the treadmill ensured the investigator that the results were very consistent either in kinematics or in EMG data. The investigator achieved all the planned aims mentioned in 4.2.1.

Figure 4-2 shows a sample of consistent recorded kinematic and EMG data during running on the treadmill in the pilot study. Since the numbers of subjects were small in each group, no statistical analysis was performed on the results of the pilot study.

Overall, carrying out the pilot study provided an excellent opportunity for the investigator to face all unexpected major and minor practical problems that might happen in the main study. The following amendments were gained as an outcome of the pilot study.

4.5. Amendments to the Main Study

In order to achieve better results the following changes were applied to the main test in which a larger number of subjects were studied.

1. To have a walking speed closer to that on the ground, it was decided the speed of walking on the treadmill to be increased from 3 Km/hr (0.83 m/sec) to 3.6 Km/hr (1 m/sec).
2. The speed of running on the treadmill should also be increased from 9 Km/hr (2.5 /sec) to 10 Km/hr (2.8 m/sec) to have a more forceful physical activity.
3. To obtain more gait cycles and to have a more accurate average of the cycles of each trial, it was decided that the number of trials on level ground should be increased to three trials. The number of trails of walking on the treadmill should be increased to 2 (each with 3 gait cycles); and running on the treadmill should also be increased to 2 trials (each with 5 gait cycles). In other words, in the main study, three gait cycles (3×1) from the tests of walking on level ground, six gait cycles (2×3) from walking on the treadmill and ten gait cycles (2×5) from running on the treadmill in each testing situation will be available.
4. To achieve walking in a more normal style, the walkway of the laboratory should be increased to at least 12 meters and the subjects would be asked to start walking at least two meters before being viewed by the CODA machine.
5. Before commencing the tests with each support, the subjects would be asked to practice walking and running as much as they can to accommodate themselves with the test's environment.
6. To avoid targeting walking, it was decided to cover the force platform with the same material as the rest of the floor. In addition, the subject's awareness of the plate was minimised by focusing their attention on the far wall.
7. To save time in obtaining an average gait cycle in different trials, the Charnwood Dynamics' mathematical software engineer was asked to provide the Coda software with

a new facility to enable the researcher to obtain the desired epochs from each gait cycle automatically.

Having carried out the pilot study, the Movement Laboratory of the Division of Orthopaedic and Accident Surgery was transferred from the Queen's Medical Centre to Nottingham City Hospital. Fortunately, the new gait lab had more facilities and therefore problems number 4 and 6 had already been resolved. The new movement laboratory has a 16-meter walkway with two AMTI force platforms covered with the same material as the floor. The engineer also provided the investigator with the desired software thus the required number of epochs (usually 100 epochs) in each trial could be obtained easier.

4.6. Summary of the Pilot Study

The intra-day and inter-days repeatability of the CODA *mpx30* and the Telemetered EMG were tested in six braced normal subjects during running on the treadmill. The results of the repeatability test showed no significant difference in range of motion of the ankle, knee and hip joints either within or between the trials in the same day or a week later and confirmed the repeatability of the recording systems. A pilot study was also performed on three ACL-deficient subjects and three carefully matched healthy subjects prior to the experimental study to familiarise the researcher with the measurement techniques to be adopted in the main study. The other aims of the pilot study were to determine if any observable biomechanical changes existed between the normal and ACL-deficient knees and whether a FKB would cause any changes in the recorded parameters.

The pilot test ensured the investigator of the suitability of the CODA *mpx-30* system and that the system will generate the automatic report of the kinematic and EMG data for the trials on the treadmill as well as kinematic, kinetic and EMG data for the trials on level ground. The pilot study also showed that the tests on the treadmill are very consistent and reproducible. Carrying out a pilot study on real subjects provided a very good opportunity to the investigator to be able to resolve any difficulties that might be faced during the main study. It was concluded that the study should be extended to a larger group of subjects to show the details of the effects of bracing or taping on ACL-deficient knees.

Figure 4-2 Consistency of the Kinematic and EMG Data during Running on the Treadmill.

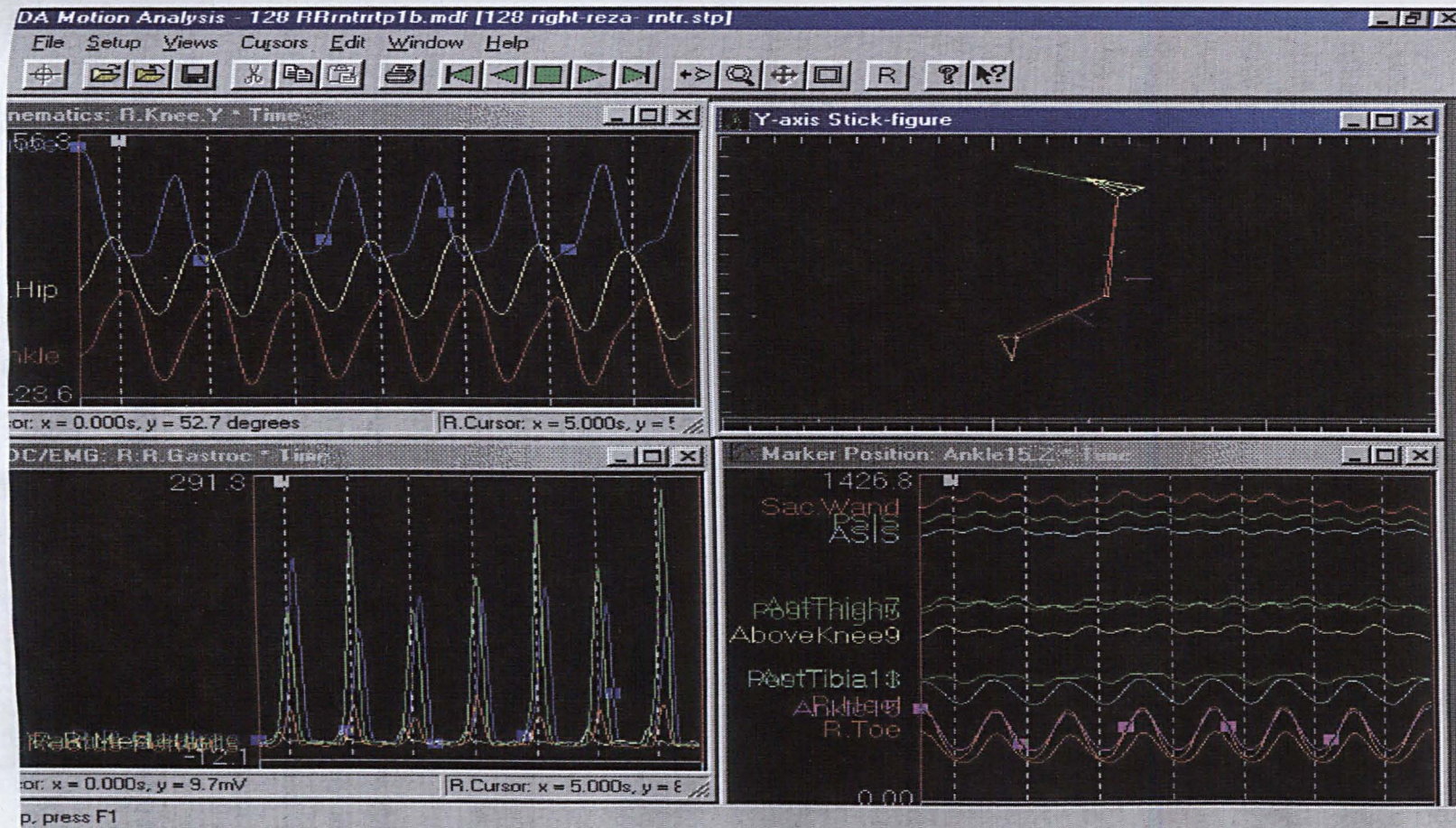

NB: Each two continuous dashed lines represent a complete gait cycle.

CHAPTER FIVE - RESULTS

5.1. Characteristics of the Study Sample

5.1.1. Control Subjects

The control subjects in this study were carefully selected and matched with the ACL-deficient subjects (Table 5-1) and they fulfilled the study entry criteria. Fifteen healthy control subjects were recruited for the study and consented to participate in the study. All subjects were in healthy condition and had no history of problems affecting their gait pattern. The control subjects consisted of 13 men and two women match the ACL-deficient subjects. Two of men and one of women were the control subjects from the pilot study and the other twelve were matched for the final study patients. Therefore, the control data in this study was derived from fifteen subjects, thirteen men and two women.

Table 5-1 Physical Profile of Study Participants.

Subjects' Physical Profile	Injured			Controls			Injured vs. Controls
	Mean	SD	N	Mean	SD	N	<i>P</i> ^I value
Age (years)	33	4	15	34	3	15	0.429
Height (m)	1.7	0.1	15	1.7	0.1	15	0.741
Weight (Kg)	82	12	15	76	11	15	0.200

N= number of subjects in a group, P= level of significance, I=Non-paired T-test, SD= Standard Deviation.

The *p* value in the statistical analysis of the age, height and weight between the control group and the ACL-deficient subjects showed no significant differences. This result showed that the control and the experimental groups were a good match with no significant differences ($P > 0.05$) (Figure 5-1).

5.1.2. ACL-Deficient Subjects

Fifteen ACL-deficient subjects were recruited from outpatient orthopaedic clinics. The patients who took part in the study were taken from of a group of nearly sixty ACL-deficient patients selected as suitable subjects for this study. The patients were recruited from the waiting list for ACL-reconstruction surgery in the orthopaedic clinic, Queen's Medical Centre. All of the ACL-deficient subjects were selected in accordance to the inclusion and exclusion criteria and filled the consent form to take part in the study (see Appendix).

The demographic characteristics of the control and ACL-deficient subjects are summarised in Table 5-2.

Table 5-2 Characteristics of the ACL-Deficient and Control Group.

Subjects' Characteristics	ACL-deficient Subjects			Normal Subjects
Numbers	15			15
Tested side	9 Rt & 6 Lt			9 Rt & 6 Lt
Sex	13 Males & 2 Females			13 Males & 2 Females
Age (yr.)*	33 ± 4 (26 - 40)			34 ± 2.7 (30 - 40)
Height (m)	1.73 ± 0.1			1.72 ± 0.1
Mass (Kg.)	82 ± 12.5 (62 - 103)			76 ± 11.2 (62 - 96)
Dominant Leg	Rt.			Rt.
Speed of walking on level ground (m/sec)	Braced	Non B/T	Taped	Non Braced or Taped
	1.3 ± 0.2	1.3 ± 0.2	1.3 ± 0.2	
Speed of walking on the treadmill (Km/hr.)	3.6 Km / hr (1 m/sec)			3.6 Km / hr (1 m/sec)
Speed of running on the treadmill (Km/hr.)	10 Km / hr (2.8 m/sec)			10 Km / hr (2.8 m/sec)

* Data ± is SD

All ACL-deficient subjects had a unilateral ACL-deficient knee and the non-injured knee was apparently healthy. All control subjects and patients were right leg-dominant. Nine (60%) of the patients had right knee involvement and six (40%) had left knee deficiency. The diagnostic tool used for the ACL-deficient subjects was an important issue for the researcher. Table 5-3 shows the diagnostic tools used for the patients in this study, the detail of the physical examination tests applied to the patients and the Lysholm scores quantified for each patient. The investigator, who is a physiotherapist and has some experience of working with orthopaedic patients, carried out the physical examination tests on the subjects. Twelve (80%) of the patients were diagnosed by arthroscopy and three (20%) of them by MRI. Two patients were diagnosed by both arthroscopy and MRI. The time past injury and the Lysholm score of the ACL-deficient subjects have also been mentioned in the diagram.

With regard to the increased number of cases of ACL-deficiency in athletic individuals, this study was carried out only on amateur athletes with a history of involvement in sports and exercise. The professional athletes were excluded from the study due to the possible difference in muscle strength between them and the amateur athletes (e.g. stronger hamstring muscles in the professional athletes). The index for amateur or professional athletic in our study was having exercise twice week (DeVita *et al.*, 1992).

Out of fifteen subjects tested in each group, ten (66.7%) subjects had a history of amateur exercise between 2.5 and 7.5 years. The rest of them (33.3%) had been involved in amateur sports more than 7.5 years.

Figure 5-1 Boxplots Showing the Physical Profile of Study Participants.

Comparison of the "Height" of the ACL-Deficient and Control Subjects

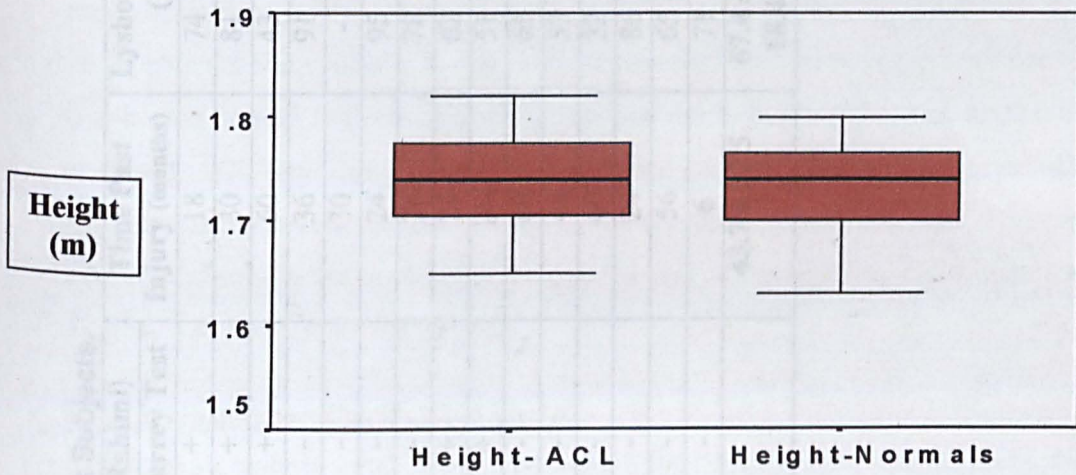

Comparison of the "Age" of the ACL-Deficient and Control Subjects

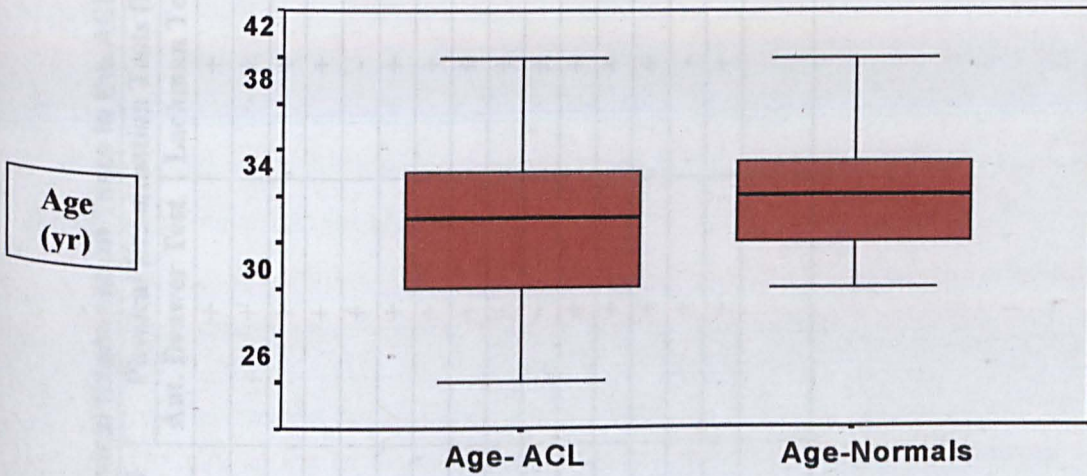

Comparison of the "Mass" of the ACL-Deficient and Control Subjects

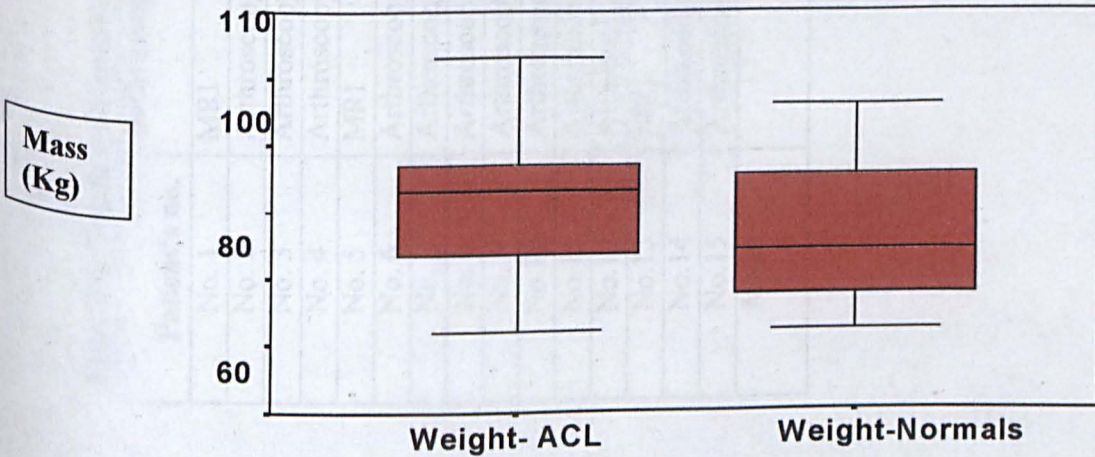

Table 5-3 Detailed Diagnosis and Physical Examination Tests in the ACL-Deficient Subjects.

Patient's no.	Arthroscopy /or MRI	Physical Examination Tests (By Abbas Rahimi)			Time Past Injury (months)	Lysholm Score (%)	
		Ant. Drawer Test	Lachman Test	McMurrey Test			
No. 1	MRI	+	+	+	18	74	Fair
No. 2	Arthroscopy	+	+	+	30	81	Fair
No. 3	Arthroscopy & MRI	+	+	+	60	43	Poor
No. 4	Arthroscopy	+	+	-	36	91	Good
No. 5	MRI	+	-	-	30	-	-
No. 6	Arthroscopy	+	+	-	24	95	Good
No. 7	Arthroscopy	+	+	-	36	78	Fair
No. 8	Arthroscopy	+	+	+	24	62	Poor
No. 9	Arthroscopy	+	+	+	144	51	Poor
No.10	Arthroscopy	+	+	-	60	61	Poor
No.11	Arthroscopy	+	+	-	48	53	Poor
No.12	Arthroscopy	+	+	-	60	32	Poor
No.13	MRI	+	+	-	24	86	Good
No.14	Arthroscopy & MRI	+	-	-	56	65	Poor
No.15	Arthroscopy	+	+	-	6	71	Fair
Mean					43.7 ± 32.5	67.4 ± 18.4	

5.2. Comparison of the Control Subjects and the Study Group

Tables 5-4 to 5-36 summarise the kinematic data including temporospatial parameters, range of motion (ROM), joint positions and tibial anterior/posterior (A-P) displacement in the patients and control subjects. The comparisons have been carried out between the non-braced normal subjects (control group) and the 1) braced, 2) taped, or 3) no-braced or taped ACL-deficient subjects (experimental group). The single factor ANOVA (repeated measure) and Student *t*-tests have been used in data analysis. A summary of the detailed results has been highlighted at the end of the Chapter. The values are given as mean and standard deviation (SD).

5.3. Kinematic Data Analysis

Although all records were carried out three-dimensionally, only sagittal plane data was analysed in this study. By recording the hip, knee and ankle joint angles in the sagittal plane, the kinematic parameters of the control and patient groups were assessed. The rotation angle of the knee (horizontal plane) was also investigated in the control and the ACL-deficient subjects as some literature states that knee rotation angles are usually increased following ACL-deficiency. Using a new feature in CODA *mpx30* (virtual marker method), the anterior-posterior translation of the tibia relative to the femur was also calculated and the results are presented.

All kinematic parameters were measured in three test modes including walking on level ground, walking on the treadmill and running on the treadmill.

5.3.1. Temporospatial Gait Parameters

A summary of the temporospatial parameters including the speed of walking on level ground, stride length, stride time, strides per minutes, step length, step time, steps per minute, percent stance, single stance time and double stance time have been shown in Table 5-4. The differences between the variables in all groups have also been shown as Excel graphs in Figure 5-2.

Table 5-4 Mean (SD) of the Temporospacial Gait Parameters in the Normal and the ACL-Deficient Subjects during Walking on Level Ground.

Temporospacial gait Parameters	ACL-deficient subjects (n=15)						P-value	Normals (n=15)	
	Wkgrb ¹		Wkgrn ²		Wkgrtp ³			Wkgrn	
	Mean	SD	Mean	SD	Mean	SD		Mean	SD
Speed (m/s)	1.28	0.2	1.26	0.2	1.25	0.2	0.942	1.42	0.1
Stride Length (m)	1.35	0.2	1.31	0.1	1.34	0.1	0.743	1.43	0.1
Stride Time (s)	1.07	0.1	1.08	0.1	1.08	0.1	0.953	1.03	0.1
Strides/ Minute	56.17	4.0	55.69	3.8	55.85	2.7	0.945	59.33	3.8
Step Length (m)	0.68	0.1	0.68	0.1	0.67	0.1	0.911	0.72	0.0
Step Time (s)	0.54	0.0	0.54	0.0	0.54	0.0	0.950	0.51	0.0
Steps/Minute	112.25	8.0	111.39	7.6	111.70	5.4	0.955	118.55	7.5
Percent Stance	64.19	2.8	64.54	3.2	65.18	2.7	0.697	62.26	2.8
Single Stance (s)	0.38	0.0	0.38	0.0	0.37	0.0	0.620	0.38	0.0
Double Support(s)	0.15	0.0	0.16	0.0	0.17	0.0	0.709	0.12	0.0

¹Wkgrb= Walking on level ground with brace, ²Wkgrn= Walking on level ground without brace, ³Wkgrtp= Walking on level ground with tape, ⁴ The P-value was considered as P-value < 0.05.

As Table 5-4 and Figure 5-2 show, the ACL-deficient and control subjects demonstrated that temporospacial parameters were very similar to each other. The ANOVA tests showed that neither the brace nor the tape could significantly change the temporospacial parameters within the ACL-deficient subjects. However, the t-tests (Table 5-5) showed significant differences between the ACL-deficient and the control subjects. The ACL-deficient subjects generally walked with a significantly slower speed, shorter stride length, fewer strides per minute, greater step time, fewer steps per minute and consequently larger percentage stance and larger double support time. The non-paired t-tests showed that the braced ACL-deficient subjects walked faster than the non-braced ACL-deficient patients, although non-significantly and showed a speed closer to the control group (P=0.027 vs. P=0.009). However, the taping did not change the speed in ACL-taped patients (P=0.006 vs. P=0.009). Stride length was significantly shorter in the ACL-deficient subjects when compared to the control group (P=0.014). However, following wearing a FKB, the stride length increased, so that there was no significant difference between the braced ACL-deficient and the control subjects (P=0.162). Taping also increased the stride length in the ACL-deficient patients, although non-significantly. Wearing a FKB or taping did not significantly change the rest of the temporospacial gait

parameters in the ACL-deficient subjects. Tables 5-4 and 5-5 show the mean (SD), the results of repeated measures ANOVA and t-tests (non-paired and paired) in the temporospatial gait parameters in the ACL-deficient and the control subjects on different surfaces. In summary, despite the significant differences existed in most temporospatial gait parameters in the ACL-deficient subjects; neither the FKB nor the tape could significantly change the variables within the ACL-deficient subjects. The occurred changes reached a significant level in some parameters only when compared with the control subjects.

Table 5-5 Results of t-tests in Temporospatial Gait Parameters between the Normal and the ACL-Deficient Subjects.

T-tests Results	Non-paired t-tests			paired t-tests	
	normals vs. non-braced ACL	normals vs. braced ACL	normals vs. taped ACL	non-braced ACL vs. braced ACL	non-braced ACL vs. taped ACL
Speed	0.009	0.027	0.006	0.322	0.802
Stride Length	0.014	0.162	0.082	0.430	0.392
Stride Time	0.152	0.246	0.192	0.509	0.705
Strides/Minute	0.022	0.049	0.011	0.510	0.798
Step Length	0.089	0.155	0.042	0.762	0.434
Step Time	0.019	0.046	0.008	0.546	0.888
Steps/Minute	0.024	0.052	0.012	0.551	0.799
Percent Stance	0.102	0.141	0.017	0.493	0.276
Single Stance	0.966	0.980	0.485	0.969	0.112
Double Support	0.030	0.039	0.007	0.435	0.281

Figure 5-2 "Temporospatial Gait Parameters".

Speed

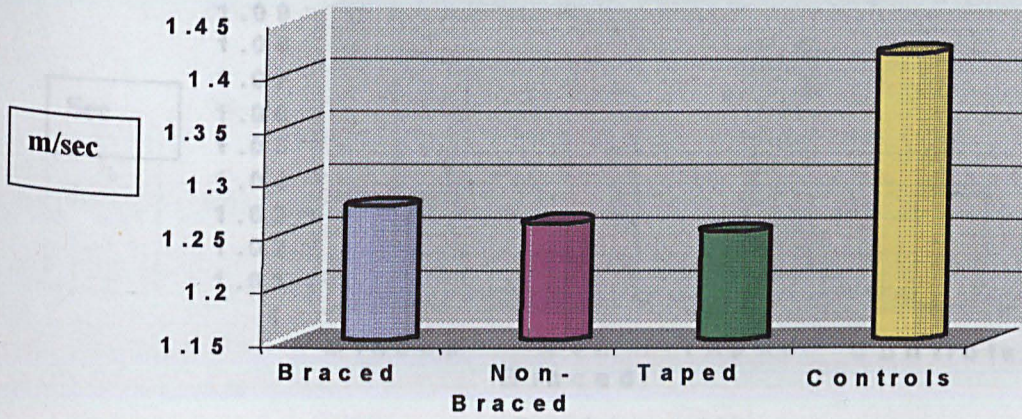

Stride Length

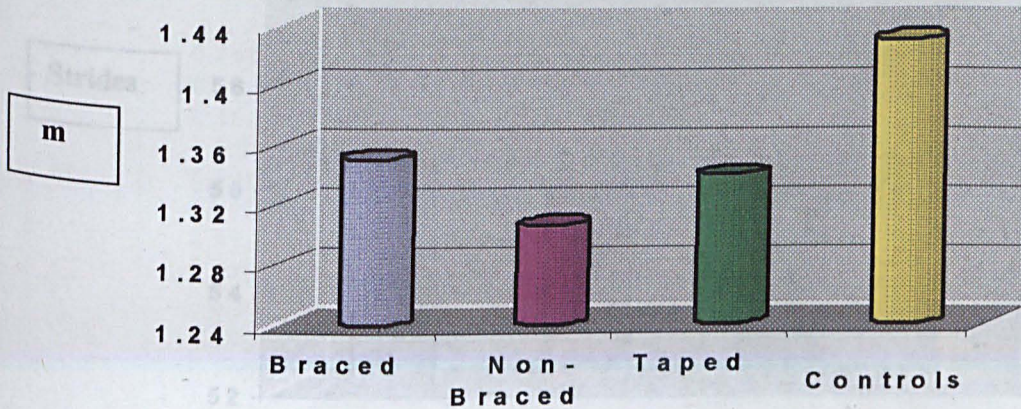

Steps / minute

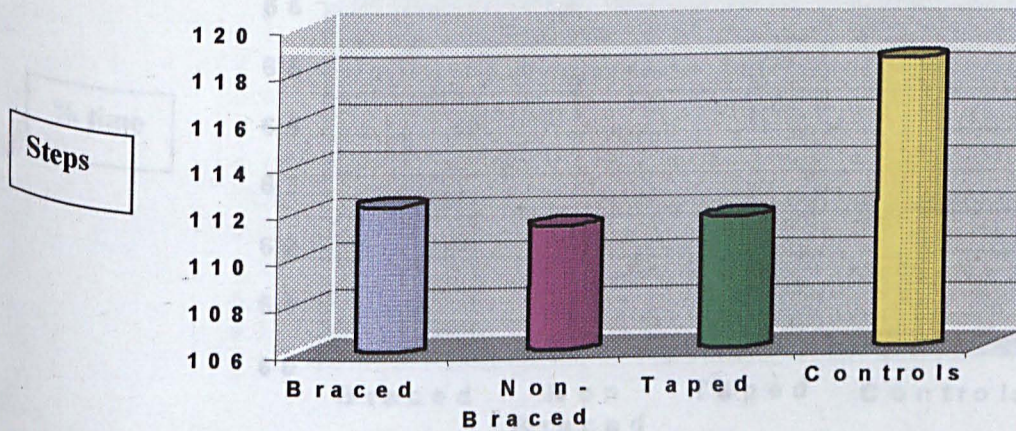
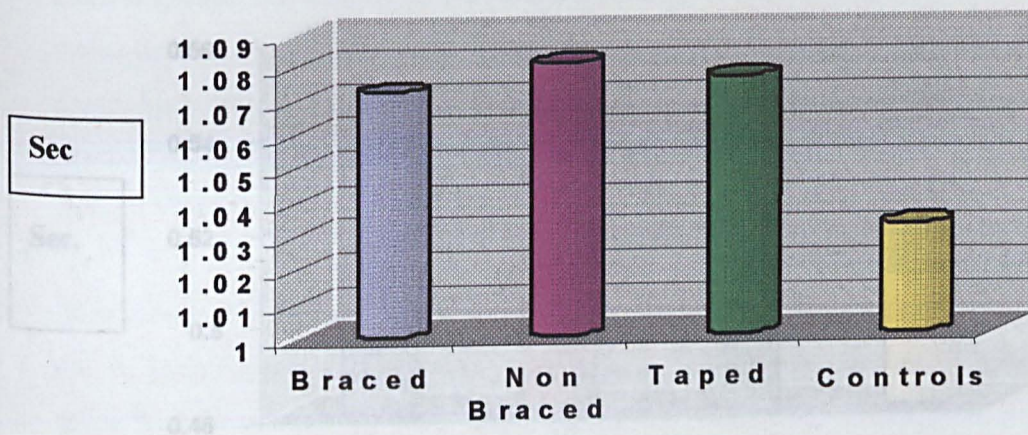
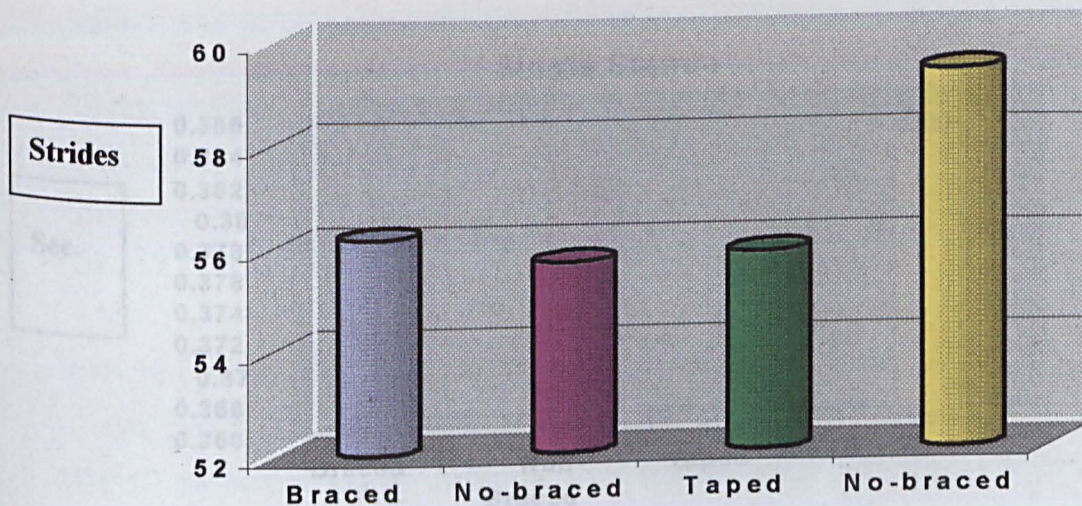

Figure 5-2 "Temporospatial Gait Parameters", cont.

Stride Time



Stride / Minutes



Stance Percentage

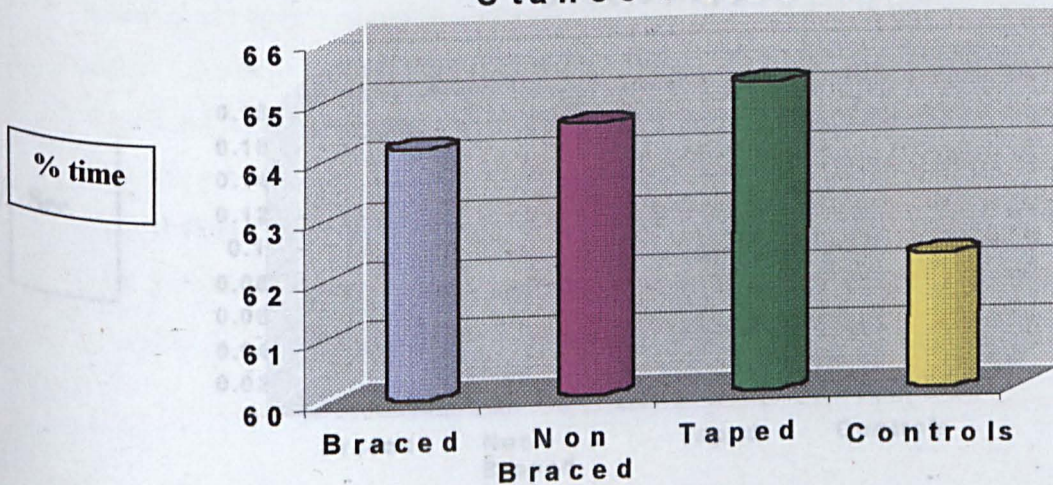
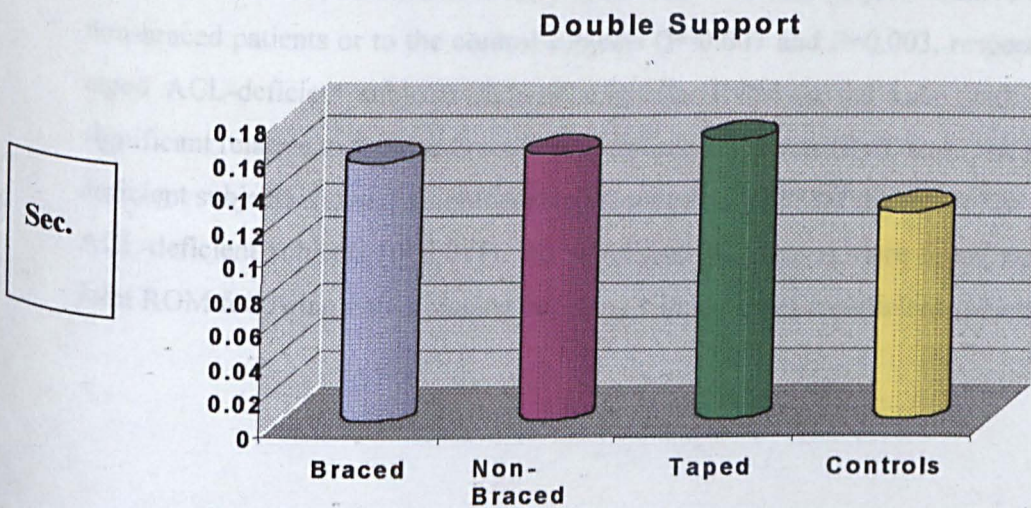
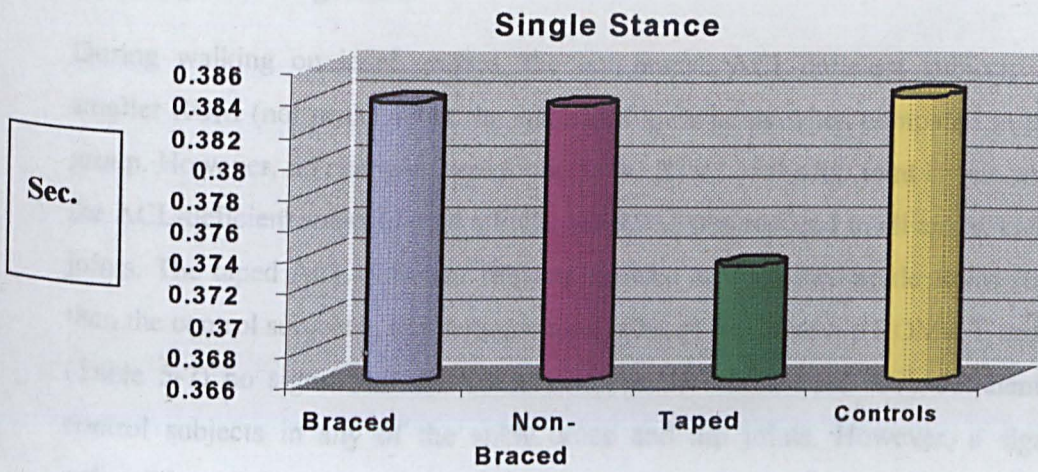
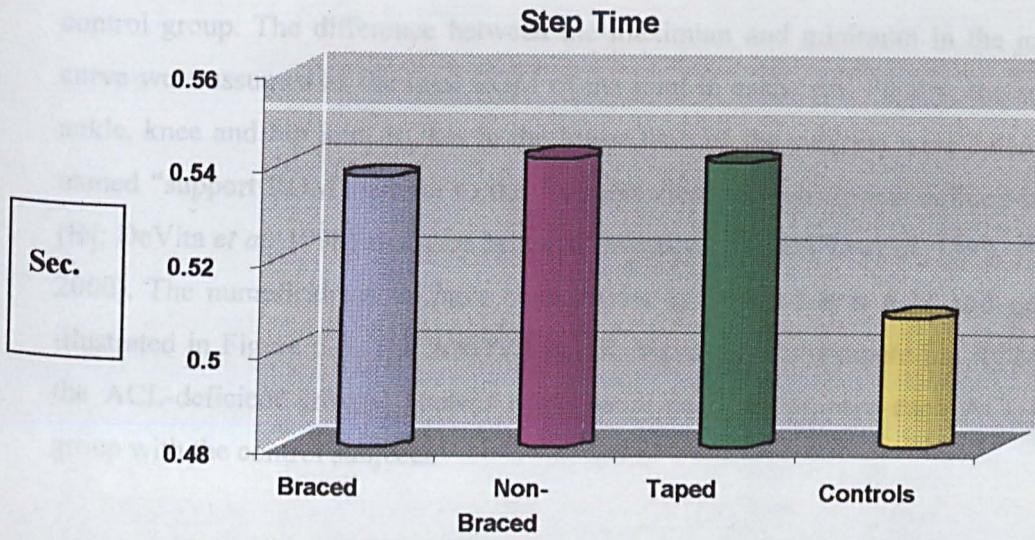

Figure 5-2 "Temporospatial Gait Parameters", cont.



5.3.2. Range Of Motion (ROM)

The peak-to-peak range of motion (ROM) of the ankle, knee and hip joints were measured in the ensemble curves of the ACL-deficient subjects and compared with the control group. The difference between the maximum and minimum in the joint angle curve were assumed as the total ROM of the joint in each task. Finally, the sum of the ankle, knee and hip joint ROMs in the lower limb of the subjects were calculated and named "support ROM" similar to the "support moment" which was defined by Winter (IN: DeVita *et al.* 1998) and used by some investigators (DeVita *et al.* 1992, 1998; Hof, 2000). The numerical results have been shown in Tables 5-6 to 5-11 and graphically illustrated in Figure 5-3. The ANOVA results were used to compare the ROMs within the ACL-deficient groups. Student *t*-tests were used to compare each ACL-deficient group with the control subjects.

Walking on level ground

During walking on level ground, the non-braced ACL-deficient subjects showed a smaller ROM (not peak) about the ankle and knee joints when compared to the control group. However, no changes were found in the ROM of the hip joint at this level. When the ACL-deficient subjects used a FKB, the ROM was reduced in all ankle, knee and hip joints. The taped ACL-deficient subjects showed an increased ankle ROM (even more than the control subjects), but demonstrated reduced knee and hip ROMs. T-tests showed (Table 5-7) no significant difference between the non-braced ACL-deficient and the control subjects in any of the ankle, knee and hip joints. However, a significantly reduced knee ROM was found in the braced ACL-deficient subjects relative to either the non-braced patients or to the control subjects ($P=0.007$ and $P=0.003$, respectively). The taped ACL-deficient subjects showed a smaller ROM in the knee joint which was significant relative to the non-braced ACL-deficient subjects ($P=0.026$). The taped ACL-deficient subjects showed a significantly increased ankle ROM relative to the non-braced ACL-deficient subjects ($P=0.017$). No significant differences were found about the hip joint ROM following either bracing or taping within the ACL-deficient subjects.

Table 5-6 Mean (SD) of Range of Motion (ROM) in the Ankle, Knee and Hip Joints during Walking on Level Ground.

Walking on level ground		ACL-deficient subjects (degrees)			<i>P value</i>	Controls (degrees)
		Braced	Non-Braced	Taped		
ANKLE	Mean	27.4	27.6	30.2	0.405	28.1
	SD	5.1	4.6	5.6		
KNEE	Mean	37.0	40.2	39.5	0.235	41.5
	SD	3.2	4.4	4.3		
HIP	Mean	33.6	34.6	33.0	0.644	34.4
	SD	3.2	4.6	3.5		
Support ROM		98.0	102.4	102.7		104.1

Table 5-7 Results of *t*-tests in ROM of the Lower Extremity Joints while Walking on Level Ground.

Walking on level ground				
Non-paired T-tests		Ankle	Knee	Hip
Normals vs. non-braced ACL deficient		0.809	0.439	0.893
Normals vs. braced ACL deficient		0.746	0.007	0.588
Normals vs. taped ACL deficient		0.406	0.239	0.350
Paired T-tests				
Non-braced ACL vs. braced ACL-def.		0.660	0.003	0.968
Non-braced ACL vs. taped ACL-def.		0.017	0.026	0.108

The ACL-deficient subjects showed a 2% less "support ROM" in comparison to the control subjects during walking on level ground. The FKB reduced this value remarkably (4%↓); however, the taping did not change this value.

Walking on the Treadmill

Table 5-8 shows the mean (SD) and the "support ROM" of the ACL-deficient and the control subjects during walking on the treadmill. The non-braced ACL-deficient subjects showed greater ankle and hip joints' ROM, but smaller knee ROM during walking on the treadmill. Wearing a FKB did not significantly change the ankle and hip joints' ROM, but significantly reduced the knee ROM. The taped ACL-deficient subjects showed greater ankle but less hip and knee ROM during walking on the treadmill.

Table 5-8 Mean (SD) of ROM in the Ankle, Knee and Hip Joints during Walking on the Treadmill.

Walking on the treadmill		ACL-deficient subjects			<i>P value</i>	Controls
		Braced	Non-Braced	Taped		
ANKLE	Mean	27.0	27.8	28.3	0.742	23.2
	SD	3.6	4.7	4.0		
KNEE	Mean	33.8	36.9	36.0	0.165	37.5
	SD	3.7	4.3	4.0		
HIP	Mean	29.5	29.2	27.8	0.443	27.4
	SD	3.3	3.4	3.5		
Support ROM		90.3	93.9	92.2		88.1

T-tests (Table 5-9) showed a significant difference in ankle ROM between the non-braced ACL-deficient and the control subjects ($P=0.037$) which was changed to a non-significant level following bracing, indicating the restrictive effect of the FKB. The taping, however, could not significantly change the ankle ROM in this level. No significant differences were found in the knee and hip ROMs between the non-braced ACL-deficient and the control groups. Wearing a FKB significantly reduced the knee ROM ($P=0.026$), but taping did not change it. Taping could reduce the knee ROM non-significantly while walking on the treadmill ($P=0.182$). The "support ROM" showed a 6.7% increase in the ACL-deficient subjects relative to the control group. Either the FKB or the tape reduced "support ROM" as the brace reduced it 4% and the tape reduced it 2%.

Table 5-9 Results of *t*-tests of ROM in the Ankle, Knee and Hip Joints during Walking on the Treadmill.

Walking on the treadmill			
Non-paired T-tests	Ankle	Knee	Hip
Normals vs. non-braced ACL deficient	0.037	0.733	0.196
Normals vs. braced ACL deficient	0.053	0.026	0.121
Normals vs. taped ACL deficient	0.014	0.374	0.771
Paired T-tests			
Non-braced ACL vs. braced ACL-def.	0.186	0.002	0.700
Non-braced ACL vs. taped ACL-def.	0.393	0.182	0.014

Running on the Treadmill

Table 5-10 shows the mean (SD) and "support ROM" of the ACL-deficient and control subjects during running on the treadmill. During running on the treadmill, the ROM was greater in the ankle and knee joints in the non-braced ACL-deficient subjects, but remained virtually unchanged in the hip joint when compared to the control subjects. Neither bracing nor taping could significantly change the ankle, knee or hip ROMs

during running on the treadmill ($P>0.05$). T-tests (Table 5-11) also revealed no significant differences between the control group and any of the patient groups. In other words, although the ACL-deficient subjects showed a greater ankle and knee ROM, none of the supports tested in this study, could significantly change them. The “support ROM” showed that the ACL-deficient subjects demonstrated a 66% increase in total ROM in the lower limb joint. Neither the FKB nor the tape could clearly change the “support ROM” at this level.

Table 5-10 Mean (SD) of Total Range of Motions (ROM) in the Ankle, Knee and Hip Joints during Running on the Treadmill.

Running on the treadmill		ACL-deficient subjects			P value	Controls
		Braced	Non-Braced	Taped		
ANKLE	Mean	36.5	37.2	36.4	0.919	32.0
	SD	4.6	5.9	4.9		8.4
KNEE	Mean	37.0	37.2	36.9	0.991	34.5
	SD	5.5	6.6	5.5		6.2
HIP	Mean	29.7	29.1	28.6	0.760	30.5
	SD	3.8	3.3	4.0		3.5
Support ROM		103.2	103.5	101.8		97.1

Table 5-11 Results of t-tests in ROM Measurement during Running on the Treadmill.

Running on the treadmill			
Non-paired T-tests	Ankle	Knee	Hip
Normals vs. non-braced ACL-deficients	0.103	0.326	0.317
Normals vs. braced ACL deficient	0.132	0.326	0.613
Normals vs. taped ACL deficient	0.148	0.346	0.224
Paired T-tests			
Non-braced ACL vs. braced ACL-Deficient.	0.543	0.799	0.269
Non-braced ACL vs. taped ACL-Deficient.	0.309	0.770	0.346

“Support ROM” at a Glance

The results of the “support ROM” in all subjects (Table 5-6) revealed that the control subjects had the greatest ROM during walking on level ground but not running on the treadmill. Walking on the treadmill showed the smallest ROM in the control subjects. The non-braced ACL-deficient subjects showed different results. During walking on level ground, they showed smaller “support ROM” than that of the control group. However, during treadmill trials (either walking or running on the treadmill) they showed greater ROM than those of the control group. Wearing a FKB reduced the “support ROM” in all trials, although no clear differences were found during running on

the treadmill. Following taping, the "support ROM" showed a very small reduction, which was smaller than that which occurred following bracing.

Figure 5-3 shows that when the subjects walked on the treadmill, the ROM of the hip joint reduced significantly (in comparison to the other groups). However, during running on the treadmill, the ankle ROM increased significantly relative to other test mode trials. As a result, the greatest joint ROM was represented in the hip joint during walking on level ground and in the ankle joint during running on the treadmill.

Figure 5-3 Histograms Showing the Range of Motion (ROM) in the ACL-Deficient and Control Subjects.

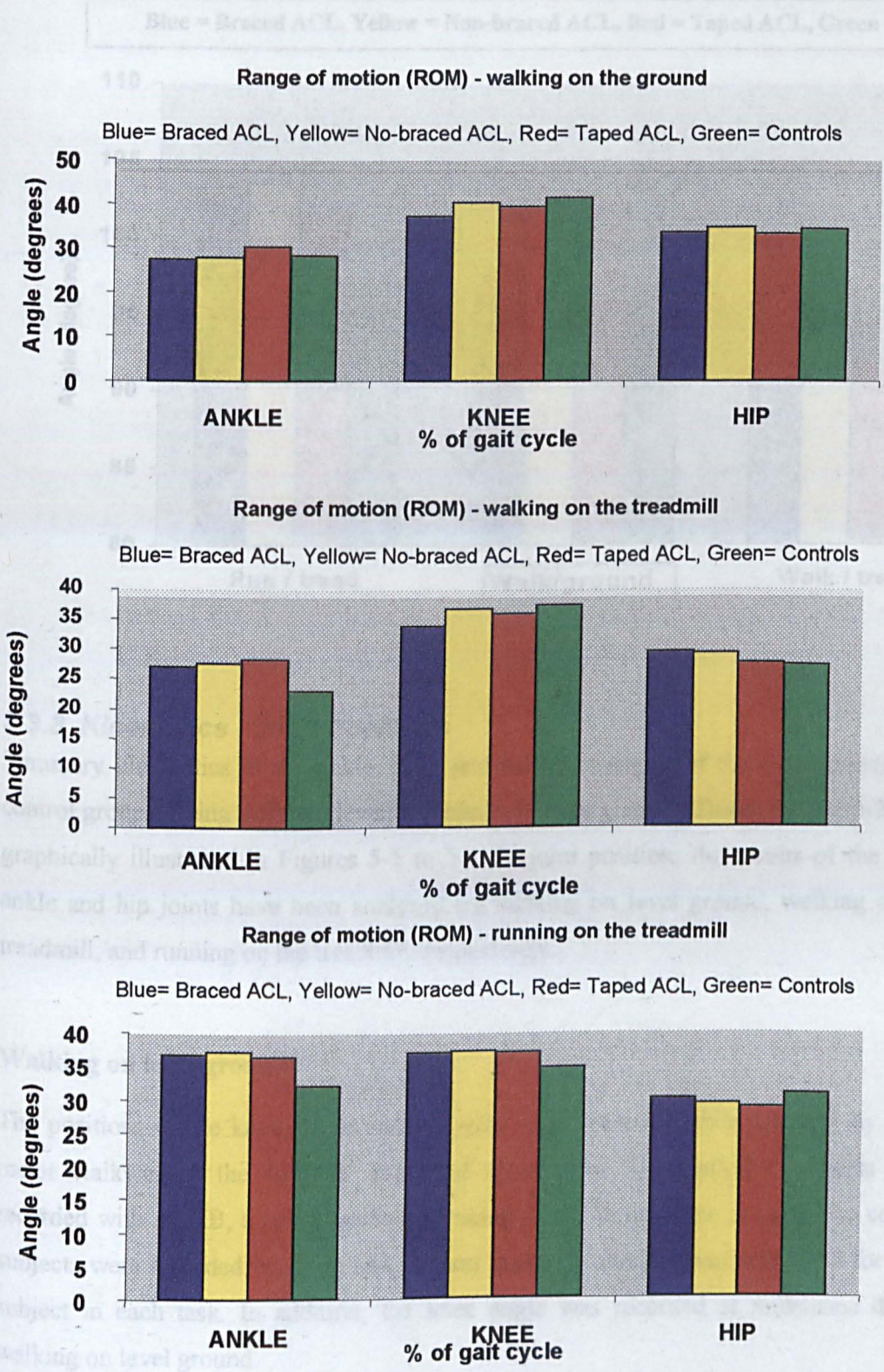
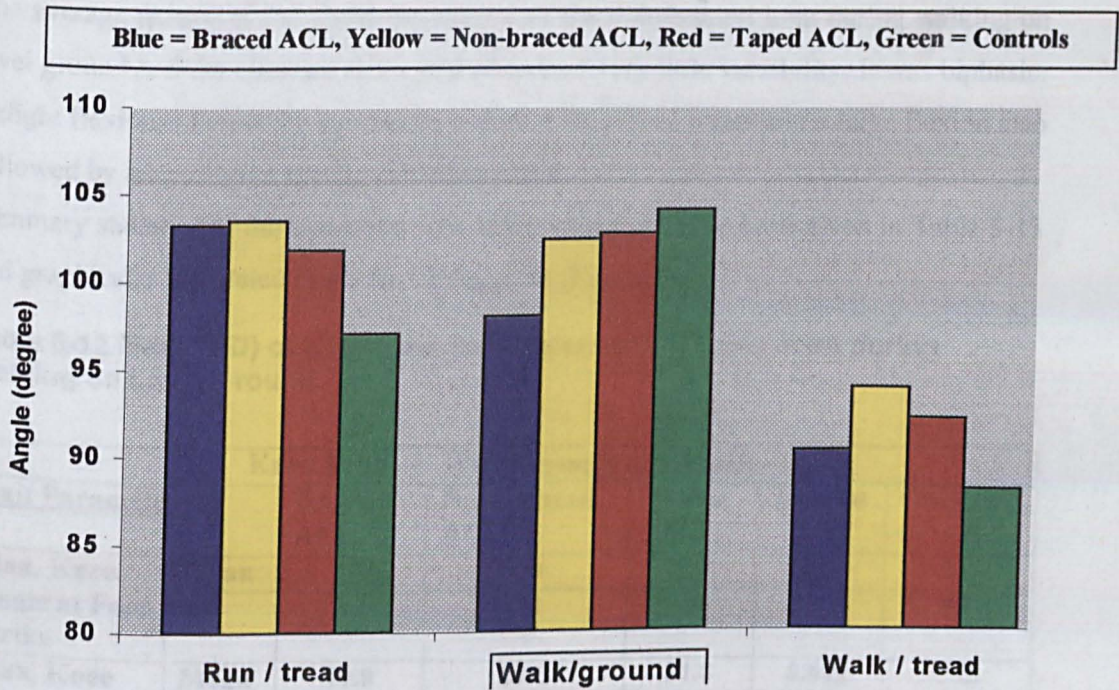

Figure 5-4 "Support ROM" in the ACL-Deficient and Control Subjects.



5.3.3. Kinematics - Joint Positions

Summary kinematics of the ankle, knee and hip joint angles of the experimental and control groups during different levels of tests have been given in Tables 5-12 to 5-31 and graphically illustrated in Figures 5-5 to 5-7. In joint position, the results of the knee, ankle and hip joints have been analysed for walking on level ground, walking on the treadmill, and running on the treadmill, respectively.

Walking on level ground:

The positions of the knee, ankle and hip joint were recorded while walking on a 16-meter walkway at the subjects' preferred speed. The ACL-deficient subjects were recorded with a FKB, a spiral method of taping and with no brace or tape. The control subjects were recorded when no support was used. An average was calculated for each subject in each task. In addition, the knee angle was recorded at midstance during walking on level ground.

Knee Joint

The average pattern of the flexion/extension of the tibiofemoral joint during walking on level ground had the classical shape and contained very little variability. It was biphasic: a slight flexion followed by an extension during the stance phase and a large flexion also followed by an extension during the swing phase.

Summary statistics of the kinematic data in the knee joint have been given in Table 5-13 and graphically illustrated in the Excel diagrams (Figure 5-5).

Table 5-12 Mean (SD) of Kinematic Parameters of the Knee Joint during Walking on Level Ground.

Knee Joint - Walking on level ground						
Gait Parameters		Braced ACL	Non-Braced ACL	Taped ACL	P-value	Controls
Max. Knee Angle at Foot Strike	Mean	6.1	8.9	7.6	0.304	1.9
	SD	3.7	4.1	3.6		4.6
Max. Knee Flexion in Stance	Mean	19.9	20.5	21.8	0.812	16.2
	SD	6.9	6.6	6.3		4.1
Max. Knee Flexion in Swing	Mean	51.5	52.9	54	0.772	51.6
	SD	7.3	8.1	6.9		3.6
Mean Stance	Mean	18.6	18.8	20.5		16.1
Mean Swing	Mean	28.6	30.3	31.0		25.9

The P-value was considered as P-value < 0.05

Table 5-13 Results of t-tests of the Kinematic Parameters of the Knee Joint during Walking on Level Ground.

Knee Joint - Walking on level ground			
Non-Paired T-Tests	Max. Knee Angle At Foot Strike	Max. Knee Flex in Stance	Max. Flex in Swing
Normals vs. non-braced ACL	0.002	0.08	0.62
Normals vs. braced ACL	0.03	0.13	0.13
Normals vs. taped ACL	0.01	0.02	0.02
Paired T-Tests			
Non-braced ACL vs. braced ACL	0.04	0.81	0.81
Non-braced ACL vs. taped ACL	0.08	0.29	0.29

Analysis of the kinematic data of the knee joint during walking on level ground showed that the non-braced ACL-deficient subjects walked with a more-flexed knee and the

mean knee flexion angle during both the stance and swing phases was greater than that of the control subjects. The ANOVA analysis results indicated no significant differences within the ACL-deficient subjects at the heel strike when all supports were compared ($P=0.304$). The brace created walking with a less flexed-knee at heel strike and reduced knee flexion throughout the stance and swing phases although it was still higher than that of the control subjects. The taping, however, increased knee flexion in the swing phase. The most important effect of the brace was shown in the swing phase during walking on level ground. Wearing a FKB significantly reduced the mean swing value and shifted it towards the values of the normal subjects. T-tests (Table 5-13) showed that wearing a FKB significantly reduced the maximum knee angle at foot strike in the ACL-deficient subjects ($P=0.04$).

Knee Angles at Midstance

Table 5-14 shows the mean (SD) and the results of single factor ANOVA (repeated measures) of the knee angle at midstance during walking on level ground. Both the knee angle at midstance and the percentage time of the gait cycle period in which the midstance occurred were measured in the ACL-deficient subjects with different supports and were compared with those of the control group.

Table 5-14 Mean (SD) of Knee Angle at Midstance during Walking on Level Ground.

Parameters		Braced ACL	Non-braced ACL	Taped ACL	<i>P</i> value	Controls
Angle	Mean	16.1	19.9	20.4	0.427	22.0
	SD	4.1	6.9	6.6		6.2
% of Gait Cycle	Mean	15.6	14.4	14.9	0.467	13.9
	SD	1.6	2.7	2.5		0.7

Table 5-15 Results of *t*-tests of Knee Angle at Midstance during Walking on Level Ground.

Non - Paired <i>t</i> Tests	Angle	% of Gait Cycle
Normals vs. Non-braced ACL	0.083	0.51
Normals vs. Braced ACL	0.128	0.003
Normals vs. Taped ACL	0.018	0.21
Paired		
Non-braced ACL vs. braced ACL	0.21	0.22
Non-braced ACL vs. Taped ACL	0.22	0.72

As Table 5-14 shows the midstance percentage was significantly different between the braced ACL-deficient patients and the controls ($P=0.003$), but not within the

ACL-deficient subjects. The values of knee angle, however, showed no significant differences within the ACL-deficient subjects. Table 5-15 shows that, generally, the ACL-deficient subjects were not significantly different from the controls either in percentage time or in knee flexion angle. The ACL-deficient subjects did not reach midstance significantly later than the controls during walking on level ground. They showed a non-significantly less knee flexion angle at midstance ($P=0.083$). When the ACL-deficient subjects used a FKB, they showed even less knee flexion angle (although non-significant), while greater percentage time period of midstance when compared to the non-braced ACL-deficient subjects. Taping subjects, however, reached to midstance non-significantly later with a greater knee flexion. In summary, adding a FKB or taping did not significantly change the percentage time period or the value of the midstance angle in the ACL-deficient subjects.

Ankle Joint

During walking on level ground, the initial contact occurred when the normal subjects struck the ground at a neutral position, while the ACL-deficient subjects struck the ground with a small dorsiflexion angle. The summary of the ankle joint kinematics in the control and the ACL-deficient subjects with different supports has been given in Table 5-16 and graphically illustrated in Figure 5-5.

Table 5-16 Mean (SD) of Kinematic Parameters of the Ankle Joint during Walking on Level Ground.

Ankle Joint - Walking on level ground						
Ankle Parameters		Braced ACL	Non-Braced ACL	Taped ACL	<i>P-value</i>	Controls
Max. Ankle Angle at Foot Strike	Mean	1.5	0.6	0.9	0.642	0.5
	SD	1.6	2.7	1.9		4.5
Max. Ankle Dorsi- Flexion	Mean	12.3	13	14.4	0.570	12.7
	SD	3.4	4.7	5.3		5.2
Max. Ankle Plantar Flexion	Mean	-14.4	-14.1	15.2	0.873	-14.5
	SD	5.2	4.9	4.3		7.8
Mean Stance	Mean	3.8	4.1	4.5	0.891	2.9
	SD	2.8	3.5	4.1		4.7
Mean Swing	Mean	-4.3	-4.7	-4.7	0.932	-1.8
	SD	3.6	3.4	2.6		9.3

The P-value was considered as P-value < 0.05

Table 5-17 Results of t-tests of Kinematic Parameters of the Ankle Joint during Walking on Level Ground.

Ankle Joint - Walking on level ground					
Non-Paired T-Tests	At Heel Strike	Max. D.F.	Max. P.F.	Mean Stance	Mean Swing
Normals vs. non-braced ACL	0.932	0.885	0.782	0.507	0.359
Normals vs. braced ACL	0.504	0.826	0.973	0.602	0.419
Normals vs. taped ACL	0.792	0.448	0.819	0.409	0.346
Paired T-Tests					
Non-braced ACL vs. braced ACL	0.207	0.700	0.604	0.805	0.610
Non-braced ACL vs. taped ACL	0.495	0.596	0.306	0.550	0.974

Analysis of the ankle joint kinematics during walking on level ground showed that the ACL-deficient subjects walked in a very similar manner to the control subjects and no significant difference was found between them in any of studied variables. Neither bracing nor taping was able to significantly change the kinematics of the ankle joint during walking on level ground (Figure 5-5). T-tests (Table 5-17) also showed no significant differences within the ACL-deficient groups or between the ACL-deficient subjects and the control group.

Hip Joint

In the current study and in agreement with the literature, the hip motion followed a nearly sinusoidal pattern. The maximum hip extension occurred at toe-off and the maximum hip flexion occurred in mid to terminal swing. As velocity increased, the swing phase hip flexion increased.

Table 5-18 shows the mean (SD) of the kinematic parameters of the hip joint in all subjects during walking on level ground. Table 5-19 shows the results of the t-test analysis of the hip kinematics during walking on level ground.

Table 5-18 Mean (SD) of Kinematic Parameters of the Hip Joint during Walking on Level Ground.

Hip Joint - Walking on level ground						
Hip Parameters		Braced ACL	Non-Braced ACL	Taped ACL	P-value	Controls
Max. Hip Angle at Foot Strike	Mean	17.7	18.6	18.7	0.896	13.8
	SD	5.8	5.7	4.8		8.6
Max. Hip Extension in Stance	Mean	-14.1	-14.6	-13.1	0.904	-19.7
	SD	7.2	7.3	7.3		7
Max. Hip Flexion in Swing	Mean	16.3	17.3	17.8	0.811	11.8
	SD	5.4	6	5.7		8.9
Mean Stance	Mean	-0.8	-0.8	0.2	0.862	-5
	SD	4.6	4.3	4.6		7.7
Mean Swing	Mean	6.9	8.4	8.2	0.761	5.1
	SD	4.7	5.3	5.3		8.7

[†] The P-value was considered as P-value < 0.05

Table 5-19 Results of t-tests of Kinematic Parameters of the Hip Joint during Walking on Level Ground.

Hip Joint - Walking on level ground					
Non-Paired T-Tests	At Foot Strike	Max. Ext. in Stance	Max. Flex in Swing	Mean Stance	Mean Swing
Normals vs. non-braced ACL	0.139	0.107	0.146	0.139	0.313
Normals vs. braced ACL	0.212	0.069	0.163	0.130	0.553
Normals vs. taped ACL	0.118	0.043	0.079	0.078	0.332
Paired T-Tests					
Non-braced ACL vs. braced ACL	0.564	0.872	0.416	0.996	0.199
Non-braced ACL vs. taped ACL	0.881	0.013	0.420	0.030	0.774

Analysis of hip joint movement showed that, although a more flexed hip was found in the non-braced ACL-deficient subjects in loading response stage, which was reduced when a FKB was used, none of the differences in hip joint kinematics were statistically significant between the ACL-deficient and the control subjects. Taping showed no difference on the hip joint kinematics during walking on level ground between the control and the ACL-deficient subjects. However, the taping could significantly reduce the maximum hip extension angle during walking on level ground ($P=0.013$). The mean stance value was significantly reduced only in the taped ACL-deficient subjects ($P=0.030$).

In summary, the ACL-deficient subjects walked with a more hip flexed position relative to the control subjects. The braced ACL-deficient subjects tended to walk with a slight

extension, although they were still more flexed than the control group. Taping did not significantly change the style of walking in the taped ACL-deficient subjects.

The above-mentioned results have been graphically illustrated in Figures 5-3.

Walking on the Treadmill

The joint angles of the knee, ankle and hip joints were recorded in the ACL-deficient subjects with different knee supports, and in the control subjects without any support. They were studied during walking on the treadmill at a constant speed of 3.6 Km/hr (1 m/sec). The general picture of knee movement corresponded with that of walking on level ground. It was biphasic and started with a slight knee flexion followed by an extension in the late stance phase. The maximum knee flexion was lower, in stance phase, than that of walking on level ground. It reached to 12-16° knee flexion in approximately 16% of the gait cycle, and then reduced to 8-14° of knee flexion in 35% of the gait cycle. It reached to 20-25° of maximum knee flexion at toe-off and peaked to 39-44° at 70% of the gait cycle. The stance phase was 15% shorter than that of when walking on level ground.

Knee Joint

The kinematic parameters of the knee joint during walking on the treadmill have been summarised numerically in Table 5-19 and graphically shown in Figure 5-6.

During walking on the treadmill, the non-braced ACL-deficient subjects hit the treadmill with a greater flexed knee than that of the control subjects (although non-significant). When the patients used FKBs or tape, however, they struck the treadmill with an even more flexed knee ($P=0.03$). This is opposed to that of walking on level ground. Repeated measures ANOVA (Table 5-20) showed that there were no significant differences in knee kinematic parameters within the ACL-deficient groups during walking on the treadmill. Neither the brace nor the tape could significantly change any parameters in the knee joint when all supports were compared together. T-tests (Table 5-21), however, showed that taping caused a non-significantly greater knee flexion angle during swing phase ($P<0.73$), but significantly greater maximum knee angle at foot strike either within the ACL-deficient groups or between the ACL-deficient and the control groups ($P<0.03$).

Table 5-20 Mean (SD) of Kinematic Parameters of the Knee Joint during Walking on the Treadmill.

Knee Joint - Walking on the Treadmill						
Knee Parameters		Braced ACL	Non-Braced ACL	Taped ACL	P-value	Controls
Max. Knee Angle at Foot Strike	Mean	8.9	7.1	8.2	0.740	2.7
	SD	5.9	3.7	3.7		6.2
Max. Knee Flexion in Stance	Mean	18.8	18.7	18.7	0.997	13.7
	SD	5.2	4.4	5.4		5.1
Max. Knee Flexion in Swing	Mean	50.8	51.2	51.8	0.952	47.5
	SD	6.9	8.0	6.3		4.5
Mean Stance	Mean	14.7	14.6	15.4		9.0
Mean Swing	Mean	32.4	33.0	33.6		26.7

¹ The P-value was considered as P-value < 0.05

Table 5-21 Results of t-tests of Kinematic Parameters of the Knee Joint during Walking on the Treadmill.

Knee Joint - Walking on the treadmill			
Non-Paired T-Tests	At Foot Strike	Max. Flex in Stance	Max. Flex in Swing
Normals vs. non-braced ACL	0.07	0.03	0.19
Normals vs. braced ACL	0.03	0.03	0.20
Normals vs. taped ACL	0.03	0.04	0.08
Paired T-Tests			
Non-braced ACL vs. braced ACL	0.11	0.87	0.51
Non-braced ACL vs. taped ACL	0.0001	0.99	0.73

Ankle Joint

Table 5-22 shows a summary of the kinematic changes in the ankle joint of the ACL-deficient and control subjects during walking on the treadmill. All results have been graphically presented in Figure 5-6. In ankle motion during walking on the treadmill, the non-braced ACL-deficient patients struck the treadmill with a 2° dorsiflexion, which was not followed by a plantarflexion and sharply raised to the maximum dorsiflexion between 10.5° and 13° at 35% of gait cycle. After that, it plantarflexed to -1° at 55% at toe-off and peaked to -7.5° to -12.5° at 67% of gait cycle. It then dorsi-flexed again to 3° at 90% of gait cycle and then returned to its normal level in preparation for the next step.

Table 5-22 Mean (SD) of Kinematic Parameters of the Ankle Joint during Walking on the Treadmill.

Ankle Joint - Walking on the Treadmill						
Ankle Parameters		Braced ACL	Non-Braced ACL	Taped ACL	<i>P-value</i>	Controls
Max. Ankle Angle at Foot Strike	Mean	2.5	1.6	1.3	0.693	1.7
	SD	4.5	3.2	4.5		4.3
Max. Ankle Dorsi-Flexion	Mean	12.7	12.6	14.2	0.526	12.3
	SD	3.9	3.7	3.6		4.8
Max. Ankle Plantar Flexion	Mean	-13.5	-8.1	-13.6	0.045	-9.4
	SD	5.8	7	4.4		7.8
Mean Stance	Mean	6.3	7.1	7.3	0.713	6.6
	SD	3.4	3.7	2.7		4.2
Mean Swing	Mean	-4.4	-1.5	-4.3	0.168	-2.5
	SD	4.4	4.9	3.1		5.7

[†]The P-value was considered as P-value < 0.05.

Although the statistical analysis showed a non-significant difference in the kinematic parameters of the ankle joint at heel strike during walking on the treadmill, the braced and taped ACL-deficient subjects walked with a remarkable ankle plantar flexion angle. There were significant differences within the ACL-deficient groups in terms of maximum ankle plantar flexion ($P=0.045$) indicating more activities of the plantar flexor muscles.

Table 5-23 Results of t-tests of Kinematic Parameters of the Ankle Joint during Walking on the Treadmill.

Ankle Joint - Walking on the treadmill					
Non-Paired T-Tests	At Heel Strike	Max. D.F.	Max. P.F.	Mean Stance	Mean Swing
Normals vs. non-braced ACL	0.948	0.869	0.684	0.781	0.639
Normals vs. braced ACL	0.638	0.819	0.159	0.823	0.376
Normals vs. taped ACL	0.791	0.293	0.121	0.623	0.340
Paired T-Tests					
Non-braced ACL vs. braced ACL	0.349	0.847	0.007	0.170	0.011
Non-braced ACL vs. taped ACL	0.716	0.021	0.002	0.648	0.008

T-tests (Table 5-23) showed that both the FKB and the tape significantly increased the maximum ankle plantar flexion during walking on the treadmill ($P=0.007$, $P=0.002$, respectively) and either bracing or taping significantly increased the mean swing value of the ankle joint during walking on the treadmill ($P=0.011$, $P=0.008$, respectively) (Figure 5-4).

Hip Joint

The mean (SD) of the kinematic parameters of the hip joint in the normal and ACL-deficient subjects have been shown in Table 5-24 and are graphically presented in Figure 5-6.

Table 5-24 Mean (SD) of Kinematic Parameters of the Hip Joint during Walking on the Treadmill.

Hip Joint - Walking on the Treadmill						
Hip Parameters		Braced ACL	Non-Braced ACL	Taped ACL	P-value	Controls
Max. Hip Angle at Foot Strike	Mean	15.1	12.5	14.6	0.586	12.6
	SD	5.3	6.4	7.7		7.4
Max. Hip Extension in Stance	Mean	-12.5	-11.8	-11.8	0.956	-12.1
	SD	6.1	6.1	7		5.5
Max. Hip Flexion in Swing	Mean	17	13.5	15.5	0.454	13.9
	SD	6.1	6.2	7.5		7.1
Mean Stance	Mean	0.4	-0.5	0.9	0.872	-0.7
	SD	5.5	6.6	7.5		6.6
Mean Swing	Mean	5.1	4.8	6	0.893	5.4
	SD	4.9	6.4	7.4		6.2

¹ The P-value was considered as P-value < 0.05

As Table 5-24 shows, the ACL-deficient subjects demonstrated hip kinematics very similar to the control group. However, wearing a brace or tape led to a much greater flexion both in stance and in swing. The ACL-deficient patients showed a clearly greater flexed position through the gait cycle while using a FKB or taping.

Table 5-25 Results of t-tests of the Kinematic Parameters of the Hip Joint during Walking on the Treadmill.

Hip Joint - Walking on the treadmill					
Non-Paired T-Tests	At Foot Strike	Max. Ext. in Stance	Max. Flex in Swing	Mean Stance	Mean Swing
Normals vs. non-braced ACL	0.979	0.904	0.902	0.957	0.834
Normals vs. braced ACL	0.346	0.870	0.266	0.678	0.902
Normals vs. taped ACL	0.511	0.908	0.594	0.598	0.822
Paired T-Tests					
Non-braced ACL vs. braced ACL	0.005	0.476	0.004	0.222	0.143
Non-braced ACL vs. taped ACL	0.006	0.989	0.015	0.010	0.051

A repeated measure ANOVA showed no significant differences within the ACL-deficient groups when the supports were compared together. Table 5-24 revealed that the braced or taped ACL-deficient subjects started with a forward leaning position and showed more hip flexion in swing phase (P=0.005, P=0.006, respectively). T-tests (Table

5-25) showed that the maximum hip flexion angle in the swing phase was significantly increased following either the brace or the tape (brace more than tape and both $P < 0.05$).

Running on the Treadmill

The ACL-deficient subjects were also tested while running on the treadmill at a constant speed of 10 Km/hr. The subjects ran while holding the front bar of the treadmill, although they were encouraged not to lean forward.

Knee Joint

The kinematic parameters of the knee joint during running on the treadmill has numerically been presented in Table 5-26 and the related graphs have been plotted in Figure 5-7. The ACL-deficient subjects clearly showed more knee flexion during running on the treadmill when compared with the control subjects. All the knee kinematic parameters increased in the no-braced ACL-deficient subjects, although the difference did not reach to a significant level in any of the parameters. When a FKB or tape was used, the braced ACL-deficient subjects significantly showed less knee flexion angle at heel strike ($P = 0.0004$). The statistical analysis of the rest of the data showed non-significant differences within the ACL-deficient groups following either bracing or taping ($P > 0.05$). Taping could increase knee flexion angle in swing, although it was non-significant ($P = 0.09$).

Table 5-26 Mean (SD) of Kinematic Parameters of the Knee Joint during Running on the Treadmill.

Knee Joint - Running on the Treadmill						
Knee Parameters		Braced ACL	Non-Braced ACL	Taped ACL	<i>P-value</i>	Controls
Max. Knee Angle at Foot Strike	Mean	14.4	17.6	16.7	0.607	13.3
	SD	7.3	7.2	7.2		7.3
Max. Knee Flexion in Stance	Mean	33.2	32.2	33.2	0.923	29.2
	SD	5.2	7.4	6.7		4.2
Max. Knee Flexion in Swing	Mean	65.9	66.5	68	0.858	58.6
	SD	8.9	9.8	8.2		11.1
Mean Stance	Mean	26.8	25.7	26.0		22.3
Mean Swing	Mean	39.5	39.1	39.0		34.6

¹The P-value was considered as P-value < 0.05

Table 5-27 Results of t-tests of Kinematic Parameters of the Knee Joint during Running on the Treadmill.

Knee Joint - Running on the treadmill			
Non-Paired T-Tests	At Foot Strike	Max. Flex in Stance	Max. Flex in Swing
Normals vs. non-braced ACL	0.19	0.25	0.09
Normals vs. braced ACL	0.74	0.06	0.11
Normals vs. taped ACL	0.29	0.10	0.03
Paired T-Tests			
Non-braced ACL vs. braced ACL	0.0004	0.37	0.73
Non-braced ACL vs. taped ACL	0.94	0.30	0.09

The ACL-deficient subjects had a foot strike of approximately 17 degrees while it was 13.3 degrees in the control subjects. Then, it was rapidly increased to 32 degrees in the ACL-deficient patients and 29 degrees in the control group at around 18% of the gait cycle. They showed a peak of approximately 60 degrees at 70% of the gait cycle. Then the knee was extended to 12-15° in preparation for the next step.

Ankle Joint

The Ankle kinematic changes in the ACL-deficient and control subjects during running on the treadmill with different supports have been summarised in Table 5-28 and plotted in Figure 5-5.

The non-braced ACL-deficient subjects started with 10°-12° dorsiflexion and increased to a maximum of 14°-15° of dorsiflexion at 10% of gait cycle. Thereafter, they showed a plantarflexion of 2°-4° at 25% of gait cycle at toe-off position and reached a peak of -16° to -19° plantarflexion at 47% of gait cycle. Following this, the second dorsiflexion reached a neutral position at 72%-80% of gait cycle (the control subjects reached the position earlier than the patients). Then, the ankle reached to 10° dorsiflexion in preparation for the next step.

Table 5-28 Mean (SD) of Kinematic Parameters of the Ankle Joint during Running on the Treadmill.

Ankle Joint - Running on the Treadmill						
Ankle Parameters		Braced ACL	Non-Braced ACL	Taped ACL	<i>P-value</i>	Controls
Max. Ankle Angle at Foot Strike	Mean	10.7	10.9	11.3	0.946	11.8
	SD	3.9	4.9	5.3		3.9
Max. Ankle Dorsi Flexion	Mean	15.5	15.9	16.4	0.897	15.2
	SD	4.3	4.5	5.4		3.4
Max. Ankle Plantar Flexion	Mean	-21.3	-21.2	-20	0.836	-16.2
	SD	6	6.1	5.1		8
Mean Stance	Mean	11.7	11.8	12.9	0.804	12.4
	SD	3.7	4.3	5.5		3.8
Mean Swing	Mean	-7.0	-7.0	-6.2	0.912	-2.9
	SD	5.4	5.4	5.2		6.1

¹ The P-value was considered as P-value < 0.05

Table 5-28 showed that, in the stance phase the ACL-deficient subjects had an ankle position very similar to that of the control subjects. However, they showed a dominant plantar flexion in the swing phase when compared with the control subjects.

Table 5-29 Results of t-tests of Kinematic Parameters of the Ankle Joint during Running on the Treadmill.

Ankle Joint - Running on the treadmill					
Non-Paired T-Tests	At Heel Strike	Max. D.F.	Max. P.F.	Mean Stance	Mean Swing
Normals vs. non-braced ACL	0.833	0.683	0.115	0.717	0.101
Normals vs. braced ACL	0.486	0.859	0.101	0.638	0.104
Normals vs. taped ACL	0.795	0.516	0.200	0.721	0.183
Paired T-Tests					
Non-braced ACL vs. braced ACL	0.779	0.667	0.852	0.861	0.944
Non-braced ACL vs. taped ACL	0.409	0.224	0.196	0.077	0.206

Table 5-29 revealed that the difference between any of the kinematic parameters did not reach a significant level in any phases of the gait cycle. T-tests also showed no significant differences in ankle position values within the ACL-deficient groups or between the normal and ACL-deficient subjects during running on the treadmill. Overall, neither the FKB nor the tape significantly altered the ankle kinematic parameters in this mode of test.

Hip Joint

The kinematic parameters of the hip joint during running on the treadmill with and without a FKB or tape in the ACL-deficient and in normal subjects have been presented in Table 5-30. During running on the treadmill, the initial contact of the hip joint started at 23°-24° of flexion (much higher than those of walking on level ground and walking on the treadmill) and decreased to 4°-6° at 25% of gait cycle in toe-off position. Thereafter, it continued to extend, but did not reach a hyperextension level (as it did in the walking levels) and peaked at -1° to +1° about 40% of gait cycle. Since there was no double support during running on the treadmill, the extension continued in the swing phase. When the hip reached its maximum extension, the flexion started and reached to 26°-28.5° at around 90% of gait cycle. It then decreased to 24° in preparation for the next step.

Table 5-30 shows that the ACL-deficient subjects had very similar hip kinematics to the control subjects either before or after bracing or taping.

Table 5-30 Mean (SD) of Kinematic Parameters of the Hip Joint during Running on the Treadmill.

Hip Joint - Running on the Treadmill						
Hip Parameters		Braced ACL	Non-braced ACL	Taped ACL	<i>P-value</i>	Controls
Max. Hip Angle at Foot Strike	Mean	26.4	25.9	25.4	0.955	24.6
	SD	6.8	6.7	7.9		7
Max. Hip Extension in Stance	Mean	0.5	0.7	0.5	0.993	-1.8
	SD	4.3	4.4	5		8.5
Max. Hip Flexion in Swing	Mean	30.2	29.8	29.1	0.936	28.4
	SD	6.8	6.5	7.8		8.6
Mean Stance	Mean	17.4	16.6	16.6	0.957	15.1
	SD	6.9	7.2	8		10.4
Mean Swing	Mean	14.5	14.8	14	0.956	12.6
	SD	5.6	5.3	6.3		8.3

Table 5-31 Results of t-tests of Kinematic Parameters of the Hip Joint During Running on the Treadmill.

Hip Joint - Running on the treadmill					
Non-Paired T-Tests	At Foot Strike	Max. Ext. in Stance	Max. Flex in Swing	Mean Stance	Mean Swing
Normals vs. non-braced ACL	0.683	0.393	0.661	0.683	0.462
Normals vs. braced ACL	0.628	0.435	0.590	0.538	0.531
Normals vs. taped ACL	0.831	0.431	0.839	0.707	0.639
Paired T-Tests					
Non-braced ACL vs. braced ACL	0.625	0.754	0.746	0.369	0.704
Non-braced ACL vs. taped ACL	0.434	0.707	0.256	0.915	0.136

The ANOVA statistical analysis (Table 5-30) showed that the differences between the normal and the ACL-deficient subjects were not significant throughout the gait cycle, although the ACL-deficient subjects showed higher degrees of hip flexion angle at foot strike ($P=0.683$). T-tests (Table 5-31) also showed no significant differences within the ACL-deficient groups or between the normal and the ACL-deficient subjects in terms of the hip joint kinematics during running on the treadmill. In general, the lower limb joints showed similar angles between the patients and the control groups during running on the treadmill.

The graphs relating to hip kinematics during running on the treadmill have been illustrated in Figure 5-7.

Figure 5-5 Kinematics of the Ankle, Knee and Hip Joints during Walking on Level Ground.

Kinematics - Ankle joint- walking on level ground



Kinematics - Knee Joint - Walking on level ground

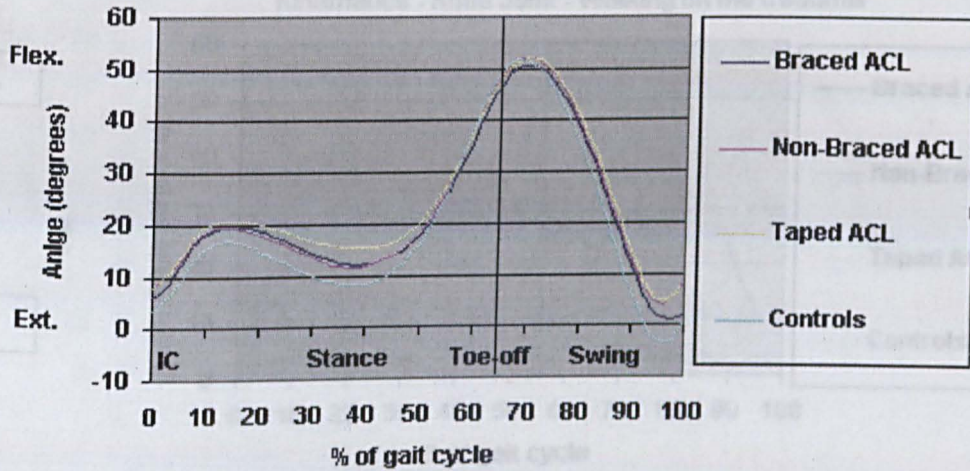

Kinematics - Hip joint- walking on level ground

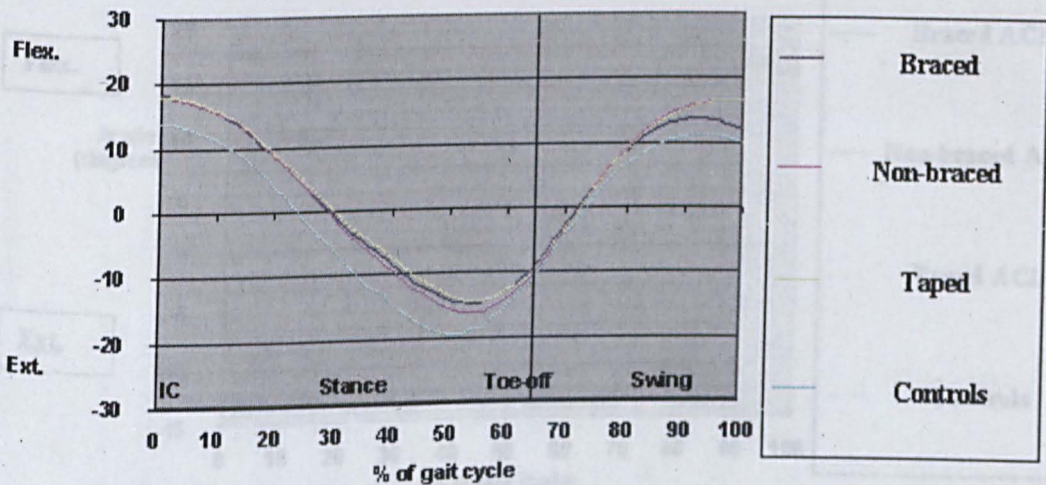
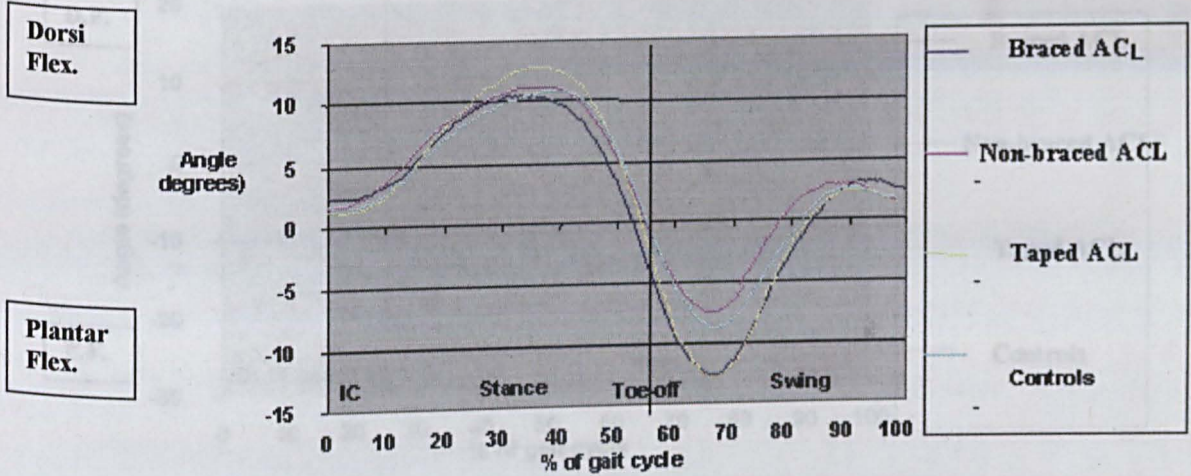
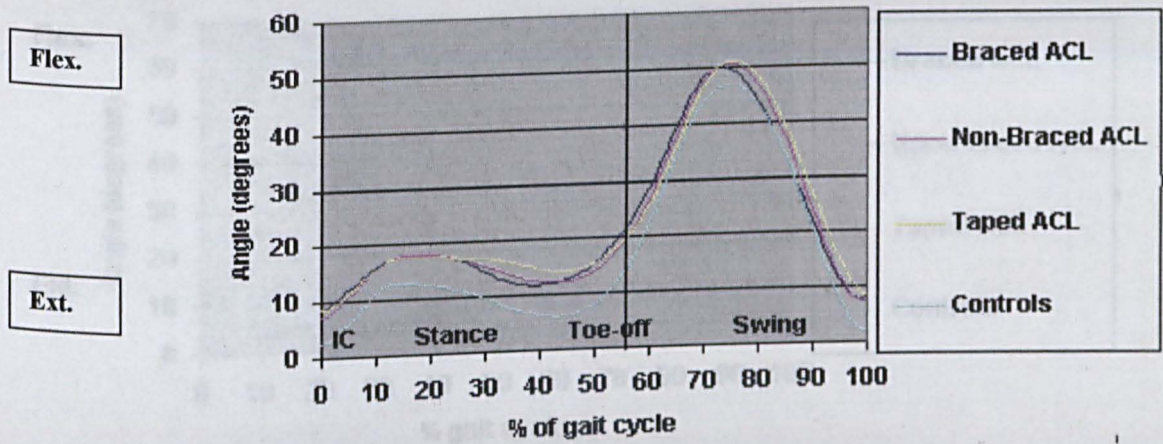

Figure 5-6 Kinematics of the Ankle, Knee and Hip Joints during Walking on the Treadmill.

Kinematics - Ankle joint - walking on the treadmill



Kinematics - Knee Joint - Walking on the treadmill



Kinematics - Hip joint - walking on the treadmill

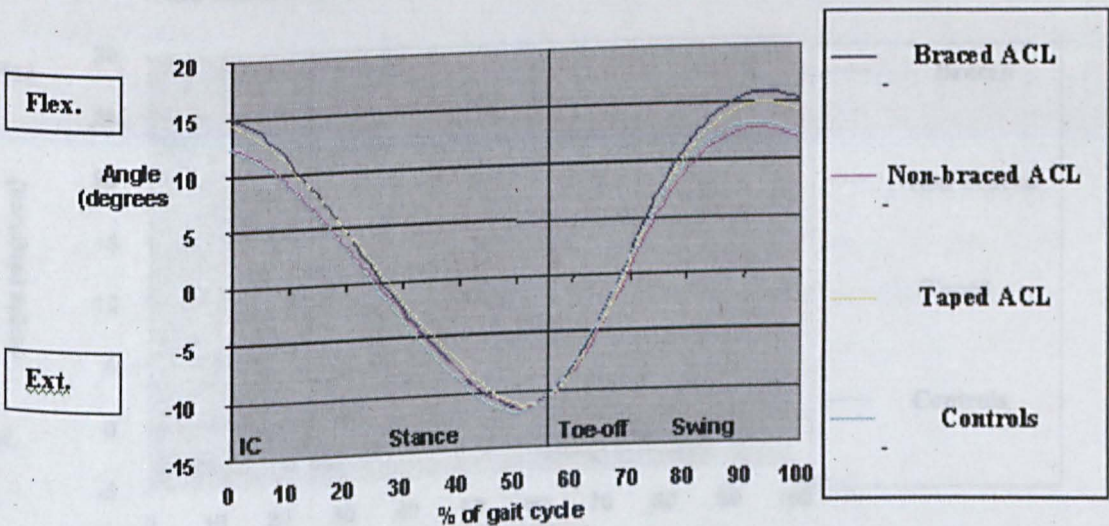
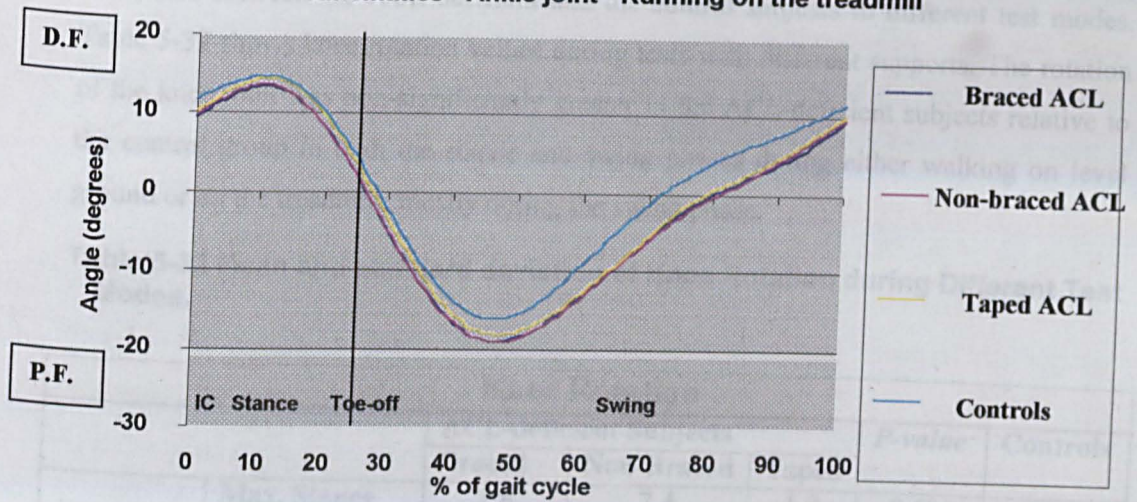
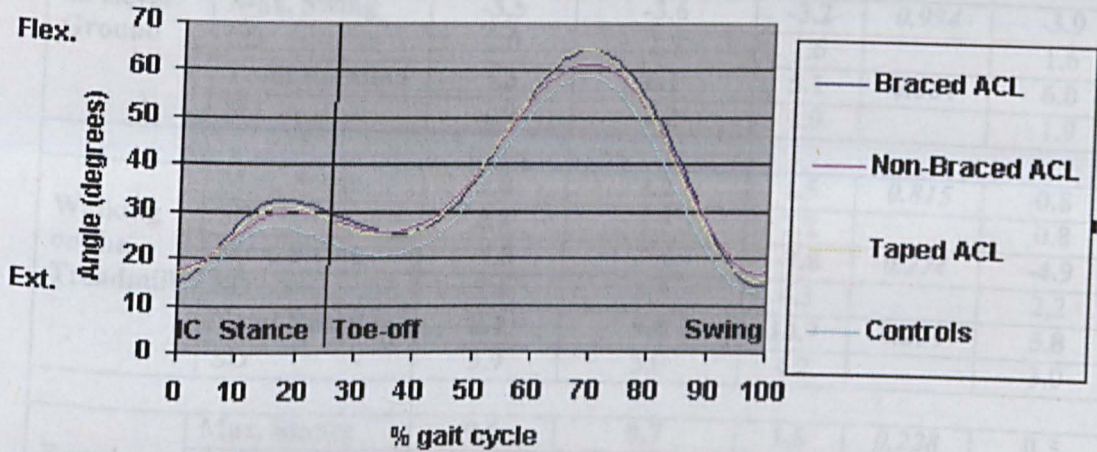

Figure 5-7 Kinematics of the Ankle, Knee and Hip Joints during Running on the Treadmill.

Kinematics - Ankle joint - Running on the treadmill



kinematics - Knee Joint - Running on the treadmill



Kinematics - Hip Joint - Running on the Treadmill

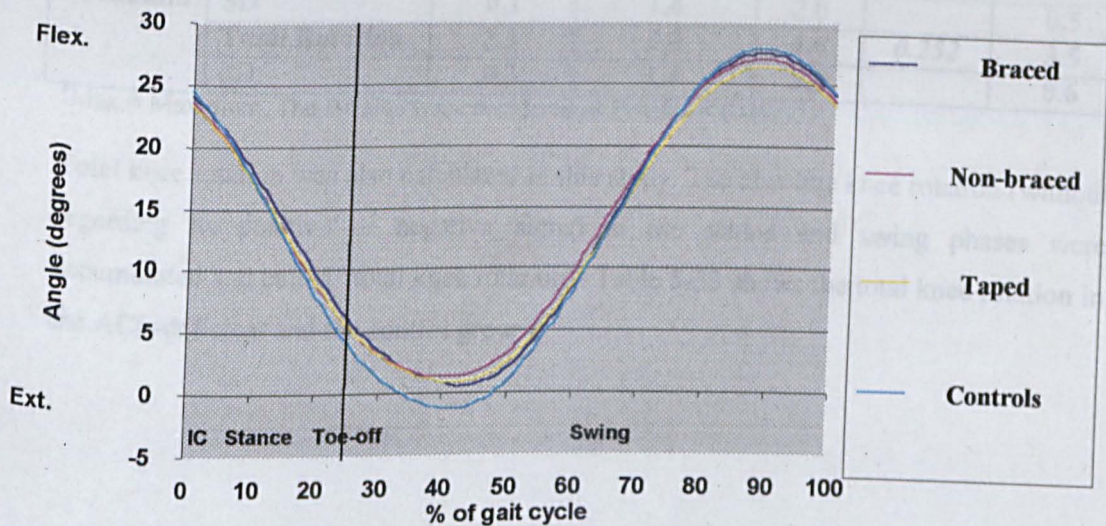

5.3.4. Knee Rotation

The maximum knee rotation in the stance and swing phases was measured and compared between the ACL-deficient and the control subjects in different test modes. Table 5-32 shows knee rotation values during tests with different supports. The rotation of the knee joint was non-significantly greater in the ACL-deficient subjects relative to the control group in both the stance and swing phases during either walking on level ground or on the treadmill, mostly during the swing phase.

Table 5-32 Mean and standard deviation of Knee Rotation during Different Test Modes.

Knee Rotation						
		ACL-deficient Subjects			<i>P-value</i>	Controls
		Braced	Non-Braced	Taped		
Walking on Level Ground	Max. Stance	1.8	2.4	1.9	0.693	2.1
	SD	1.1	1.6	0.9		1.7
	Max. Swing	-3.5	-3.6	-3.2	0.934	-3.9
	SD	2.0	2.7	1.6		1.6
	Total Rotation	5.3	6.1	5.1	0.584	6.0
	SD	1.9	2.2	1.9		1.9
Walking on the Treadmill	Max. Stance	2.0	2.2	1.5	0.815	0.8
	SD	2.8	1.5	3.2		0.8
	Max. Swing	-4.8	-7.6	-7.8	0.274	-4.9
	SD	5.4	3.5	4.3		2.2
	Total Rotation	8.1	9.8	10.7	0.296	5.8
	SD	3.9	3.0	4.2		3.0
Running on the Treadmill	Max. Stance	0.6	0.7	1.8	0.228	0.3
	SD	0.4	0.6	1.8		0.2
	Max. Swing	-2.6	-4.2	-2.9	0.189	-3.2
	SD	0.1	1.4	2.0		0.5
	Total Rotation	3.1	5.0	4.6	0.252	3.5
	SD	0.3	1.4	2.0		0.6

[†]Max.= Maximum. The P-value was considered as P-value < 0.05.

Total knee rotation was also calculated in this study. The absolute knee rotation (without regarding its positive or negative signs) in the stance and swing phases were accumulated and called "total knee rotation". Table 5-33 shows the total knee rotation in the ACL-deficient and the control groups.

Walking on level ground

During walking on level ground, the subjects demonstrated to external rotation at the heel strike and reached the peak point around 1° to 2° at about 30% of the gait cycle. Thereafter, the tibia internally rotated and reached -2° at 64% of the gait cycle, which was the toe-off point. It shortly reached its peak between -3° and -3.5° at around 75% of gait cycle. Then, it started to externally rotate and reached the neutral level in preparation for the next step. During walking on level ground, the ACL-deficient and the control subjects showed very similar knee rotation and no significant differences were found in the maximum stance, maximum swing or in total knee rotation. The rotation was reduced after either bracing or taping (Table 5-32).

Table 5-33 Results of t-tests of Knee Rotation during Walking on Level Ground.

T-tests (Knee Rotation)			
Walking on Level Ground	Max. in Stance	Max. in Swing	Total Rotation
Non-Paired T-Tests			
Normals vs. non-braced ACL	0.785	0.796	0.895
Normals vs. braced ACL	0.723	0.710	0.274
Normals vs. taped ACL	0.846	0.441	0.395
Paired T-Tests			
Non-braced ACL vs. braced ACL	0.952	0.180	0.454
Non-braced ACL vs. taped ACL	0.379	0.356	0.029

The statistical analyses showed no significant differences between the normal and the non-braced ACL-deficient subjects in terms of maximum knee rotation either in stance or in the swing phases ($P > 0.7$) (Table 5-33). Since there was no significant differences between the ACL-deficient and the control subjects, the brace or tape did not show any significant effect on knee rotation during walking on level ground. The graphs of knee rotation during walking on level ground have been shown in Figure 5-6.

Walking on the Treadmill

The results of t-tests of knee rotation during walking on the treadmill are as follows.

Table 5-34 Results of t-tests of Knee Rotation during Walking on the Treadmill:

T-tests (Knee Rotation)			
Walking on the treadmill	Max. in Stance	Max. in Swing	Total Rotation
Non-Paired T-Tests			
Normals vs. non-braced ACL	0.026	0.079	0.010
Normals vs. braced ACL	0.264	0.950	0.152
Normals vs. taped ACL	0.582	0.099	0.011
Paired T-Tests			
Non-braced ACL vs. braced ACL	0.142	0.664	0.187
Non-braced ACL vs. taped ACL	0.317	0.822	0.861

A repeated measure ANOVA test (Table 5-32) showed no significant differences within the ACL-deficient subjects in terms of maximum knee rotation in stance or swing phases when all supports were compared together.

The Non-braced ACL-deficient subjects showed significantly higher degrees of knee rotation in the both stance and particularly in the swing phases. Table 5-32 shows that the difference between the experimental and the control groups reached a significant level in total knee rotation mainly in the stance phase ($P=0.01$, $P=0.026$, respectively) during walking on the treadmill. However, when the ACL-deficient subjects used the FKB, there were no significant differences in knee rotation between the non-braced ACL-deficient and the control subjects, showing the restrictive effect of bracing in reduction of knee rotation. In the swing phase, the non-braced ACL-deficient subjects showed much greater knee rotation, but the difference was not significant ($P=0.079$). The bracing (and not taping) could remarkably reduce the knee rotation in the braced ACL-deficient subjects during walking on the treadmill. The results of knee rotation during walking on the treadmill have been shown as graphs in Figure 5-6.

Running on the Treadmill

The knee rotation parameters were also tested during running on the treadmill. The non-braced ACL-deficient subjects showed a greater knee rotation when compared to the control subjects (Table 5-32). T-tests (Table 5-35) showed a non-significant difference between the non-braced ACL-deficient subjects and the control subjects in terms of

maximum knee rotation in stance, swing and total knee rotation during running on the treadmill. Bracing significantly reduced knee rotation, mainly in the stance phase. Taping, however, even increased the maximum knee rotation during the stance phase but reduced it in swing. In terms of total knee rotation, the difference was significant between the non-braced ACL-deficient and control subjects. Either the brace or the tape could reduce the total knee rotation mainly in the stance phase when compared to the control subjects. The reduction was significant only when a FKB was used ($P=0.016$ changed to $P=0.212$). However, the reduction was not significant when the non-braced ACL-deficient subjects were compared to the braced ACL-deficient or the taped ACL-deficient subjects.

Table 5-35 Results of *t*-tests of Knee During Running on the Treadmill.

T-tests (Knee Rotation)			
Running on the treadmill	Max. in Stance	Max. in Swing	Total Rotation
Non-Paired T-Tests			
Normals vs. non-braced ACL	0.057	0.074	0.016
Normals vs. braced ACL	0.123	0.088	0.212
Normals vs. taped ACL	0.029	0.691	0.157
Paired T-Tests			
Non-braced ACL vs. braced ACL	0.709	0.087	0.303
Non-braced ACL vs. taped ACL	0.462	0.691	0.935

Figure 5-8 "Knee Rotation" in the ACL-Deficient and Control Subjects.

Knee Rotation –Walking on Level Ground

Dark blue=Braced ACL, Pink=No-braced ACL, Yellow=Taped ACL, Light blue=Controls

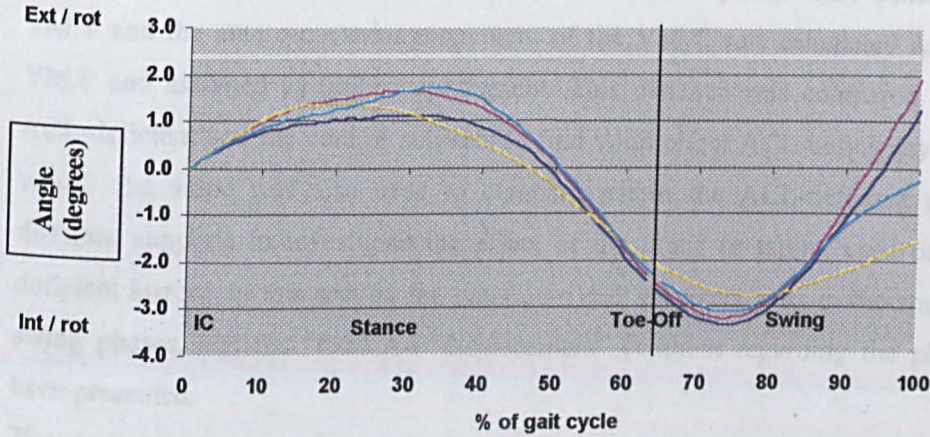

Knee Rotation –Walking on the Treadmill

Dark blue=Braced ACL, Pink=No-braced ACL, Yellow=Taped ACL, Light blue=Controls

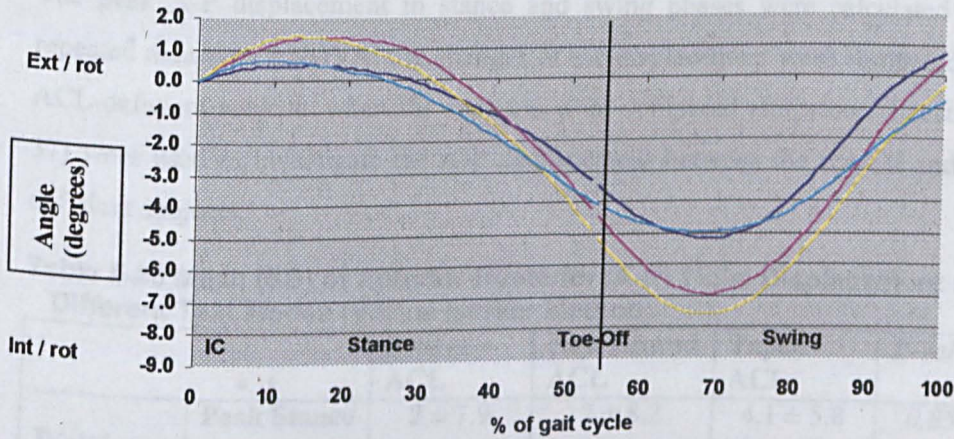

Knee Rotation –Running on the Treadmill

Dark blue=Braced ACL, Pink=No-braced ACL, Yellow=Taped ACL, Light blue=Controls

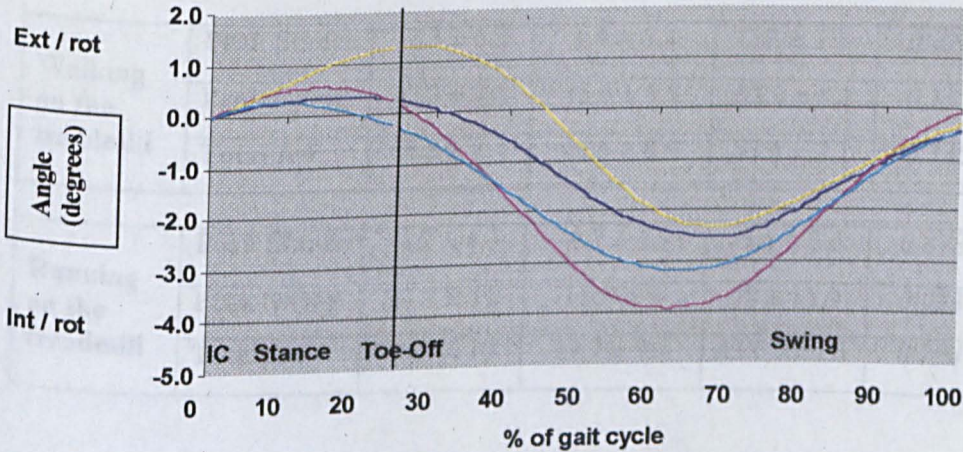

5.3.5. Anterior-Posterior (A-P) Tibial Translation

In this study, the sagittal movement (translation) of the tibia relative to the femur was studied using a virtual marker method. Two virtual markers were defined at the lower femoral epicondyle and the upper tibial plateau. These points were called VM.F and VM.T and the antero-posterior movement of the VM.T was calculated relative to the VM.F and assumed as tibial displacement. This distance was compared between the ACL-deficient and the control subjects to find what effect ACL-deficiency had on this value. The value was also used to compare within the ACL-deficient groups with different supports to investigate the effect of the brace or taping used on the ACL-deficient knees. In this section the maximum A-P displacements in the stance and the swing phases, and the "total A-P displacement" (without regarding the phases) have been presented.

The peak anterior-posterior (A-P) translatory movements of the tibial virtual marker (correspondence to the tibia) relative to the femoral virtual marker (correspondence to the femur) have been summarised in Table 5-36 and graphically illustrated in Figure 5-9. The peak A-P displacement in stance and swing phases were calculated and, using repeated measures ANOVA, the changes of the displacement were compared within the ACL-deficient subjects when the supports were compared altogether. T-tests (Table 5-37) were used to investigate the A-P displacement between the normal and the ACL-deficient subjects.

Table 5-36 Mean (SD) of Anterior-Posterior (A-P) Tibial Displacement during Different Test Modes (Virtual Marker Method).

		Braced - ACL	Non-Braced ACL	Taped - ACL	<i>P-value</i>	Controls
Walking on level ground	Peak Stance	2 ± 7.9	2 ± 8.2	4.1 ± 5.8	0.852	0 ± 3.7
	Peak Swing	46.8 ± 12.2	48.5 ± 12.4	55.9 ± 12.9	0.426	35.6 ± 5.9
	Total A-P	47.1 ± 17	50.1 ± 11.8	51.9 ± 12.4	0.832	35.6 ± 7
Walking on the treadmill	Peak Stance	-2.3 ± 6.5	1.4 ± 6.8	2.2 ± 5.1	0.426	-1 ± 4.3
	Peak Swing	42.3 ± 7.8	45.6 ± 9.9	52.4 ± 8.1	0.153	34.1 ± 8.3
	Total A-P	48.3 ± 8.4	46.5 ± 8.9	53.4 ± 7.1	0.345	38.4 ± 10.4
Running on the treadmill	Peak Stance	-4.2 ± 4.3	-4.7 ± 4.9	-5.4 ± 3.3	0.878	-4.4 ± 1.4
	Peak Swing	37.7 ± 11	35.9 ± 9	38 ± 11.9	0.923	27.3 ± 6.6
	Total A-P	39.4 ± 10	39.7 ± 9.4	43.6 ± 11.1	0.794	32.0 ± 6.6

Table 5-37 Results of t-tests of A-P Tibial Displacement during Different Test Modes.

T- Tests		Non-Paired T-tests			Paired T-test	
		Controls vs. Non-braced ACL	Controls vs. Braced ACL	Controls vs. Taped ACL	Non-braced ACL vs. Braced ACL	Non-braced ACL vs. Taped ACL
Walking on level ground	Peak Stance	0.54	0.52	0.12	0.94	0.21
	Peak Swing	0.02	0.03	0.001	0.48	0.08
	Total A-P	0.010	0.092	0.006	0.676	0.423
Walking on the treadmill	Peak Stance	0.41	0.66	0.20	0.01	0.99
	Peak Swing	0.030	0.08	0.001	0.06	0.09
	Total A-P	0.135	0.069	0.008	0.406	0.207
Running on the treadmill	Peak Stance	0.85	0.90	0.40	0.03	0.96
	Peak Swing	0.04	0.03	0.04	0.28	0.51
	Total A-P	0.065	0.036	0.013	0.689	0.079

Walking on Level Ground

Table 5-36 shows that the ACL-deficient subjects had greater anterior draw in both the stance and the swing phases during walking on level ground when compared to the control subjects. A repeated measure ANOVA showed no significant differences in the ACL-deficient subjects when all supports were compared altogether. However, a non-paired t-test (Table 5-37) showed a significant difference between the control subjects and all ACL-deficient groups with different supports only in the swing phase. During walking on level ground, the difference of A-P was not significant between the non-braced ACL-deficient and control groups in the stance phase ($P=0.54$), but it reached a significant level in the swing phase ($P=0.02$). The ACL-deficient subjects showed 36.2% greater A-P displacement relative to the control group in this level. When a FKB brace was used, although the A-P displacement was reduced 3.2%, the difference was still significant between the control and the braced ACL-deficient subjects ($P=0.03$). The difference became more significant when the ACL-deficient knees were taped

($P=0.004$) indicating that the A-P tibial displacement increased following the taping. The graphical information has been shown in Figure 5-7.

Walking on the Treadmill

Table 5-36 shows that a significant difference existed between the normal and the non-braced ACL-deficient subjects with different supports only in swing phase during walking on the treadmill ($P=0.03$). The ACL-deficient patients showed 33.7% greater A-P displacement relative to the normal subjects in swing. Following the bracing, the A-P value was reduced to 7.8% which was significant when compared with the control group (changed from $P=0.03$ to $P=0.08$) (Table 5-36). However, the value was not significant between the non-braced and the braced ACL-deficient subjects ($P=0.06$). Taping, again, even increased the A-P displacement during walking on level ground. Figure 5-9 shows the data as a graph.

Running on the Treadmill

During running on the treadmill, the ACL-deficient subjects showed 31.5% more A-P translation relative to the control group only in the swing phase ($P=0.04$). A non-paired t-test (Table 5-37) showed that there were significant differences in A-P tibial translation between the control and the ACL-deficient subjects only in the swing phase. Bracing could not significantly reduce the A-P displacements. Taping always increased the A-P tibial displacement and showed no restrictive effect. All the results have graphically been illustrated in Figure 5-9.

To further investigate the changes of the A-P tibial displacement in the ACL-deficient and control subjects and to find the effects of bracing or taping on it, the sum of the A-P tibial displacements during the stance and the swing phases were calculated and named as "total A-P tibial displacement".

During walking on level ground, there was a significant difference in the total tibial A-P translation between the non-braced ACL-deficient subjects and the control group ($P=0.010$). Wearing a FKB clearly reduced the displacement, so that the new displacement was not significantly different to that of the control subjects ($P=0.092$) indicating a significant restriction effect of the bracing. The taping, however, did not reduce the A-P displacements and the difference was still significant between the taped

ACL and the control group ($P=0.006$). Taping increased the total tibial translation in this level.

During running on the treadmill, the increased A-P displacement in the non-braced ACL-deficient subjects was obvious (24%↑), however, there was no significant difference between the non-braced ACL-deficient and the control subjects ($P=0.065$). A FKB did not significantly change the A-P displacement. Taping, conversely, increased the A-P displacement during running on the treadmill. Within the ACL-deficient groups, there were no significant differences in terms of total A-P tibial displacement ($P=0.794$).

Figure 5-9 "A-P Tibial Displacement" in the ACL-Deficient and Control Subjects.

A-P Tibial Translation –Walking on level ground

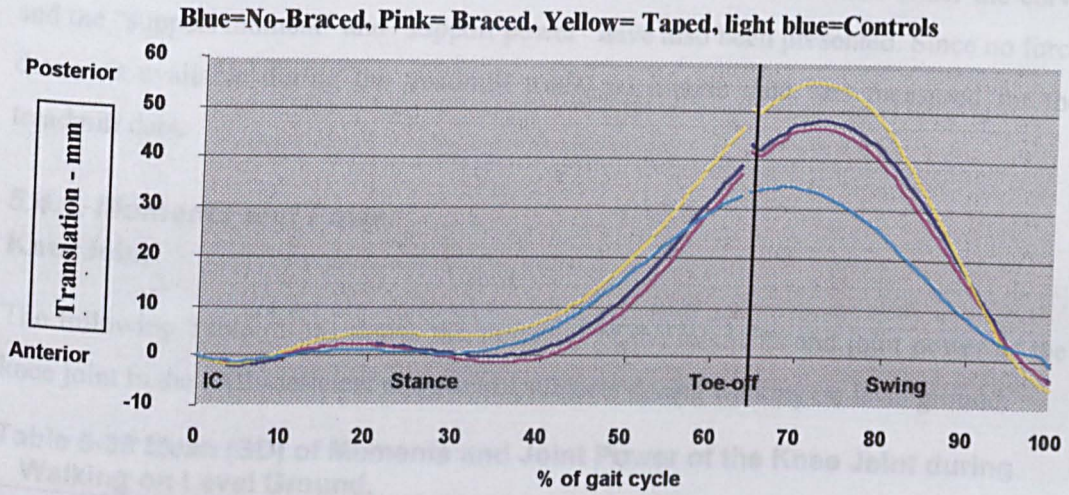

A-P Tibial Translation –Walking on the treadmill

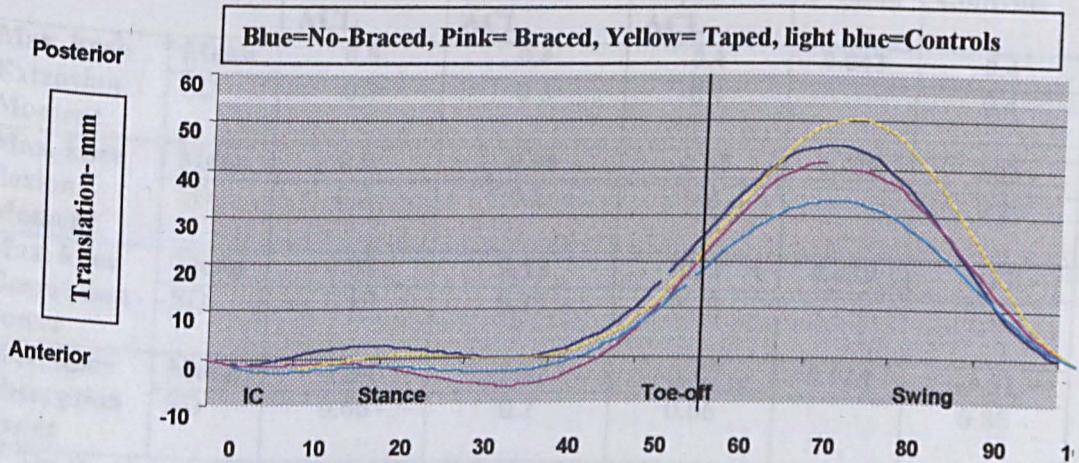

A-P Tibia Translation –Running on the treadmill

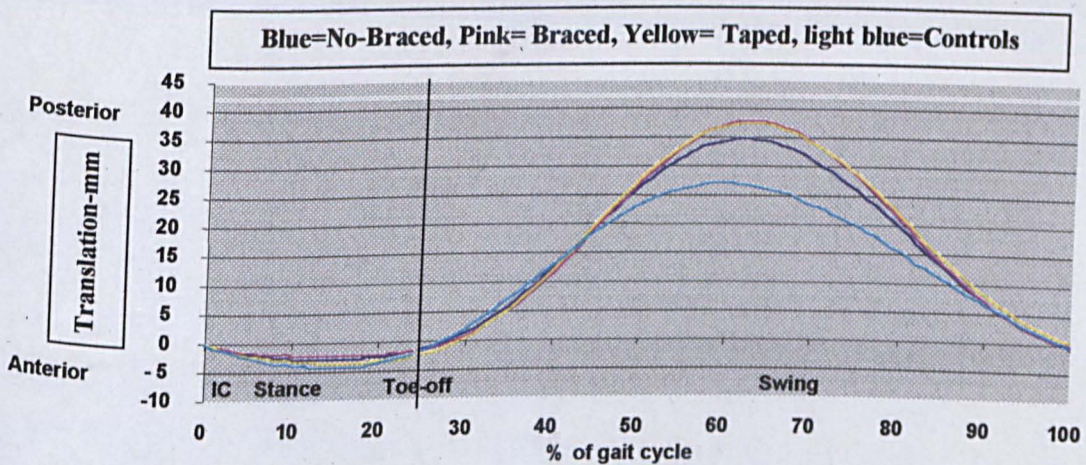

5.4. Kinetic Data Analysis

Summary of the moments and joint power generated at the knee, ankle and hip joints of the experimental and control groups during walking on level ground are given in Tables 5-38 to 5-43 and graphically shown in Figures 5-10 to 5-12. The areas under the curve and the "support moment" and "support power" have also been presented. Since no force data was available during the treadmill trials, no kinetic data was measured for the treadmill data.

5.4.1. Moments and Power

Knee Joint

The following Table (5-38) shows the summary of the moments and joint power of the knee joint in the ACL-deficient and control subjects during walking on level ground.

Table 5-38 Mean (SD) of Moments and Joint Power of the Knee Joint during Walking on Level Ground.

Knee Joint - Walking on Level Ground						
		Braced ACL	Non-Braced ACL	Taped ACL	<i>P-value</i>	Controls
Max. knee Extension Moment	Mean	0.5	0.4	0.4	0.943	0.4
	SD	0.2	0.3	0.4		0.4
Max. knee flexion Moment	Mean	0.0	-0.01	-0.05	0.765	0.03
	SD	0.2	0.2	0.2		0.2
Max. knee Generation Power	Mean	0.08	0.18	0.13	0.439	0.17
	SD	0.18	0.25	0.14		0.12
Max. knee Absorption Power	Mean	-1.34	-1.42	-1.47	0.913	-1.51
	SD	0.66	0.7	0.66		0.80

¹ The P-value was considered as P-value < 0.05

Table 5-39 Results of t-tests of Moments of the Ankle, Knee and Hip joints during Walking on Level Ground.

Moments	Max. Ankle D.F.	Max. Ankle P.F.	Max. Knee Ext.	Max. Knee Flexion	Max. Hip Ext.	Max. Hip Flexion
Non-paired t-test						
Normals vs. non-braced ACL	0.80	0.70	0.44	0.60	0.035	0.33
Normals vs. braced ACL	0.90	0.53	0.57	0.91	0.052	0.08
Normals vs. taped ACL	0.92	0.66	0.72	0.82	0.01	0.10
Paired t-test						
Non-braced ACL vs. braced ACL	0.59	0.06	0.28	0.73	0.92	0.02
Non-braced ACL vs. taped ACL	0.60	0.83	0.28	0.03	0.48	0.10

Max.= maximum, D.F.= dorsiflexion, P.F.= plantar flexion, Ext.= extension.

The maximum knee extension or flexion moments were very similar between the non-braced ACL-deficient and the control subjects. Repeated measure ANOVA and t-tests statistical analyses showed that there was no significant difference in moment between the control subjects and any of the ACL-deficient groups. No significant difference was found within the ACL-deficient groups when the supports were compared to each other. Adding a FKB or taping decreased the maximum knee extension moments, but the difference did not reach a significant level (Table 5-39).

Table 5-40 Results of t-tests of Joint Power of the Ankle, Knee and Hip joints during Walking on Level Ground.

Power	Max. Ankle Absorp. ¹	Max. Ankle Genera. ²	Max. Knee Absorp. ¹	Max. Knee Genera. ²	Max. Hip Absorp. ¹	Max. Hip Genera. ²
Non-paired t-test						
Non-braced normal vs. non-braced ACL	0.51	0.76	0.90	0.78	0.35	0.54
Non-braced normal vs. braced ACL	0.33	0.57	0.07	0.58	0.59	0.41
Non-braced normal vs. taped ACL	0.80	0.24	0.51	0.88	0.21	0.28
Paired t-test						
Non-braced ACL vs. braced ACL	0.14	0.40	0.07	0.51	0.64	0.77
Non-braced ACL vs. taped ACL	0.05	0.01	0.40	0.81	0.60	0.77

Absorp.¹=Absorption, Genera.²=Generation.

The maximum knee absorption power was less in the ACL-deficient knee subjects when compared to the control group. However, both groups showed very similar generation power. A non-significant difference was found in maximum knee generation power within the ACL-deficient groups with different supports ($P=0.439$). Wearing a FKB reduced the knee generation power within the ACL-deficient groups but the difference was not significant ($P=0.07$). Taping had no effects on knee power (Table 5-40).

Ankle Joint

The average ankle dorsi and plantar flexion moments as well as absorption and generation power during walking on level ground have been presented in Table 5-41.

Table 5-41 Mean (SD) of Moments and Joint Power of the Ankle Joint during Walking on Level Ground.

Ankle Joint - Walking on level ground						
		Braced ACL-def.	Non-Braced ACL-def.	Taped ACL-def.	P-value	Controls
Max. Ankle dorsi Flexion Moment	Mean	-0.06	-0.06	-0.06	0.992	-0.07
	SD	0.14	0.11	0.15		0.13
Max. Ankle Plantar Flexion Moment	Mean	0.99	1.12	1.13	0.532	1.07
	SD	0.31	0.28	0.30		0.28
Max. Ankle Generation Power	Mean	1.92	2.06	2.23	0.608	2.34
	SD	0.68	0.70	0.67		1.13
Max. Ankle Absorption Power	Mean	-0.62	-0.58	-0.72	0.707	-0.52
	SD	0.41	0.40	0.37		0.40

¹ The P-value was considered as P-value < 0.05

The ankle dorsiflexion moment was very similar between the ACL-deficient and the control subjects. However, the ankle plantar flexion moment was different between the non-braced and braced ACL-deficient subjects, although the difference was not significant ($P=0.06$) (Table 5-42). There was no significant difference between the non-braced ACL and taped ACL or between non-braced ACL and normals ($P=0.83$, $P=0.53$, respectively). A repeated measure ANOVA showed no significant differences within the ACL-deficient subjects with different supports in terms of maximum ankle dorsiflexion or maximum ankle plantar flexion moments when the supports were compared together ($P>0.5$) (Table 5-41). The ankle generation power was less in the ACL-deficient subjects

relative to the control groups. But the difference was not significant ($P=0.76$) (Table 5-39). Wearing a FKB reduced it, but taping increased it non-significantly. The non-braced ACL-deficient subjects showed greater ankle absorption power than the control subjects. Using either the brace or the tape increased the maximum ankle absorption power.

The statistical analysis showed that there was a non-significant difference in power of the ankle joint (both generation and absorption power) between the normal and the non-braced ACL-deficient subjects. Within the ACL-deficient groups, the braced ACL-deficient subjects showed less generation but more absorption power than that of the non-braced ACL-deficient subjects, which was not significant in either absorption or generation values ($P>0.05$). Taping, however, significantly increased both generation and absorption power in the taped ACL-deficient subjects when compared to the non-braced ACL-deficient subjects ($P=0.05$, $P=0.01$, respectively) (Table 6-40).

Figures 5-10, 5-11 shows the graphic illustration of the ankle joint moments and power.

In summary, the non-braced ACL-deficient subjects showed less absorption knee but more absorption ankle power than those seen in the control subjects.

Hip Joint

The average hip flexion and extension moments as well as absorption and generation power during walking on level ground have been presented in Table 5-42.

Table 5-42 Mean (SD) of Moments and Joint Power of the Hip Joint during Walking on Level Ground.

Hip Joint - Walking on level ground						
		Braced ACL	Non-Braced ACL	Taped ACL	<i>P-value</i>	Controls
Max. Hip Extension Moment	Mean	1.21	1.20	1.14	0.914	1.63
	SD	0.47	0.40	0.30		0.48
Max. Hip Flexion Moment	Mean	-0.97	-1.10	-1.01	0.598	-1.24
	SD	0.31	0.30	0.23		0.35
Max. Hip Generation Power	Mean	0.55	0.50	0.48	0.890	0.65
	SD	0.46	0.33	0.21		0.38
Max. Hip Absorption Power	Mean	-0.77	-0.79	-0.76	0.981	-0.90
	SD	0.39	0.48	0.26		0.33

¹ The P-value was considered as $P\text{-value} < 0.05$

The results of the moments in the hip joint showed that the maximum extensor moments generated at the hip were lower in the ACL-deficient groups than in the control group. The mean moment was 1.63 Nm/Kg in the controls. This contrasts with values of 1.20

Nm/Kg, 1.21 Nm/Kg and 1.14 Nm/Kg in the non-braced, braced, and taped ACL-deficient subjects, respectively. These differences were statistically significant ($P=0.035$) (Table 5-42). Consequently, the ACL-deficient subjects had less hip flexion moments than the control group. But this difference was not significant ($P=0.33$) When the ACL-deficient subjects used a FKB, the maximum hip extensor moments increased and consequently the maximum hip flexion moment decreased. This led to a non-significant difference only in maximum hip extensor moment between the braced ACL-deficient and the control subjects ($P=0.052$). Taping had no effects on maximum hip extension and the difference remained significant following the taping ($P=0.01$) (Table 5-39). In terms of power, the ACL-deficient subjects showed less hip generation and absorption power, which again were not significant in any of the test groups. In summary, the bracing or taping had no significant effects on the hip joint generation or absorption power. All numerical and graphic values have been shown in Table 5-42 and Figures 5-10 and 5-11.

“Support Moment” and “Support Power”

The sum of the ankle, knee and hip joint moments and power were calculated in the lower limb of the ACL-deficient and the control subjects and called “support moment” and “support power”. Table 5-43 showed that the sum of moments in the lower extremity was lower in the ACL-deficient subjects than that of the control subjects. Bracing decreased the “support moment”, but taping showed no effects on the total lower limb’s moments.

In terms of the “support power” in the lower limb, the normal subjects showed more generation power while the ACL-deficient subjects showed more absorption power. Both bracing and taping conditions increased the absorption power in the lower limb of the ACL-deficient subjects. All of the data has numerically been presented in Table 5-43 and graphically in Figure 5-10.

Figure 5-10 "Moments" of the ACL-Deficient and Control Subjects.

Moments - Ankle Joint - During Walking on Level Ground.

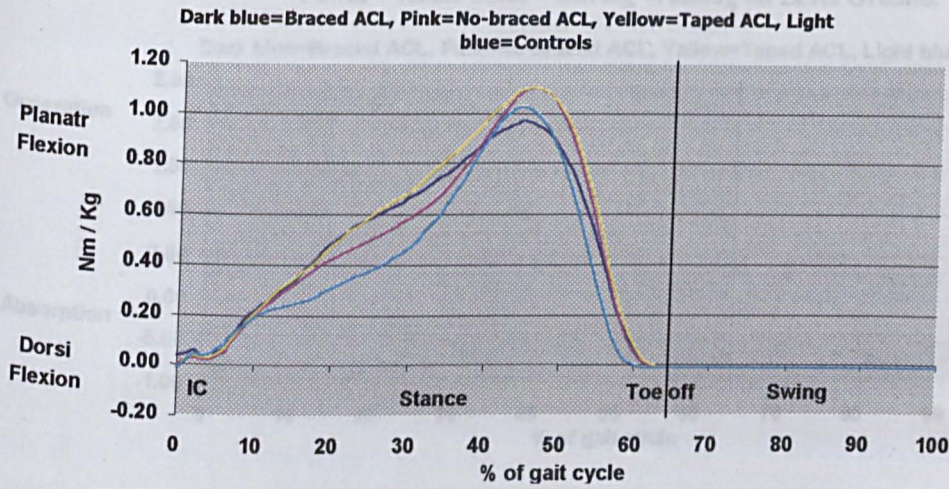

Moments - Knee Joint - During Walking on Level Ground
Dark Blue= Braced ACL, Pink=Non-Braced ACL, Yellow=Taped ACL, Light Blue=Controls

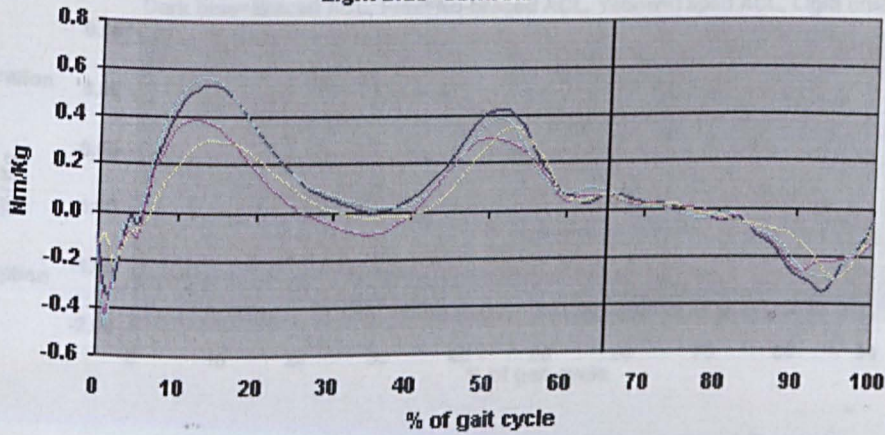

Moments - Hip Joint - During Walking on Level Ground.

Dark blue=Braced ACL, Pink=No-braced ACL, Yellow=Taped ACL, Light blue=Controls

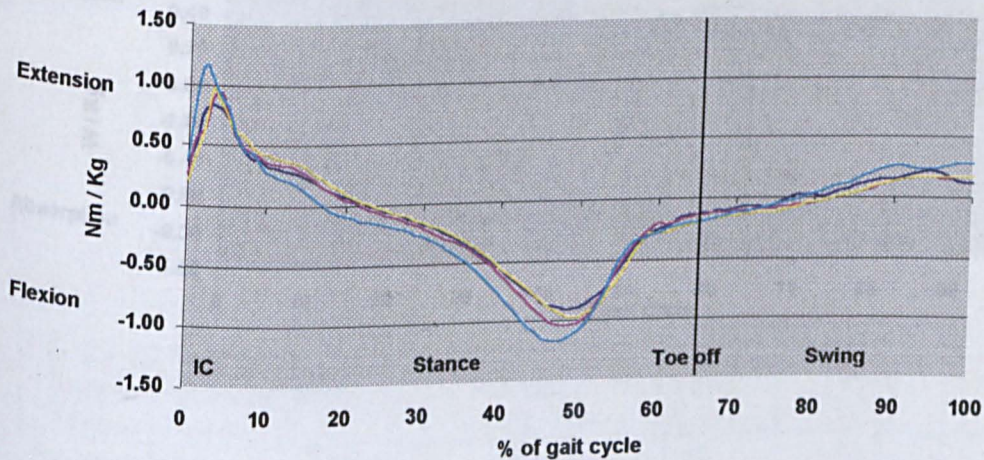
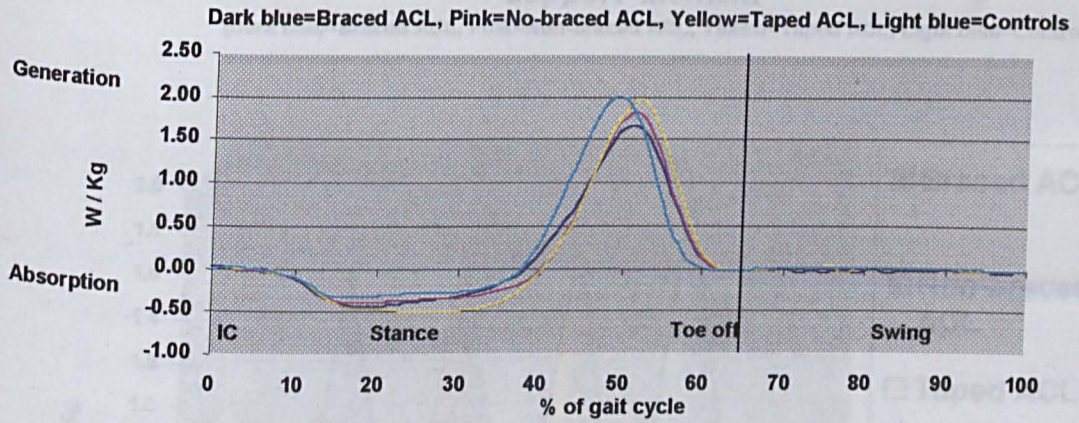
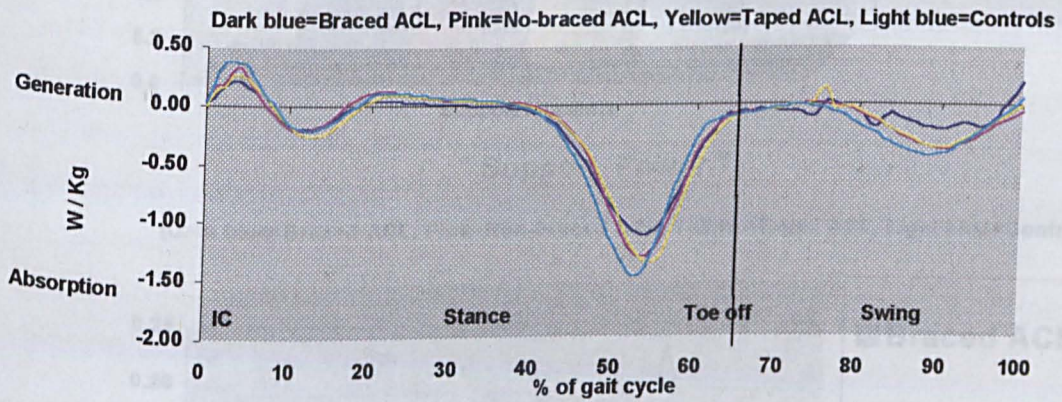

Figure 5-11 "Power" of the ACL-Deficient and Control Subjects.

Power – Ankle Joint – During Walking on Level Ground.



Power – Knee Joint – During Walking on Level Ground.



Power – Hip Joint – During Walking on Level Ground.

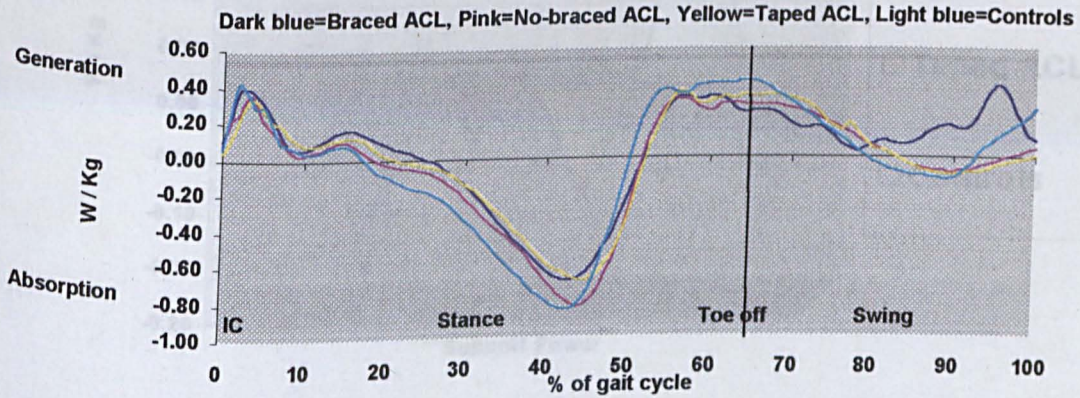

Table 5-43 Results of "Support Moment" and "Support Power".

	Braced ACL	No-braced ACL	Taped ACL	Controls
Support Moment	1.50	1.62	1.62	1.85
Support Power	-0.18	-0.05	-0.11	0.21

Figure 5-12 "Support Moment" and "Support Power" in the ACL-Deficients and the Control Subjects.

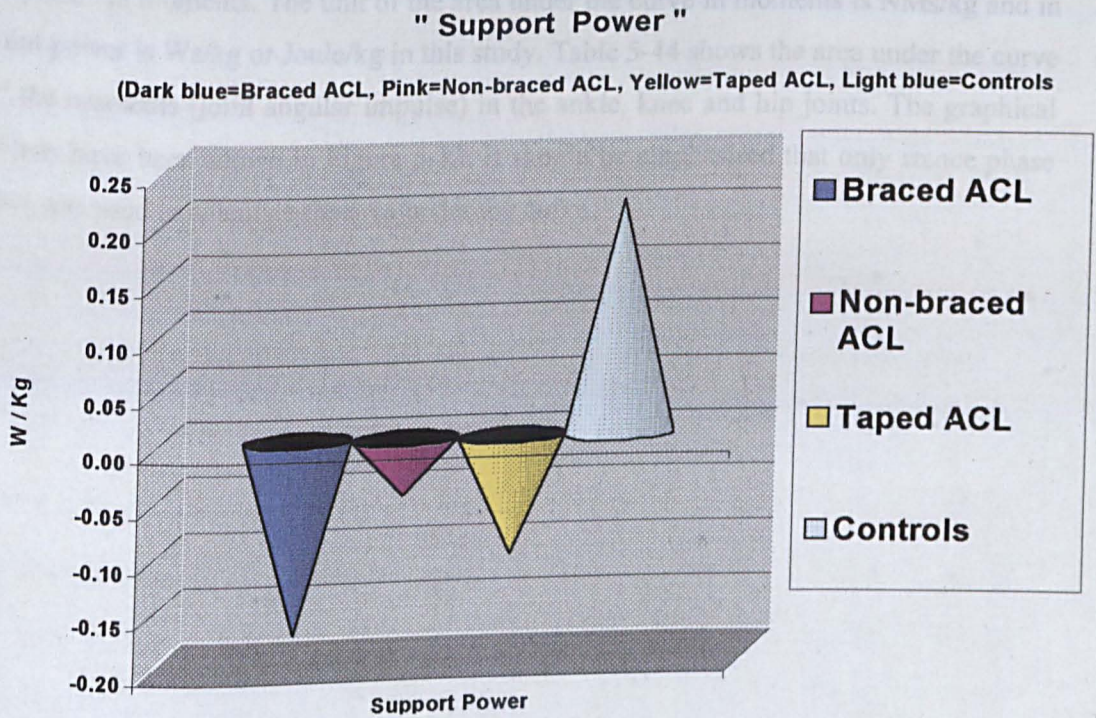
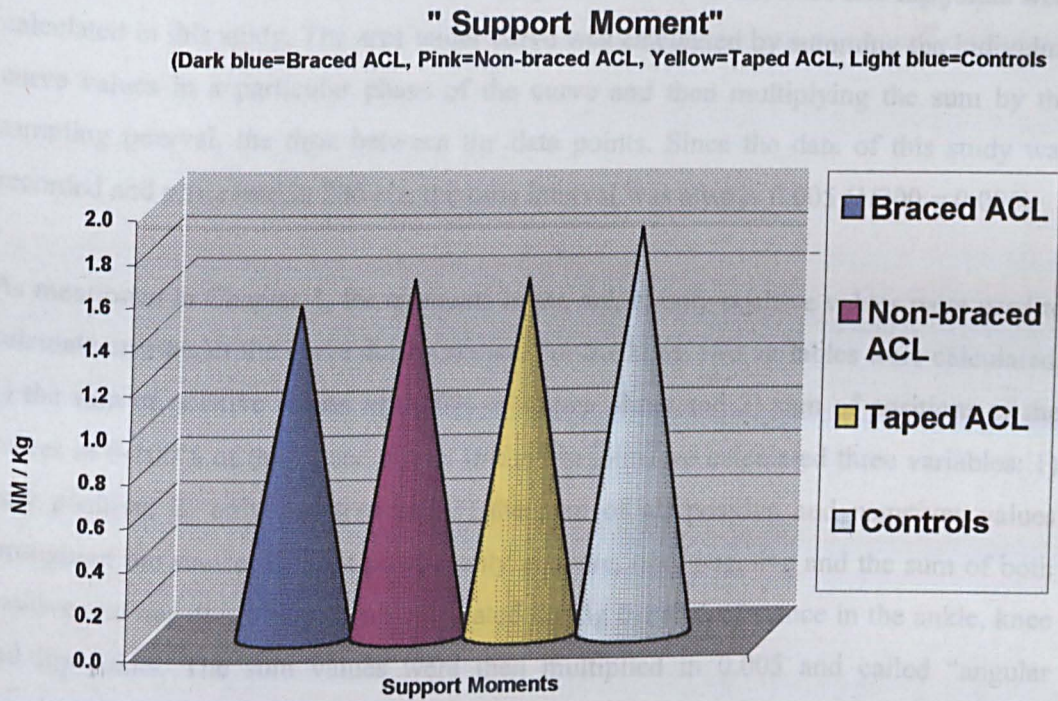

Table 5-43 Results of "Support Moment" and "Support Power".

"Support Moment" and "Support Power"		Braced ACL	Non-braced ACL	Taped ACL	Controls
Support Moment	Mean	1.50	1.62	1.62	1.85
Support Power	Mean	-0.18	-0.05	-0.11	0.21

Area under the Curve (AuC)

The area under the curve for moments and power of the ankle, knee and hip joints were calculated in this study. The area under curve was calculated by summing the individual curve values in a particular phase of the curve and then multiplying the sum by the sampling interval, the time between the data points. Since the data of this study was recorded and processed in 200 Hz, the time interval was always 0.005 ($1/200 = 0.005$).

As mentioned in Chapter 3, for moments in the ankle, only positive values were used to calculate area under the curve during stance. For the knee, two variables were calculated: 1) the sum of positive values in 0-50% of stance phase and 2) sum of positions of the values in 0-100% of the stance phase. In the hip joint, we calculated three variables: 1) only positive, 2) only negative and 3) the sum of all positive and negatives values throughout the stance. In joint power, only positive, only negative and the sum of both positive and negative values were calculated during 0-100% of stance in the ankle, knee and hip joints. The sum values were then multiplied in 0.005 and called "angular impulse" in moments. The unit of the area under the curve in moments is NMs/kg and in joint power is Ws/kg or Joule/kg in this study. Table 5-44 shows the area under the curve of the moments (joint angular impulse) in the ankle, knee and hip joints. The graphical values have been shown in Figure 5-13. It should be emphasised that only stance phase data was used to calculate the area under the curve.

Area under the Curve (AuC) – Moments (Angular Impulse)

The angular impulse variables of the ankle, knee and hip joints during walking on the ground have been presented in Table 5-44. Table 5-45 shows the results of t-tests in the angular impulse variables.

Table 5-44 Mean (SD) of the Area under the Curve of Moments in the Ankle, Knee and Hip Joints during Walking on Level Ground.

Summary Table of Areas Under the Curve					
MOMENTS	Braced ACL	Non-Braced ACL	Taped ACL	<i>P</i> value	Controls
Ankle - Moments (0 – 100%)- only positive values	0.16	0.16	0.18	0.853	0.14
SD	0.07	0.06	0.07		0.06
Knee - Moments (0 – 100%)-only positive values	0.06	0.07	0.07	0.885	0.07
SD	0.04	0.05	0.05		0.05
Knee - Moments (0 – 50%)-only positive values	0.02	0.03	0.04	0.481	0.03
SD	0.02	0.03	0.03		0.03
Hip - Moments (0 – 100%)- All positive & negative values	-0.05	-0.06	-0.08	0.924	-0.08
SD	0.05	0.05	0.05		0.05
Hip - Moments (0 – 100%)-only positive values	0.05	0.05	0.05	0.913	0.05
SD	0.02	0.03	0.03		0.02
Hip - Moments (0 – 100%)-only negative values	-0.09	-0.10	-0.12	0.841	-0.12
SD	0.04	0.04	0.03		0.04

¹ The P-value was considered as P-value < 0.05, ACL-def.= ACL-deficient

Table 5-45 Results of t-tests of Moments of the Ankle, Knee and Hip Joints during Walking on Level Ground.

T-Tests - Moments						
	Ankle	Knee		Hip		
Non-paired t-tests	All (+)	0-100% (+)	0-50% (+)	All (+/-)	Only (+)	Only (-)
Normals vs. braced ACL	0.383	0.631	0.373	0.177	0.891	0.098
Normals vs. non-braced ACL	0.367	0.861	0.992	0.332	0.786	0.248
normals vs. taped ACL	0.159	0.953	0.720	0.173	0.528	0.135
Paired t-tests						
Non-braced ACL vs. braced ACL	0.874	0.655	0.134	0.262	0.724	0.123
Non-braced ACL vs. taped ACL	0.013	0.579	0.598	0.042	0.340	0.308

Table 5-44 shows that in the ankle joint, the ACL-deficient subjects had more angular impulse values than that of the control subjects (14%) and using a FKB did not change this value. The difference between the normal and the ACL-deficient groups was not significant in terms of the ankle angular impulse throughout the stance phase ($P>0.05$) (Table 5-45). However, within the ACL-deficient groups, in spite of its non-significant level in all three conditions ($P=0.853$) (Table 5-44), the taped ACL-deficient subjects had significantly greater ankle angular impulse than the non-braced ACL-deficient subjects ($P=0.013$).

In the knee joint, in spite of a reduction in knee angular impulse during the first half of stance in only braced (and not taped) groups, no significant differences were found in the 0-50% or 0-100% of the stance phase between the ACL-deficient groups and the control subjects.

In the hip joint, opposed to the ankle joint, the ACL-deficient subjects showed 25% less area in the 0-100% of the stance phase (25% less). Calculation of the area under curve in all positive and negative values throughout the stance phase showed no differences within the ACL-deficient groups ($P>0.8$) when the supports were compared altogether. However, the taped ACL-deficient subjects showed a significantly greater hip moment area under curve throughout the stance phase when compared to the non-braced ACL-deficient subjects ($P=0.042$) (Table 5-45).

Figure 5-13 Histograms Showing the Average Moment's "Area Under the Curve" (Angular Impulse).

The mean of Joint Angular Impulse in Ankle Joint (0-50%)
(Dark blue=Braced ACL, Pink=No-braced ACL, Yellow=Taped ACL, Light blue=Control subjects)



The mean of Joint Angular Impulse in Ankle Joint (0-100%)
(Dark blue=Braced ACL, Pink=No-braced ACL, Yellow=Taped ACL, Light blue=Control subjects)



The mean of Joint Angular Impulse in Knee Joint (0-100%)
(Dark blue=Braced ACL, Pink=No-braced ACL, Yellow=Taped ACL, Light blue=Control subjects)

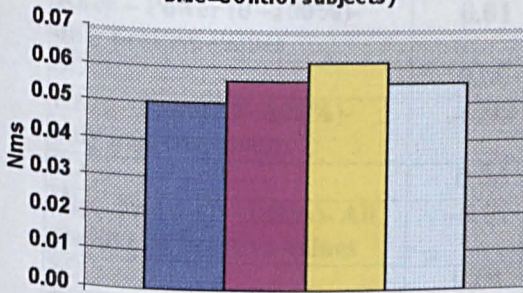

The mean of Joint Angular Impulse in Knee Joint (0-50%)
(Dark blue=Braced ACL, Pink=No-braced ACL, Yellow=Taped ACL, Light blue=Control subjects)

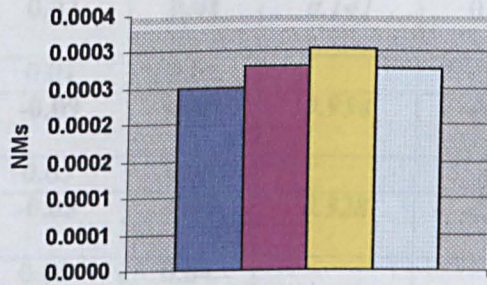

The mean of Joint Angular Impulse in hip Joint (0-100%)
(Dark blue=Braced ACL, Pink=No-braced ACL, Yellow=Taped ACL, Light blue=Control subjects)

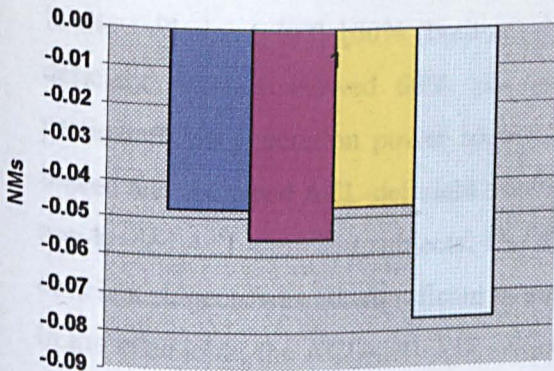

The mean of Joint Angular Impulse in hip Joint (0-50%)
(Dark blue=Braced ACL, Pink=No-braced ACL, Yellow=Taped ACL, Light blue=Control subjects)

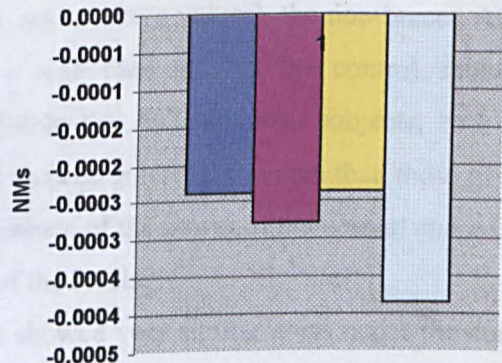

Area under the Curve (AuC) – Power

Table 5-46 shows the numerical values of the power area under curve in the ankle, knee and hip joints.

Table 5-46 Mean (SD) of the Area under Curve of Power in the Ankle, Knee and Hip Joints during Walking on Level Ground.

POWER	Braced ACL-def.	Non- braced ACL-def.	Taped ACL-def.	<i>P</i> value	Controls
Ankle - Power (0 -100%)- All positive & negative values	0.06	0.05	0.05	0.920	0.08
SD	0.03	0.03	0.04		
Ankle - Power (0 -100%)- only positive values	0.08	0.10	0.12	0.315	0.12
SD	0.09	0.04	0.04		
Ankle - Power (0 -100%)- only negative values	-0.05	-0.05	-0.07	0.429	-0.04
SD	0.03	0.03	0.03		
Knee - Power (0 -100%)- All positive & negative values	-0.07	-0.07	-0.07	0.902	-0.07
SD	0.04	0.04	0.04		
Knee - Power (0 -100%)- only positive values	0.01	0.02	0.01	0.141	0.02
SD	0.00	0.01	0.01		
Knee - Power (0 -100%)- only negative values	-0.08	-0.09	-0.09	0.954	-0.09
SD	0.04	0.05	0.04		
Hip - Power (0 -100%)- All positive & negative values	-0.01	-0.03	-0.02	0.528	-0.03
SD	0.04	0.04	0.04		
Hip - Power (0 -100%)- only positive values	0.05	0.04	0.05	0.813	0.05
SD	0.03	0.02	0.02		
Hip - Power (0 -100%)- only negative values	-0.06	-0.07	-0.06	0.656	-0.08
SD	0.03	0.03	0.03		0.03

[†]The P-value was considered as P-value < 0.05.

In the ankle joint, in 0-100% (both negative and positive values), the non-braced ACL-deficient subjects showed 60% less curve area than that of the control subjects, particularly in generation power section. Within the ACL-deficient subjects, both the braced and the taped ACL-deficient subjects showed greater curve area than those of the non-braced ACL-deficient subjects. The difference of the power in the normal and ACL-deficient subjects was not significant in any of the levels.

In the knee joint, the ACL-deficient subjects showed very similar areas under the curve relative to the control subjects and no significant differences were found between the normal and the ACL-deficient subjects or within the ACL-deficient groups throughout the stance phase. The braced ACL-deficient subjects showed significantly less knee

generation power than that of the non-braced ACL-deficient subjects in only the positive value area ($P=0.022$). Taping also reduced knee generation power although the difference was not significant ($P=0.059$) (Table 5-47).

In the hip joint, the area under curve in the non-braced ACL-deficient subjects was less than that of the control subjects (although non-significant). The FKB or taping significantly decreased it throughout the stance phase ($P<0.05$). In fact, it increased the area under curve in the positive phase (the first and the last part of the stance phase), and decreased it in the negative phase. In other words, the brace significantly decreased the absorption power areas ($P=0.015$) and increased the generation power. Taping also significantly decreased the power throughout the stance phase when compared with the non-braced ACL-deficient subjects ($P=0.024$). It also decreased the absorption power areas and increased the generation power areas, although the difference was not significant ($P=0.083$ and $P=0.418$, respectively).

Table 5-47 Results of t-tests of Power of the Ankle, Knee and Hip Joints during Walking on Level Ground.

POWER		Non-paired t-tests			Paired t-tests	
		Normals vs. braced ACL	Normals vs. non-braced ACL	Normals vs. taped ACL	Non-braced ACL vs. Braced ACL	Non-braced ACL vs. Taped ACL
Ankle	All (+/-)	0.143	0.108	0.092	0.838	0.566
	Only +	0.183	0.482	0.916	0.428	0.053
	Only -	0.399	0.378	0.057	0.986	0.039
Knee	All (+/-)	0.972	0.831	0.880	0.559	0.492
	Only +	0.100	0.602	0.246	0.022	0.059
	Only -	0.507	0.649	0.752	0.754	0.801
Hip	All (+/-)	0.398	0.946	0.544	0.058	0.024
	Only +	0.765	0.232	0.493	0.313	0.418
	Only -	0.190	0.595	0.216	0.015	0.083

5.5. Ground Reaction Force Data Analysis

The force parameters (seven parameters) recorded in this study are as following. The peak Vertical Impact Force (VIF_{peak}), the time to peak Vertical Impact Force (VIF_{time}), the area under curve in impact force (Impact Impulse), the Peak Vertical Active Force (VAF_{peak}), the time to Vertical Active Force (VAF_{time}) and the positive and negative peaks to the antero-posterior (medio-lateral) shear force (X_{+/-}). Summary statistics of force in the ACL-deficient and control subjects have been given in Table 5-48 and graphically illustrated in the Excel diagrams (Figures 5-14, 5-15).

Table 5-48 Mean (SD) of Impact and Anterior-Posterior Shear Force during Walking on Level Ground.

Summary Table of the Forces in All Subjects					
	ACL-def. Subjects			P-value	Controls
	Braced	Non-Braced	Taped		
VIF _{peak}	10.9	11.2	10.9	0.878	12.1
SD	1.3	1.9	1.4		0.8
VIF _{time}	13.3	13.6	13.6	0.857	12.8
SD	1.4	1.5	1.4		1.2
Impact Impulse	1.29	1.28	1.26	0.771	1.4
SD	0.1	0.1	0.1		0.1
VAF _{peak}	10.5	10.6	10.5	0.961	10.9
SD	1.1	1.0	0.9		0.8
VAF _{time}	46.8	46.5	46.7	0.894	46.4
SD	1.1	1.3	1.2		1.6
Peak X (+)	1.9	1.8	1.8	0.817	2.1
SD	0.5	0.6	0.5		0.4
Peak X (-)	-1.6	-1.7	-1.6	0.786	-2.0
SD	0.3	0.5	0.3		0.4

VIF_{peak} = Peak vertical impact force, VIF_{time} = Time to peak vertical impact force, VAF_{peak} = Peak vertical active force; VAF_{time} = Time to vertical active force; The P-value was considered as P-value < 0.05.

Table 5-49 Results of t-tests Analysis of Force during Walking on Level Ground.

T-TESTS	VIF peak	VIF time (%)	VAF peak	VAF time (%)	Peak X (+)	Peak X (-)	Impact Impulse
Non-Paired T-tests							
Normals vs. non-braced ACL-deficient	0.13	0.15	0.40	0.87	0.49	0.06	0.045
Normals vs. braced ACL-deficient	0.009	0.35	0.34	0.58	0.83	0.006	0.077
Normals vs. taped ACL-deficient	0.01	0.17	0.21	0.63	0.37	0.005	0.007
Paired t-tests							
Non-braced ACL vs. braced ACL-deficient	0.34	0.37	0.60	0.62	0.03	0.43	0.339
non-braced ACL vs. Taped ACL-deficient	0.36	0.77	0.41	0.59	0.73	0.36	0.191

The P-value was considered as P-value < 0.05

5.5.1. Vertical (Impact) Force

The non-braced ACL-deficient subjects showed a lower VIF_{peak} and a longer VIF_{time} than those of the control subjects. The VIF_{peak} was reduced after either bracing or taping. A repeated measure ANOVA revealed that neither the brace nor the tape could significantly change any of the variables in force data when all supports were compared altogether (Table 5-48). However, t-tests (Table 5-49) showed that the differences between the VIF peak reached to a significant level after either bracing or taping ($P=0.009$, $P=0.01$, respectively) indicating that both the brace and the tape conditions significantly reduced the VIF_{peak} in the ACL-deficient subjects.

Indeed, the significantly greater VIF_{time} in non-braced ACL-deficient subjects showed a delay in starting to walk in this group. No significant differences were found in the peak of vertical active force in terms of either the magnitude (VAF_{peak}) or the starting time of walking (VAF_{time}).

The area under curve of the impact force (Impact Impulse) in the normal and ACL-deficient subjects showed that the ACL-deficient subjects had 8.6% smaller impact impulse than that of the control subjects. The differences within the ACL-deficient groups were not significant when all groups were compared altogether ($P=0.771$). However, t-tests (Table 5-49) revealed that the difference of the impact impulse force reached a significance level between the normal and the non-braced ACL-deficient subjects ($P=0.045$). Wearing a FKB significantly increased the impact impulse, so that the new difference of the impact impulse was non-significant between the braced ACL-deficient and the control subjects ($P=0.077$). This difference, however, was not significant when the braced ACL-deficient subjects were compared with the non-braced ACL-deficient subjects. Taping, however, could not change the impact impulse values and the difference remained significant between the taped ACL-deficient and the control subjects ($P=0.007$).

5.5.2. Anterior-Posterior shear Force

The repeated measure ANOVA analysis showed no significant differences within the ACL-deficient subjects in terms of magnitude of the positive or negative peak of the anterior-posterior force (both $P>0.05$) (Table 5-48). However, the difference of the negative part of anterior-posterior force vector (posterior part) was significant between the control and the braced or taped ACL-deficient patients ($P=0.006$, $P=0.005$,

respectively). This difference indicates that either bracing or taping significantly reduced the peak posterior (aft) force value in the patients. This value, however, did not significantly change when the braced or taped ACL-deficient subjects were compared with the non-braced ACL-deficient subjects.

Figure 5-14 Force Graphs During Walking on Level Ground.

Vertical (impact) force during walking on level ground.

Dark blue = Braced ACL, Pink = No-braced ACL, Yellow = Taped ACL, Light blue = Controls

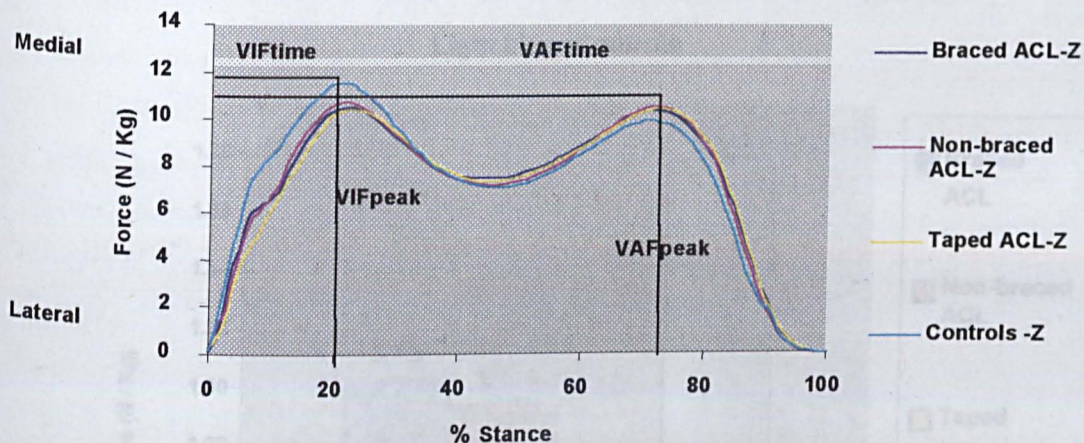

Lateral-Medial Shear force during walking on the ground.

Dark blue=Braced ACL, Pink=No-braced ACL, Yellow=Taped ACL, Light blue=Controls

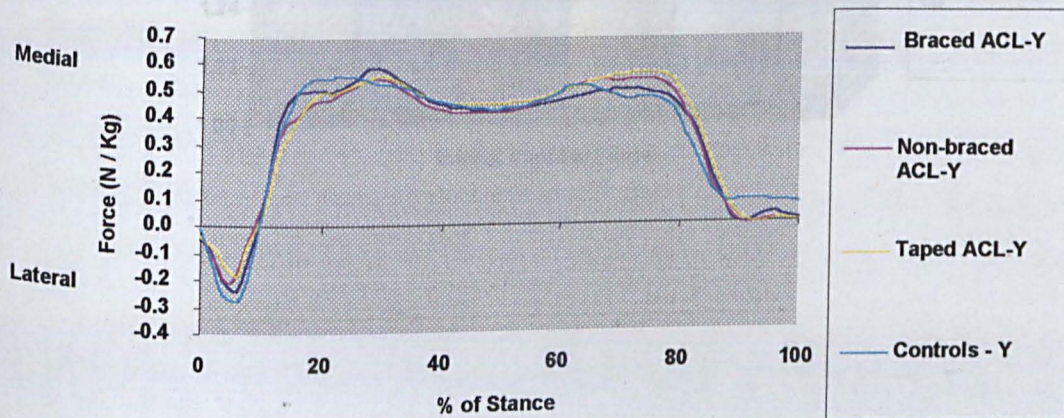

Anterior-Posterior shear force during walking on the ground.

Dark blue=Braced ACL, Pink=No-braced ACL, Yellow=Taped ACL, Light blue=Controls

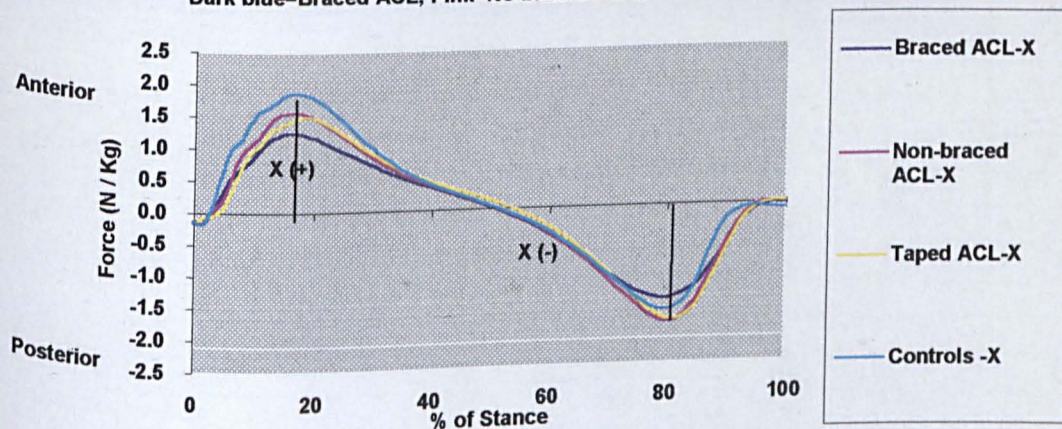

Figure 5-15 "Impact Impulse" during Walking on Level Ground.

Dark blue=Braced ACL, Pink=Non-braced ACL, Yellow=Taped ACL

Light blue=Controls

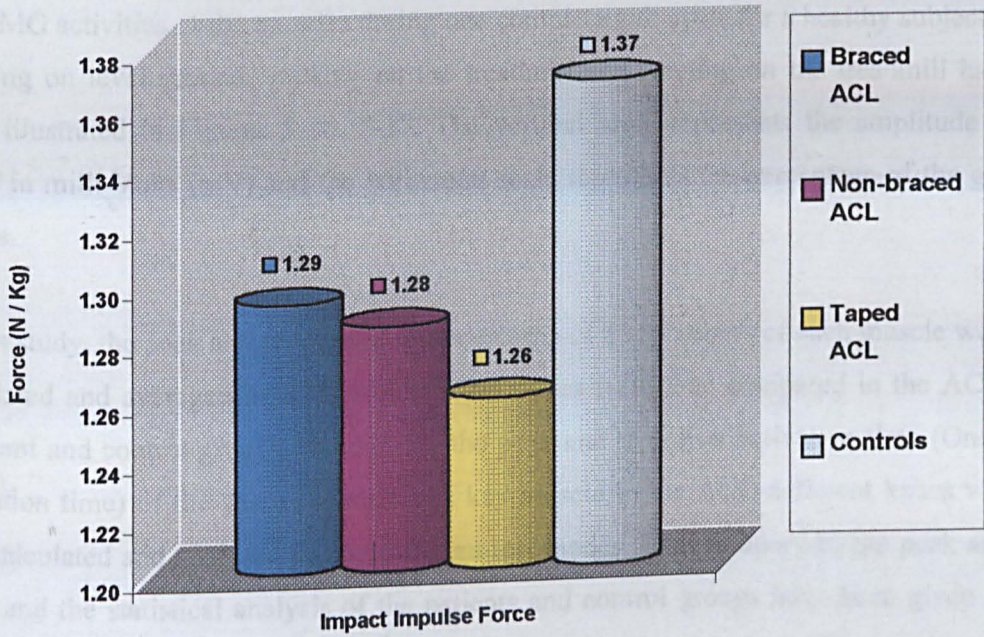

Table 5-50 "Peak" Values of EMG during Different Test Modes

Test Mode	Braced ACL	Non-Braced ACL	Taped ACL	P-value	Controls
Walking on level ground	101	95	81	0.871	97.3
Medialis	101	95	81	0.401	95.5
Gastrocnemius	101	95	81	0.573	97.1
Tennis	101	95	81	0.463	95.4
Hamstring	101	95	81		
Walking on the treadmill	101	95	81	0.231	97.4
Medialis	101	95	81	0.602	95.6
Gastrocnemius	101	95	81	0.703	98.9
Tennis	101	95	81	0.701	97.2
Hamstring	101	95	81		
Running on the treadmill	101	95	81	0.933	181.3
Medialis	101	95	81	0.083	273.2
Gastrocnemius	101	95	81	0.37	80.3
Tennis	101	95	81	0.279	85.5
Hamstring	101	95	81		

5.6. EMG Data Analysis

Myoelectrical activities were recorded from four muscles located around the knee joint by surface contact electrodes during different trials and were compared in different groups. The four muscles studied were the vastus medialis, rectus femoris, medial hamstring and gastrocnemius muscles. The peak and root mean square (RMS) of the EMG activities of the muscles during one complete gait cycle for a healthy subject in walking on level ground, walking on the treadmill and running on the treadmill have been illustrated in Figures 5-16, 5-17. The vertical scale represents the amplitude of EMG in milli-Volts (mV) and the horizontal scale represents the percentage of the gait cycles.

In this study, the peak and root mean square (RMS) of EMG curves of each muscle were calculated and averaged in each subject. The values were then compared in the ACL-deficient and control groups. In addition, the peak and the onset activation time (Onset activation time) of the gastrocnemius as a key muscle in the ACL-deficient knees was also calculated and analysed during different test modes. The summary of the peak and RMS and the statistical analysis of the patients and control groups have been given in Tables 5-50 to 5-51. Some typical graphs of EMG in the control and the non-braced ACL-deficient subjects during walking and running tests have been shown in Figure 5-18.

Table 5-50 "Peak" Values of EMG during Different Test Modes.

EMG – Peak Value	Braced ACL	Non-Braced ACL	Taped ACL	<i>P-value</i> ¹	Controls
Walking on level ground					
Vastus Medialis	74.1	66.5	64.1	0.871	97.3
Gastrocnemius	90.9	93.8	72.4	0.404	86.8
Rectus Femoris	39.2	39.4	23.4	0.575	64.1
Medial Hamstring	51.1	63.6	44	0.466	58.4
Walking on the treadmill					
Vastus Medialis	84.9	55	52.7	0.238	82.4
Gastrocnemius	85	85.4	73.7	0.662	64.6
Rectus Femoris	33	30.6	25.6	0.763	38.9
Medial Hamstring	40.3	42.6	33.8	0.761	52.2
Running on the treadmill					
Vastus Medialis	219.7	202.7	214.5	0.958	181.3
Gastrocnemius	207.3	207.5	192.3	0.933	223.2
Rectus Femoris	92.1	74.6	82.4	0.57	84.3
Medial Hamstring	74.2	99.2	67.8	0.279	88.5

¹The P-value was considered as P-value < 0.05

Table 5-51 "Root Mean Square (RMS)" Values of EMG during Different Test Modes.

EMG – RMS Value	Braced ACL	Non-Braced ACL	Taped ACL	<i>P-value</i> ¹	Controls
Walking on level ground					
Vastus Medialis	30.5	25.9	26.5	0.765	41.4
Gastrocnemius	36.1	37	29	0.335	37.2
Rectus Femoris	18.6	18.2	12.5	0.521	28.8
Medial Hamstring	23	26.2	20	0.513	28.9
Walking on the treadmill					
Vastus Medialis	29.3	22.4	21.1	0.37	31.7
Gastrocnemius	37.7	37.9	32.8	0.692	30.2
Rectus Femoris	15.5	15	13.4	0.853	16.8
Medial Hamstring	19.6	19.5	17.7	0.893	24.6
Running on the treadmill					
Vastus Medialis	83.5	92.1	80.5	0.904	72.5
Gastrocnemius	92.9	103.1	90.1	0.805	98
Rectus Femoris	37.4	37	37	0.996	35.5
Medial Hamstring	35	45.8	33	0.18	41.8

¹ The P-value was considered as P-value < 0.05.

Some differences were detected in peak or RMS in the muscles studied between the ACL-deficient and the control groups. During walking on level ground, the activities of the quadriceps muscles (both the vastus medialis and the rectus femoris) were less in the ACL-deficient subjects than that of the control group, although it was not significant. The gastrocnemius and the hamstring muscles, however, showed a higher activity in the non-braced ACL-deficient subjects. Bracing reduced hamstring activity (20%) and increased vastus medialis activity (11%). The activity of the gastrocnemius muscle was not changed following bracing. After the taping, the amount of activity of all of the four muscles was non-significantly reduced. The repeated measure ANOVA showed that neither in the peak nor in the RMS values did the ACL-deficient subjects show any significant differences in any of the investigated muscles when all supports were compared together.

To have a better comparison of the muscles' peak and RMS between the ACL-deficient and control groups, the t-test analyses were also carried out and the results have been presented in Table 5-52.

Table 5-52 Results of t-tests of EMG Parameters in Different Muscles During Walking on Level Ground.

Walking on level ground								
Non-paired T-tests	Vastus Medialis		Gastrocnemius		Rectus Femoris		Med. Hamstring	
	Peak	RMS	Peak	RMS	Peak	RMS	Peak	RMS
Normals vs. braced ACL	0.431	0.308	0.857	0.920	0.311	0.286	0.739	0.571
Normals vs. non-braced ACL	0.326	0.176	0.748	0.985	0.264	0.225	0.834	0.797
Normals vs. taped ACL	0.256	0.158	0.520	0.382	0.025	0.028	0.518	0.401
Paired T-tests								
Non-braced ACL vs. Braced ACL	0.607	0.395	0.640	0.624	0.974	0.843	0.261	0.353
Non-braced ACL vs. Taped ACL	0.678	0.468	0.171	0.144	0.230	0.196	0.149	0.151

Table 5-52 shows that none of the difference in the peak or RMS of the four studied muscles reached a significant level during walking on level ground. The only significant change occurred in the rectus femoris muscle that was significantly reduced following the taping ($P < 0.03$). The rest of muscles showed very similar values either between the ACL-deficient and the control subjects or within the ACL-deficient subjects. Neither bracing nor taping could significantly change the values.

During walking on the treadmill, the quadriceps and hamstring muscles showed lower activities in the ACL-deficient subjects than those of the control group. The gastrocnemius muscles showed 23% more activity in the non-braced ACL-deficient subjects when compared to the control subjects. Following wearing a FKB, the activities of the quadriceps muscles increased (35%), the hamstring and the gastrocnemius muscle showed no differences in the amount of activation following knee bracing. The taping, however, similar to walking on level ground, reduced the activities of all four muscles.

The T-test results of peak and RMS findings of the EMG during walking on the treadmill are as following:

Table 5-53 Results of t-tests of EMG Parameters in Different Muscles during Walking on the Treadmill.

Walking on the treadmill								
Non-paired T-tests	Vastus Medialis		Gastrocnemius		Rectus Femoris		Med. Hamstring	
	Peak	RMS	Peak	RMS	Peak	RMS	Peak	RMS
Normals vs. braced ACL	0.951	0.827	0.128	0.157	0.623	0.749	0.457	0.373
Normals vs. non-braced ACL	0.455	0.418	0.108	0.175	0.558	0.687	0.505	0.247
Normals vs. taped ACL	0.366	0.346	0.581	0.673	0.241	0.340	0.185	0.171
Paired T-tests								
Non-braced ACL vs. Braced ACL	0.285	0.200	0.603	0.891	0.748	0.438	0.908	0.449
Non-braced ACL vs. Taped ACL	0.336	0.575	0.225	0.300	0.352	0.269	0.045	0.101

The results of t-tests showed that the changes of neither the peak nor the RMS on the four studied muscles were significant between the control and ACL-deficient subjects or within the ACL-deficient subjects with different supports.

During running on the treadmill, the activities of all four muscles increased in the ACL-deficient subjects. The activities of the quadriceps muscles again increased after bracing (19%). The medial hamstring muscle showed a 25% reduction in muscle activity following a FKB and the gastrocnemius muscle remained with no changes in the amounts of muscle activity following knee bracing. The taping did not change the activity of the quadriceps, but reduced the activity of the gastrocnemius (7.5%) and the medial hamstring muscles.

The t-test results of EMG findings during running on the treadmill have been presented in the Table 5-54.

Table 5-54 Results of t-tests of EMG Parameters in Different Muscles during Running on the Treadmill.

Running on the treadmill								
Non-paired T-tests	Vastus Medialis		Gastrocnemius		Rectus Femoris		Med. Hamstring	
	Peak	RMS	Peak	RMS	Peak	RMS	Peak	RMS
Normals vs. braced ACL	0.539	0.647	0.724	0.821	0.724	0.864	0.538	0.431
Normals vs. non-braced ACL	0.745	0.531	0.747	0.842	0.675	0.858	0.685	0.661
Normals vs. taped ACL	0.581	0.715	0.589	0.737	0.930	0.821	0.438	0.389
Paired T-tests								
Non-braced ACL vs. Braced ACL	0.486	0.594	0.988	0.416	0.098	0.940	0.181	0.113
Non-braced ACL vs. Taped ACL	0.550	0.497	0.740	0.605	0.189	0.991	0.145	0.118

The t-tests revealed that the differences mentioned above were not significant between the ACL-deficient and control groups or within the ACL-deficient subjects in terms of either peak or RMS values.

In summary, no significant changes were found in the four studied muscles' peak or RMS between the ACL-deficient and control subjects. Neither bracing nor taping could significantly change the peak or RMS values within the ACL-deficient subjects with different supports.

Figure 5-16 "Peak" EMG of Knee Muscles during Trials on Different Test Modes.

Peak values - knee joint during walking on level ground.

Blue= With Brace, Red= Without Brace, Yellow= With tape, Light Blue= Controls

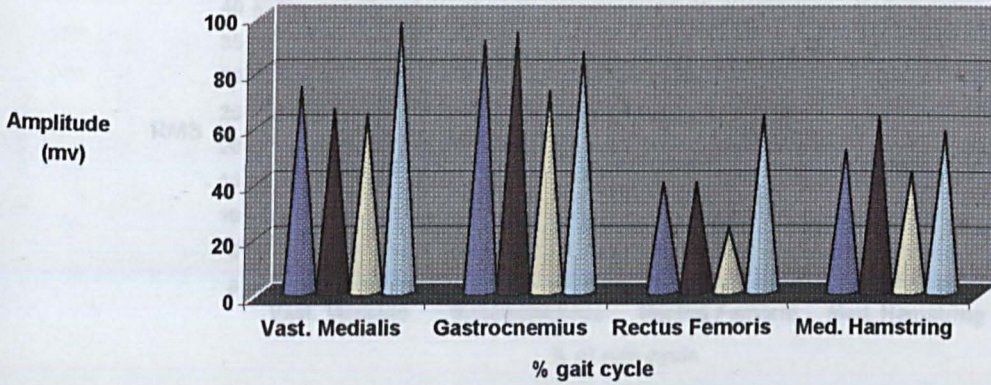

Peak values - knee joint - during walking on the treadmill.

Blue= With Brace, Red= Without Brace, Yellow= With tape, Light Blue= Controls

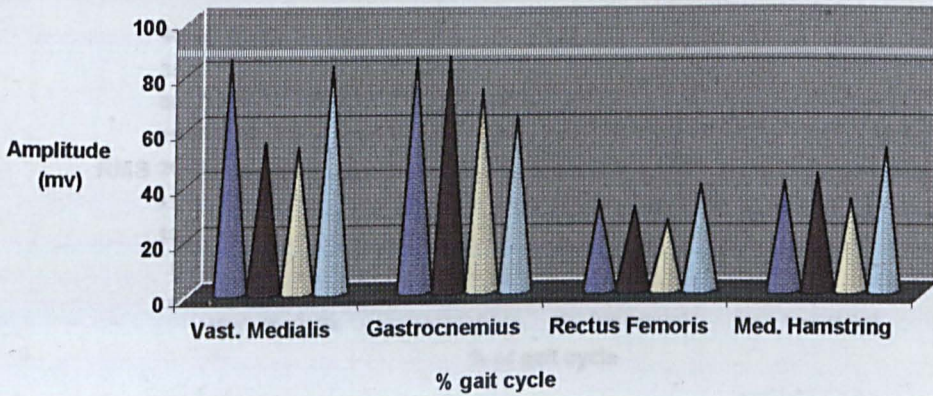

Peak values - knee joint - during running on the treadmill.

Blue= With Brace, Red= Without Brace, Yellow= With tape, Light Blue= Controls

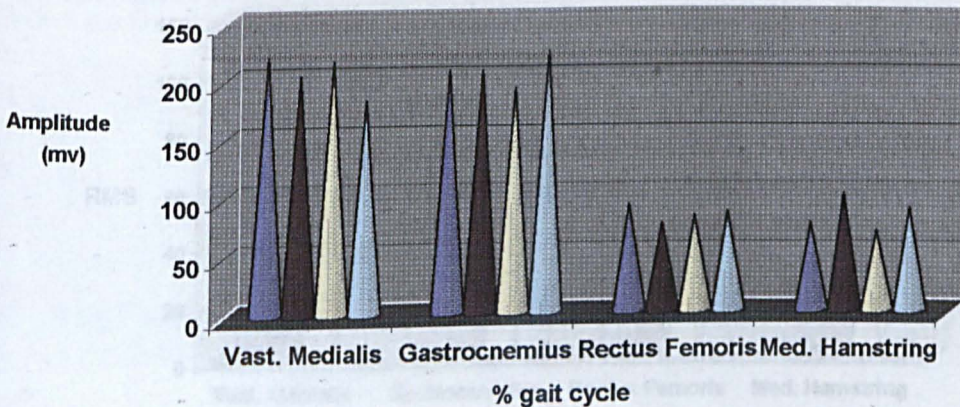
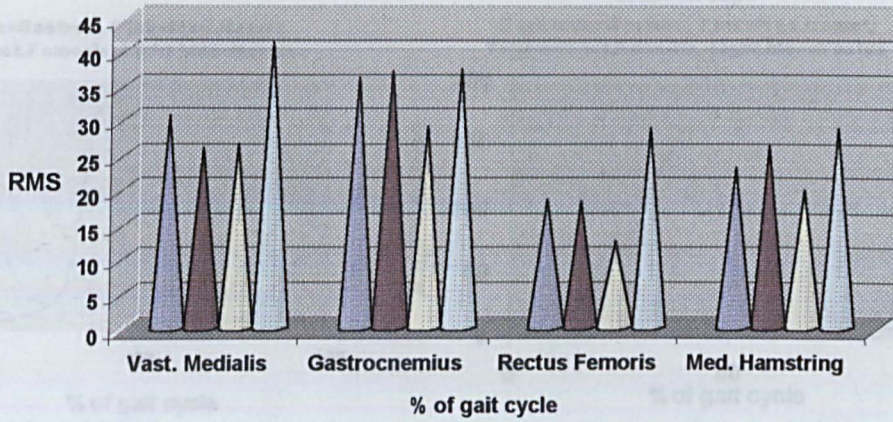

Figure 5-17 "RMS" EMG of Knee Muscles during Trials on Different Test Modes.

RMS – Knee Muscles – During walking on level ground.

Blue= With Brace, Red= Without Brace, Yellow= With tape, Light Blue= Controls



RMS – Knee Muscles – During walking on the treadmill

Blue= With Brace, Red= Without Brace, Yellow= With tape, Light Blue= Controls

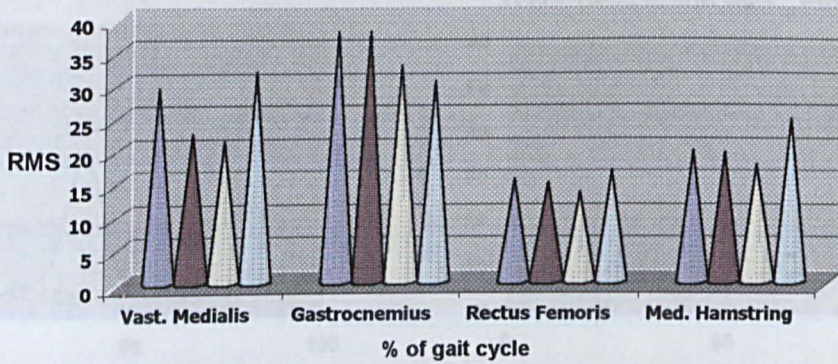

RMS – Knee Muscles – During running on the treadmill.

Blue= With Brace, Red= Without Brace, Yellow= With tape, Light Blue= Controls

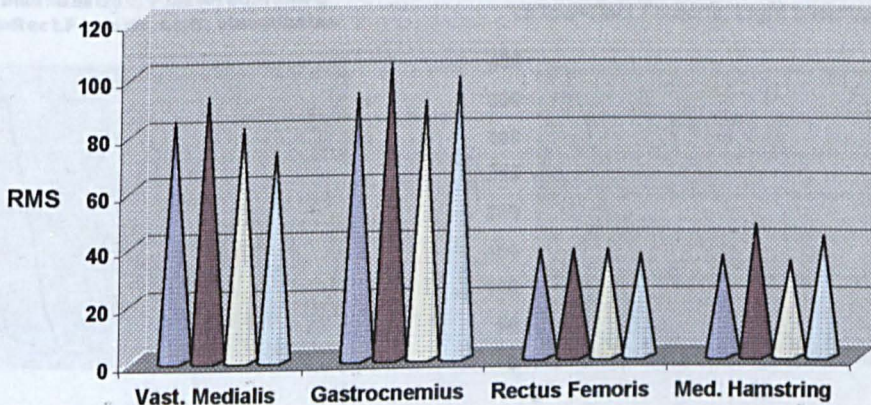
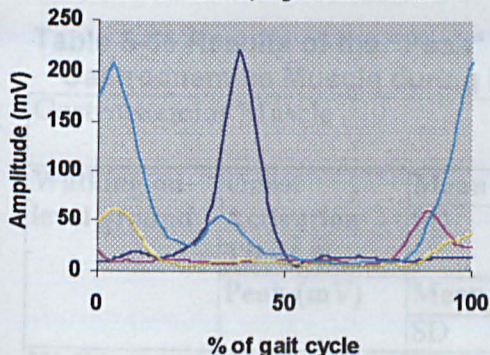

Figure 5-18 Typical "EMG Pattern" in a Non-Braced ACL-Deficient and a Control Subject in Different Test Modes.

Typical EMG in a "normal subject" during walking on the ground Without Brace or tape

Dark blue=Gastroc, Pink=Med.Hamst, Yellow=Rect.Femoris, Light blue=Vastus



Typical EMG in an "ACL-def. subject" during walking on the ground Without Brace or tape

Dark blue=Gastroc, Pink=Med.Hamst, Yellow=Rect.Femoris, Light blue=Vastus

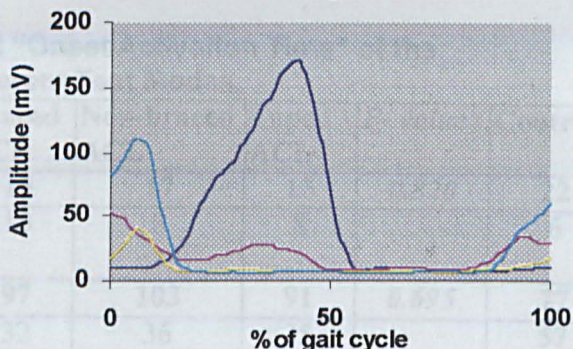

Typical EMG in a "normal subject" during walking on the treadmill Without Brace or tape

Dark blue=Gastroc, Pink=Med.Hamst, Yellow=Rect.Femoris, Light blue=Vastus

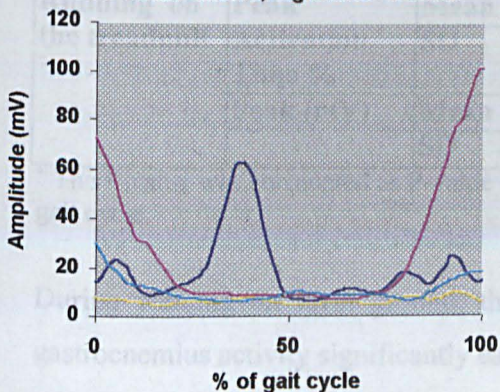

Typical EMG in a "ACL-def. subject" during walking on the treadmill Without Brace or tape

Dark blue=Gastroc, Pink=Med.Hamst, Yellow=Rect.Femoris, Light blue=Vastus

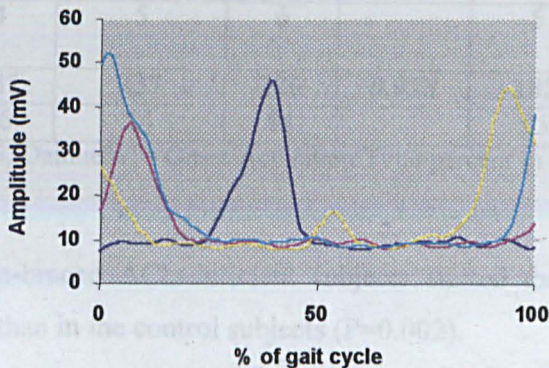

Typical EMG in a "normal subject" during Running on the treadmill Without Brace or tape

Dark blue=Gastroc, Pink=Med.Hamst, Yellow=Rect.Femoris, Light blue=Vastus

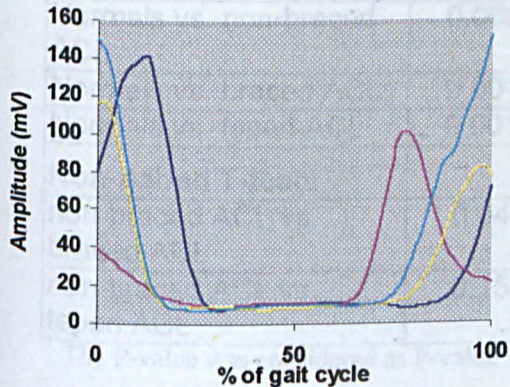

Typical EMG in an "ACL-def. subject" during Running on the treadmill Without Brace or tape

Dark blue=Gastroc, Pink=Med.Hamst, Yellow=Rect.Femoris, Light blue=Vastus

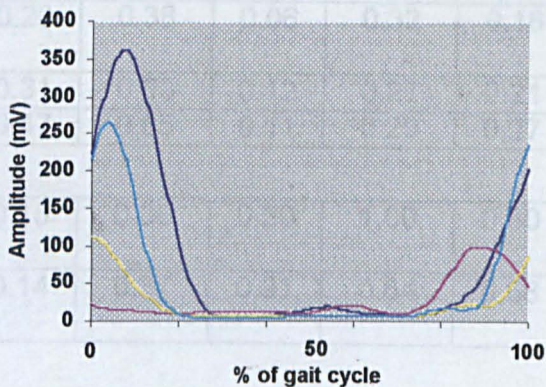

Gastrocnemius Muscle Activity in ACL-Deficient Knee

The peak and onset activation time of the gastrocnemius, as a principal muscle in ACL-deficient subjects, has also been studied before and after wearing a FKB or taping, and the related Tables (Table 5-55 to 5-56) and graphs were plotted. The graphs have been pictured in Figures 5-19 to 5-22.

Table 5-55 Results of the "Peak" and "Onset Activation Time" of the Gastrocnemius Muscle during Different Test Modes.

Gastrocnemius Muscle			Braced ACL	Non-braced ACL	Taped ACL	P-value ¹	Controls
Walking on level ground	Onset Activation Time ² %	Mean	15	17	15	0.820	22
		SD	10	8	8		6
	Peak (mV)	Mean	97	103	91	0.695	77
		SD	32	36	35		57
Walking on the treadmill	Onset Activation Time %	Mean	7	14	18	0.076	14
		SD	7	7	9		2
	Peak (mV)	Mean	92	97	85	0.954	73
		SD	38	42	37		32
Running on the treadmill	Peak Activation Time %	Mean	12	12	11	0.946	15
		SD	4	5	6		5
	Peak (mV)	Mean	231	237	226	0.958	182
		SD	76	84	84		95

¹ The P-value was considered as P-value < 0.05, Oatime%² = Onset Activation Time percent in a gait cycle.

During walking on level ground, the non-braced ACL-deficient subjects started the gastrocnemius activity significantly earlier than in the control subjects (P=0.002).

Table 5-56 Results of t-tests of the "Peak" and "Onset Activation Time" of the Gastrocnemius Muscle during Different Test Modes.

Non-Paired T-tests	Walking on level ground		Walking on the treadmill		Running on the treadmill	
	% Time	Peak	% Time	Peak	% Time	Peak
Normals vs. non-braced ACL	0.002	0.20	0.38	0.06	0.32	0.18
Normals vs. braced ACL	0.001	0.31	0.03	0.12	0.27	0.21
Normals vs. taped ACL	0.001	0.47	0.65	0.11	0.29	0.27
Non-paired T-tests						
non-braced ACL vs. braced ACL	0.04	0.15	0.36	0.30	1.00	0.80
non-braced ACL vs. taped ACL	0.15	0.14	0.37	0.91	0.64	0.58

¹ The P-value was considered as P-value < 0.05

When a FKB or taping was used, either the braced or the taped ACL-deficient subjects activated their gastrocnemius muscle significantly earlier and the differences were significant ($P=0.001$) (Table 5-56) indicating the positive effects of the brace or tape in Onset activation time of the muscle. However, either the FKB or the tape reduced the peak activity of the gastrocnemius muscle during walking on level ground in the ACL-deficient subjects ($P>0.05$), although the difference was not significant.

During walking on the treadmill, the braced ACL-deficient subjects significantly started earlier (50% earlier) the activity of the gastrocnemius muscle relative to the non-braced patients ($P=0.03$). The taping, however, could not change the Onset activation time in the gastrocnemius muscle during walking on the treadmill ($P=0.65$) when compared to the control subjects.

During running on the treadmill, there were no significant differences in the peak or Onset activation time of the gastrocnemius muscle in the ACL-deficient and the control subjects. No significant differences were found in the peak or Onset activation time in the gastrocnemius muscle before and after wearing either a FKB or taping during forceful activity.

5.6.1. Gastrocnemius Muscle and Different Movement Surfaces

Huge changes were found in the gastrocnemius muscle either in the peak or in the Onset activation time during different test modes. To study if the observed changes were correlated to the surfaces of movement, the effects of different surfaces (level ground and the treadmill) were investigated on the peak and the onset activation time of the gastrocnemius muscle. The correlation was studied either in the non-braced ACL-deficient or in the healthy subjects. The summary of the results and statistical analysis has been shown in Table 5-57.

Table 5-57 Results of t-tests of the Effects of Different Surfaces on the "Peak and "Onset Activation Time" of the Gastrocnemius Muscle.

T-tests	% time	Peak
Normals wk/gr. vs. normals-wk/tr.	0.003	0.649
Normals wk/tr. vs. normals-run/tr.	0.69	0.002
Normals wk/gr. vs. normals-run/tr.	0.003	0.008
Non-braced ACL wk/gr. vs. non-braced ACL-wk/tr.	0.37	0.11
Non-braced ACL wk/tr. vs. non-braced ACL-run/tr.	0.61	0.0002
Non-braced ACL wk/gr. vs. non-braced ACL-run/tr.	0.26	0.0001

¹ The P-value was considered as $P\text{-value} < 0.05$, wk/gr. = Walking on level ground, wk/tr. = Walking on the treadmill, run/tr. = Running on the treadmill, %time = onset activation time.

The values were individually studied in the non-braced ACL-deficient and control subjects. Table 5-57 revealed that when the data derived from walking on level ground was compared with those of walking on the treadmill, there was no significant difference in the normal subjects in terms of the peak activity of the gastrocnemius muscle. Regarding the onset activation time, however, the normal subjects started the gastrocnemius activity significantly earlier during walking on the treadmill relative to walking on level ground ($P=0.003$). During walking and running on the treadmill, no significant differences were found between these test modes in the healthy subjects in terms of the onset activation time, but the peak of the gastrocnemius activity was significantly higher during running on the treadmill in comparison with walking on the treadmill ($P=0.002$). In running on the treadmill and walking on level ground, however, there were significant differences in terms of either peak ($P=0.008$) or Onset activation time ($P=0.003$) in the healthy subjects. The same statistical analysis was applied to the non-braced ACL-deficient subjects.

In the non-braced ACL-deficient subjects during walking on level ground and walking on the treadmill, no significant differences were found either in peak or in Onset activation time ($P=0.11$, $P=0.37$, respectively). During walking on the treadmill and running on the treadmill, there was a significant difference only in peak value ($P=0.0002$) and not in the Onset activation time of the gastrocnemius muscle. During walking on level ground and running on the treadmill, there was a significant difference between the two surfaces only in peak value ($P=0.0001$) and not in the Onset activation time ($P=0.26$). This shows that the non-braced ACL-deficient subjects had an increased ankle plantar flexion angle either in walking on level ground or in running on the treadmill; and that the onset activation time was high enough in both conditions. Figure 5-20 to 5-22 show the graphical illustration of the peak onset activation time in the gastrocnemius muscle.

Figure 5-19 "Peak" and "Onset Activation Time" of the Gastrocnemius Muscle During Trials on Different Test Modes.

"Onset Activation Time"

Blue = Running on the treadmill, Pink = Walking on the ground, Yellow = Walking on the treadmill

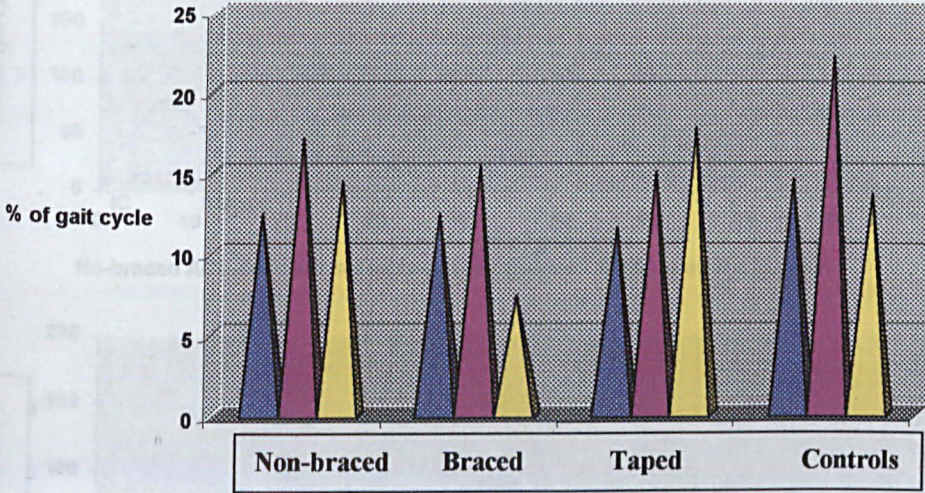

"Peak"

Blue = Running on the treadmill, Pink = Walking on the ground, Yellow = Walking on the treadmill

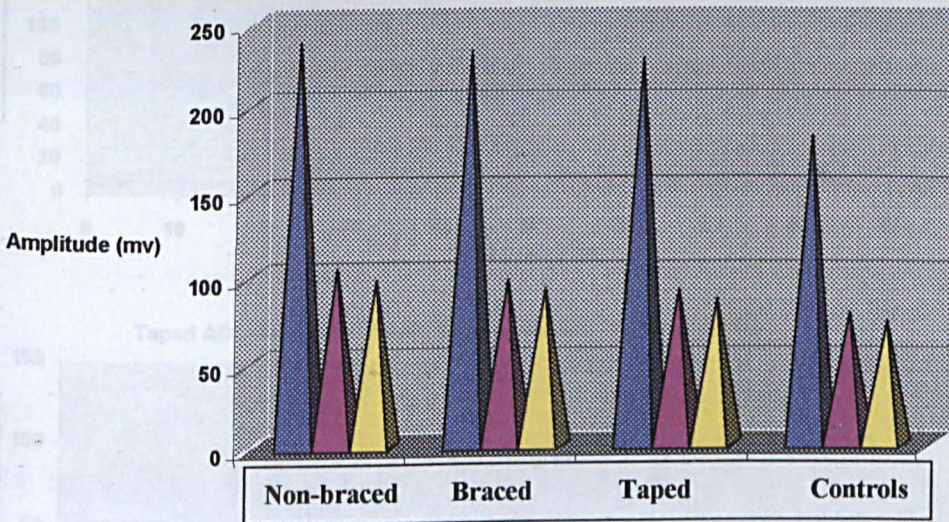

Figure 5-20 "Peak" and "Onset Activation Time" of the Gastrocnemius Muscle in Some ACL-Deficient and Control Subjects during Walking on Level Ground. [each colour shows a patients muscle activity].

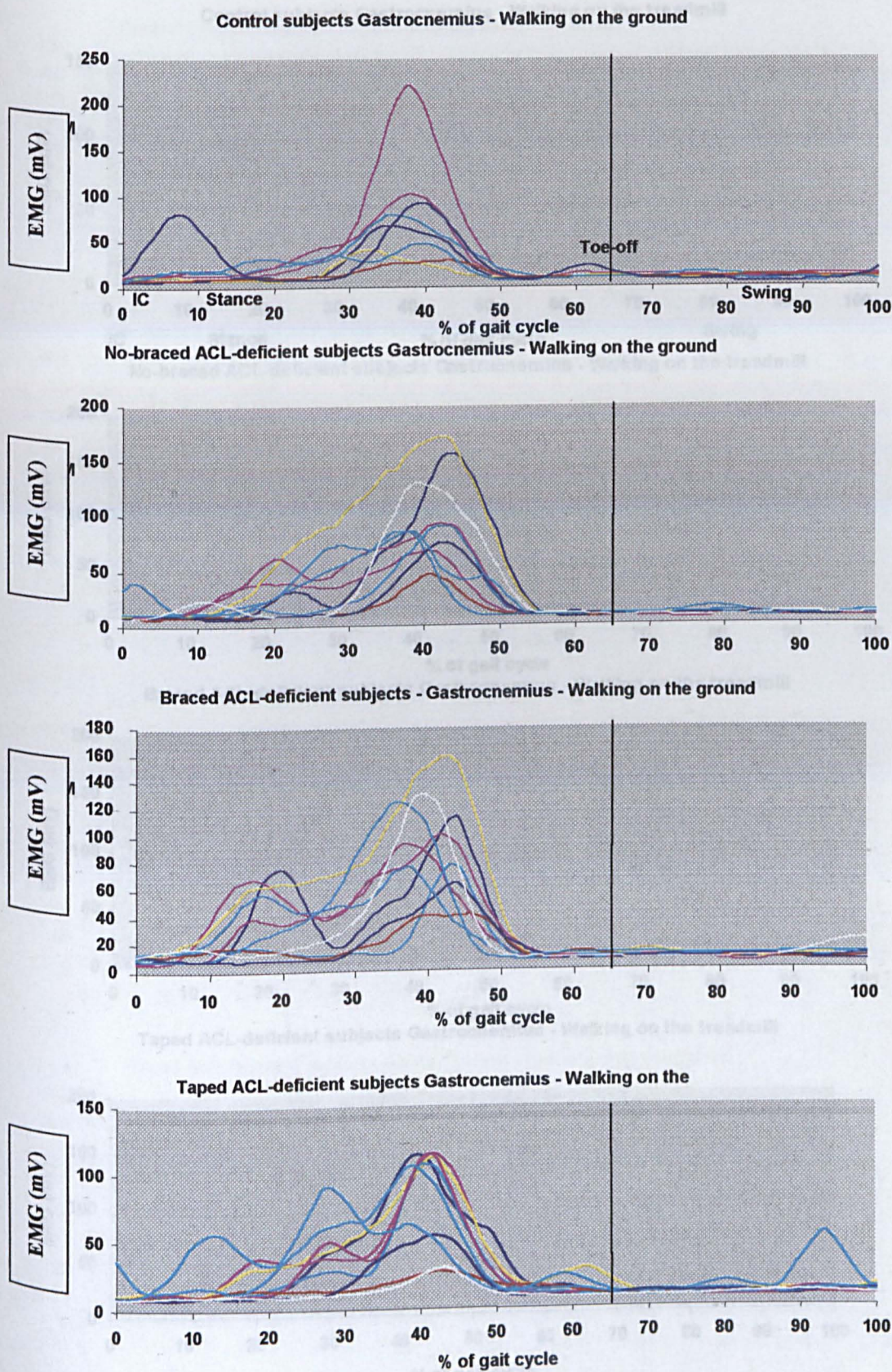

Figure 5-21 "Peak" and the "Onset Activation Time" of the Gastrocnemius Muscles in Some ACL-Deficient and Control Subjects during Walking on the Treadmill.

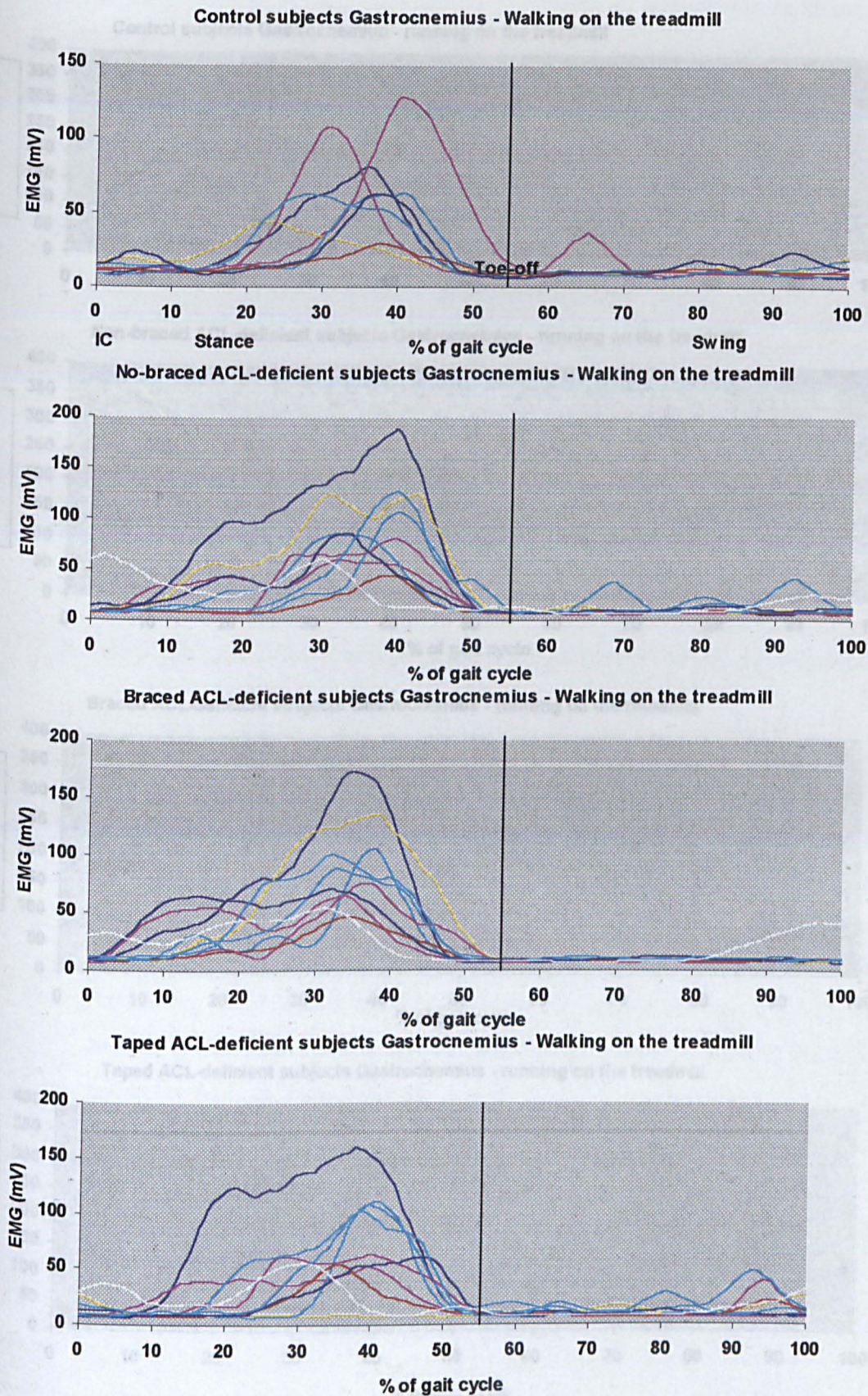
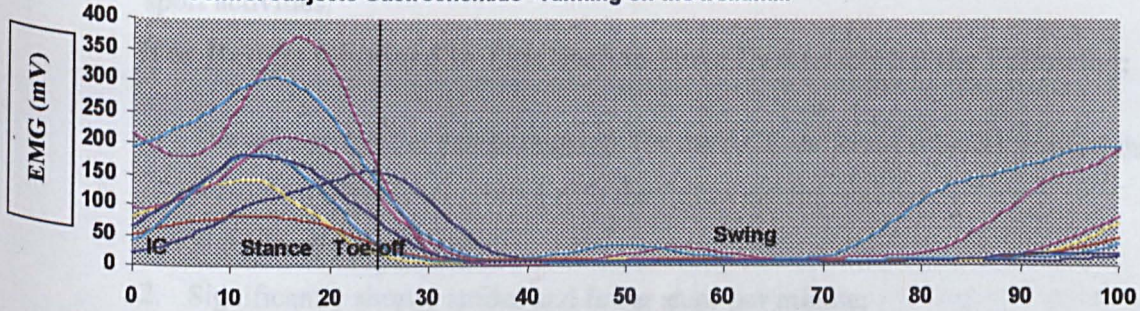
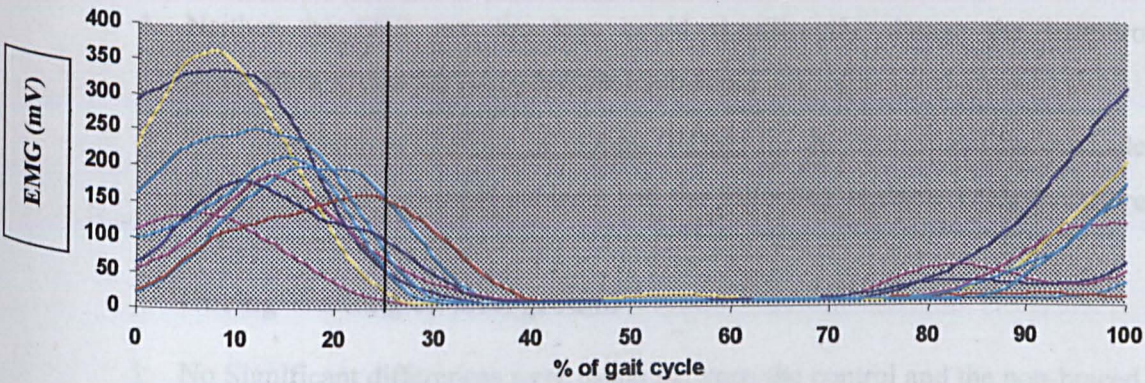

Figure 5-22 "Peak" and "Onset Activation Time" of the Gastrocnemius Muscles in Some ACL-Deficient and Control Subjects during Running on the Treadmill.

Control subjects Gastrocnemius - running on the treadmill



Non-braced ACL-deficient subjects Gastrocnemius - running on the treadmill



Braced ACL-deficient subjects Gastrocnemius - running on the treadmill

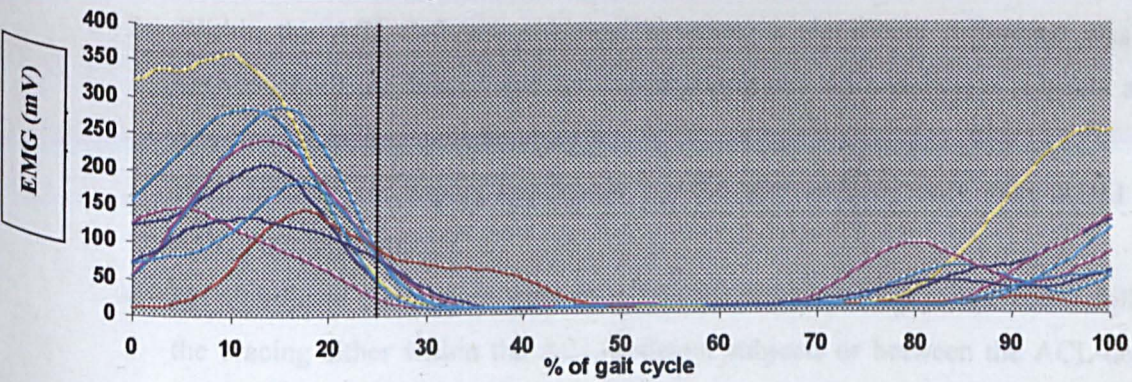

Taped ACL-deficient subjects Gastrocnemius - running on the treadmill

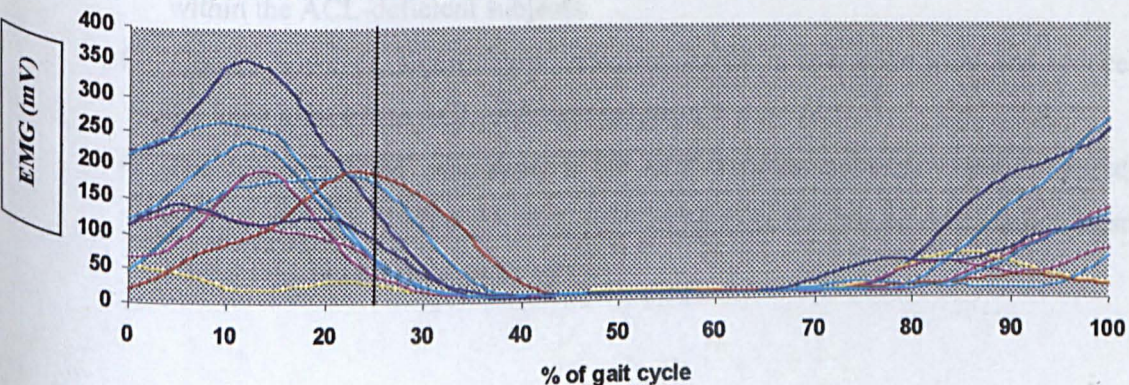

5.7. Summary of the Results

Gait analysis was carried out in 15 unilateral ACL-deficient subjects awaiting knee reconstruction surgery. Fifteen healthy subjects were selected for gait evaluation and were matched to the patient population by age, height, body weight and history of sport activities.

The Results Obtained in This Section Have Demonstrated the Following:

- ◆ The temporospatial gait parameters for the ACL-deficient subjects showed that these subjects walked level ground with the following characteristics:
 1. Significantly lower speed;
 2. Significantly shorter strides and fewer steps per minute;
 3. Significantly longer step and double support time.
 4. Neither the FKB nor the tape could significantly change the temporospatial parameters within the ACL-deficient subjects.
- ◆ The measurement of range of motion (ROM) for the control and the ACL-deficient groups showed that these subjects had the following characteristics in different test modes:

During Walking on level ground

1. No Significant differences were found between the control and the non-braced ACL-deficient subjects.
2. Within the ACL-deficient subjects, however, a significant difference was found between both the braced and the taped conditions ACL-deficient subjects and the non-braced ACL-deficient subjects.
3. Both bracing and taping conditions significantly reduced only knee ROM in the ACL-deficient subjects.
4. No significant differences were found on the ankle and hip joints' ROM following the bracing either within the ACL-deficient subjects or between the ACL-deficient and the control subjects. The braced ACL-deficient subjects showed the least ROM within the ACL-deficient subjects.
5. Taping, however, significantly increased ROM in the ankle joint and reduced it in the knee joint in the ACL-deficient subjects.
6. The "support ROM" was lower in the ACL-deficient subjects when compared to the control subjects. Within the ACL-deficient group, the braced ACL-deficient subjects showed the lowest support ROM.

During Walking on the Treadmill

1. Only ankle ROM significantly increased in the ACL-deficient subjects when compared to the control group. The Knee and hip joints showed no significant differences in terms of ROM relative to the control group.
2. Both bracing and taping conditions reduced knee ROM during walking on the treadmill although it reached to a significant level only following bracing.
3. FKBs significantly reduced both the ankle and the knee ROM and did not change the hip joint ROM. The braced knee ROM was much smaller than the control (healthy) subjects' knees.
4. Taping could significantly reduce only hip ROM during walking on the treadmill.
5. Contrary to walking on level ground, the "support ROM" was greater in the ACL-deficient subjects relative to the control subjects. The Braced ACL-deficient subjects showed the least ROM within the ACL-deficient subjects.

During Running on the Treadmill

1. No significant differences were found either between the ACL-deficient and the control groups or within the ACL-deficient groups with different supports.
2. Neither the brace nor the tape showed significant differences on the ankle, knee and hip joints.
3. Similar to walking on the treadmill, the "support ROM" during running on the treadmill was higher in the ACL-deficient subjects than that of the control group.

- ◆ The pattern of kinematic data showed that the ACL-deficient subjects walked and ran with the following characteristics in different test modes:

Walking on level ground

Knee Joint

1. Most knee kinematic parameters were greater in the ACL-deficient subjects than those of the control group.
2. Within the ACL-deficient subjects, bracing significantly reduced the maximum knee flexion angle in swing.
3. Taping, however, significantly increased the maximum knee flexion angle at heel strike and in the swing phase, and the mean knee angle in stance.

Ankle Joint

1. Since the ankle kinematic parameters in the ACL-deficient subjects were very similar to the control group, no significant differences were found between the ACL-deficient and the control group in terms of ankle kinematics.
2. Neither the FKB nor the tape could significantly change the kinematic parameters in the ankle joint.

Hip Joint

1. Except the maximum hip extension angle in the stance phase, the rest of the hip parameters increased in the ACL-deficient subjects relative to the control group, although the differences were not significant.
2. FKB did not significantly change the hip joint kinematics during walking on level ground.
3. Taping, however, significantly decreased the maximum hip extension angle in stance and the mean stance value when compared with the non-braced ACL-deficient subjects.

Walking on the Treadmill:

Knee Joint

1. In spite of existing higher kinematic values in the ACL-deficient subjects relative to the control group, no significant differences were found between them.
2. Both the FKBs and the tape conditions significantly increased the maximum knee flexion angle in swing, the mean stance and the mean swing values in the ACL-deficient subject.

Ankle Joint

1. The ACL-deficient subjects showed very similar kinematic parameters to those of the control subjects. No significant differences were found between them.
2. The FKBs significantly increased the peak plantar flexion angle and the mean swing values.
3. Taping significantly increased both the maximum ankle dorsiflexion, and ankle plantar flexion angles and the mean swing values in the ACL-deficient subjects.

Hip Joint

1. No significant differences were found between the ACL-deficient and the control group in terms of the kinematics in the hip joint.
2. The FKBs significantly increased the maximum hip flexion angle at foot strike and in swing phase.
3. Taping also significantly increased the maximum hip flexion angle at foot strike, the maximum hip flexion angle in swing and both the mean stance and swing values.

Running on the treadmill:

Knee Joint

1. The ACL-deficient subjects showed greater values in all parameters when compared to the control group although it did not reach a significant level in any of the parameters.
2. Neither bracing nor taping could significantly change any of the parameters in the knee joint during running on the treadmill.

Ankle Joint

1. Both ACL-deficient and control subjects showed very similar values in all parameters; so that no significant changes were found between them.
2. No significant changes were found within the ACL-deficient subjects following a FKB or taping.

Hip Joint

1. The ACL-deficient and control subjects showed very similar results in all parameters and no significant differences were found between them.
2. Neither a FKB nor taping could significantly change the kinematic parameters during running on the treadmill.

◆ Knee Rotation

Walking on level ground

1. No significant differences were found between the ACL-deficient and the control subjects in terms of knee rotation in walking on level ground.
2. Neither a FKB nor taping showed any significant differences in the stance or swing phases. However, the FKB significantly reduced total knee rotation in the ACL-deficient subjects when compared with the control group.

Walking on the Treadmill

1. The ACL-deficient subjects showed greater knee rotation angle both in stance and in swing phases when compared to the control group. The differences reached to a significant level in the stance phase and when the "total knee rotation" was compared between these two groups.
2. Only a FKB and not taping could reduce the total knee rotation during walking on the treadmill mainly in the stance phase. The reduction was significant when it was compared with the control group. No significant differences were found within the ACL-deficient subjects.

Running on the Treadmill

1. The maximum knee rotation in both stance and swing phases increased in the ACL-deficient subjects relative to the control group. However, it reached a significant level only in terms of total knee rotation ($P=0.016$). The greatest knee rotation occurred in the swing phase.
2. Both a FKB and taping significantly reduced the "total knee rotation" mainly in the stance phase.

◆ Knee Anterior-Posterior (A-P) Translation

Walking on level ground

1. The A-P displacement of the tibial virtual marker relative to the femoral virtual marker was significantly greater in all test modes in the ACL-deficient subjects when compared to the control group only in the swing phase (36.2%↑). No significant difference was found in stance phase.
2. A FKB significantly reduced the total A-P displacement in this level.
3. Taping, however, increased the A-P tibial translation in this level either in stance or in swing phases.

Walking on the Treadmill

1. Similar to walking on level ground, the ACL-deficient subjects showed significant differences in swing phase when compared to the control subjects (33.7%↑).
2. Bracing significantly reduced the A-P displacement in both stance and swing phases during walking on the treadmill.
3. Taping even increased the A-P displacement and showed a harmful effect.

Running on the Treadmill

1. The ACL-deficient subjects showed significantly greater A-P displacement than those of the control group (31.5%↑).
2. Bracing significantly reduced A-P displacement in the ACL-deficient subjects only in stance phase.
3. Taping, again, showed a harmful effect and increased the A-P displacement of the tibial virtual point relative to the femoral virtual point.

In summary, the A-P tibial displacement was significantly greater in the ACL-deficient subjects relative to the controls in all test modes. The FKB significantly reduced it in both stance and swing phases during level walking on the treadmill and in only stance phase during running on the treadmill. During walking on level ground, the total tibial translation was significantly reduced following only a FKB.

- ◆ The pattern of kinetic data showed that the ACL-deficient subjects walked level ground with different supports with the following characteristics:
 1. Although four out of fifteen ACL-deficient subjects showed a reduced quadriceps activity pattern in the ACL-deficient subjects (no quadriceps avoidance gait pattern was seen in this study), there was no significant difference between the normal and ACL-deficient subjects in terms of ankle, knee and hip moments.
 2. Neither bracing nor taping conditions could significantly reduce the moments of the knee joint. No significant differences were found between the normal and ACL-deficient subjects in terms of joint power.
 3. Except the maximum hip extension moment, none of the moment parameters showed a significant difference between ACL-deficient and control subjects. It was significantly lower in the ACL-deficient subjects relative to the control subjects.
 4. Bracing could significantly decrease the maximum hip flexion moment in the ACL-deficient subjects.
 5. In joint power, except the maximum ankle absorption, neither bracing nor taping could significantly change any power parameters in the lower limb joints.
 6. The maximum ankle absorption power significantly increased following taping only.
 7. The "support moment" and the "support power" were lower in the ACL-deficient subjects than those of the control subjects.

8. Bracing reduced both the "support moment" and the "support power" in the ACL-deficient subjects.
9. Taping, however, did not change the "support moment" but reduced the "support power".
10. The "support power" was absorptive in the ACL-deficient subjects, while it was generative in the control subjects indicating more eccentric muscle activities in the ACL-deficient patients and more concentric muscle activity in the healthy subjects.

◆ The three-dimensional force vectors were recorded in the normal and the ACL-deficient subjects during only walking on level ground and showed the following characteristics:

1. Except in the "impact impulse" value, no significant differences were found between the ACL-deficient and the control groups in any of the force parameters.
2. The ACL-deficient subjects showed significantly lower impact impulse forces when compared with the control subjects. However, it did not significantly change following either the FKB or the tape.
3. Both the brace and the tape significantly reduced the peak posterior (aft) shear force (X -) value in the non-braced patients when compared to the control subjects.
4. Taping was not effective in significantly changing any of the force variables.

◆ The activity of four muscles around the knee were monitored simultaneously using Telemetered EMG apparatus and showed the following characteristics:

1. No significant differences were found between the ACL-deficient and control subjects in terms of peak or RMS values.
2. Neither bracing nor taping could significantly change the peak or RMS in the walking on level ground.
3. Taping could significantly reduce the peak amplitude of the medial hamstring muscle during walking on the treadmill.
4. No significant differences were found during running on the treadmill in terms of peak or RMS values.
5. Compared to the control group, the ACL-deficient subjects showed significantly earlier onset activation time of the gastrocnemius muscle only in walking on level ground.
6. The FKBs could significantly reduce the onset activation time in the gastrocnemius muscle during walking on level ground and walking on the treadmill. However, it

could not significantly change the peak of the gastrocnemius muscle in any of walking or running trials.

7. Taping was not effective in changing either the onset activation time or the peak of the gastrocnemius muscle.
8. The non-braced ACL-deficient subjects showed no significant changes in either the onset activation time or the peak activity when walking on level ground was compared to walking on the treadmill.
9. The onset activation time in the non-braced ACL-deficient subjects was not significantly different among different movement surfaces. In other words, the non-braced ACL-deficient subjects had a reduced onset activation time either in walking on level ground or in walking on the treadmill. They did not show more reduced onset activation time during running on the treadmill versus walking on the treadmill.

CHAPTER SIX - DISCUSSION

Introduction

This Chapter presents some important issues about this study. Firstly, it contains a general discussion detailing the necessity of carrying out the study; the strengths and limitations of the study; and some confounding factors faced in the study will also be discussed. The main body of this Chapter is concerned with the interpretation of the results. A brief summary of the discussion can be found at the end of the Chapter.

6.1. GENERAL DISCUSSION

This study was conducted on ACL-deficient subjects who were on the waiting list for ACL reconstruction surgery. Although this indicates that the sample of patients in the study represents a substantial proportion of all types of ACL-deficient subjects, due to the inclusion and exclusion criteria, and the factors affecting knee stability before and after bracing/taping, all the ACL-deficient subjects should be considered individually and, therefore, the situation may differ from patient to patient.

In order to test and refine the experimental protocol in preparation for the main study, a minor study was organised. Two aims were to be achieved in this stage. Firstly, the intra and inter-days repeatability of the CODA *mpx30* system was to be checked to ensure the investigator that the results were consistent and in agreement with the general findings in the literature. Secondly, a small study on three ACL-deficient and three matched healthy subjects was carried out to provide the investigator with confidence that the study is applicable, and that the minor problems can be solved prior to the main study. For the main study the gait pattern of the ACL-deficient and the control subjects was analysed. The control subjects were matched for age, sex, height, body weight and training history. This allowed the data from the normal subjects to be compared with that of the ACL-deficient patients.

The number of patients who completed the study was sufficient in spite of the difficulty in recruiting ACL-deficient subjects who were willing to attend for the test free of charge.

With the inclusion and exclusion criteria, one patient who had a medial meniscus injury and had been misdiagnosed as an ACL-deficient patient was excluded from the test during the pilot study.

Great attention was taken in the data collection. During recording the investigator checked that the patients struck the force platform perfectly. All runs of data collection were checked immediately to ensure the investigator that the markers were fully in-view and the necessary information was correctly obtained.

6.1.1. Why Was This Study Necessary?

Having studied the recommendations mentioned at the end of the literature review (Chapter 2), the current prospective experimental case-control study was designed to determine the effects of a functional knee brace (FKB) or a type of taping on the tibio-femoral joint in athletes with an ACL-deficient knee.

An intensive review of the literature revealed that a gap of information still exists in the analysis of the knee joint's behaviour following ACL-deficiency, and the extent that a FKB or taping may affect the biomechanics of the ACL-deficient knee. Taping is quite new in this area and the studies are limited to some *in vitro* studies on the effects of taping on the cadaveric knee joint. *In vivo* assessment of the translatory kinematics of the tibia relative to the femur has been limited to the use of the current gait analysis tools and methods. However, a variable study including the angulatory kinematics of the affected knee, hip and ankle joints (the joints surrounding the injured knee), kinetic evaluation and EMG data during various forceful activities provided valuable information which enabled the researcher to understand better the effects of FKBs or taping on the ACL-deficient knees. In addition, with a new method of virtual marker application provided by CODA *mpx30*, an attempt was made to study the translatory movements of the tibia in the control and ACL-deficient subjects directly. A comparison of this data with the baseline data and those from the matched-normal subjects, showed the biomechanical issues of the injured knee in ACL-deficient patients before and after bracing / taping and determined the extent that a FKB or tape was /was not effective on the ACL-deficient knee.

Some of the most important issues regarding the necessity of carrying out extensive research in this field are:

- The majority of the studies carried out in this area are based upon tests during level walking on level ground, in which the forces applied on the injured knee are much less than those usually applied during real events, such as sports activities. The side-step

cutting manoeuvre has been mentioned as a forceful test situation in some studies (Branch 1989, Branch 1993, Andrews *et al.* IN: McLean *et al.* 1998). The problems regarding providing an equal test condition for all subjects including equal speeds and equal angle of foot landing, etc. in this manoeuvre have still not yet been solved.

- Some controversial issues still exist in ACL-deficient knees. For instance, the occurrences of the quadriceps avoidance gait phenomenon, the effects of bracing on the joints surrounding the knee joints and particularly the controversial role of gastrocnemius activity in ACL-deficient knees.
- Getting permission to use a home exercise tool, such as a treadmill for light to aggressive exercise, is a frequent question asked by some ACL-deficient subjects. Since treadmill exercise change the gait pattern (because of its moving surface), the results of the research in walking or running on the ground are not extendable to the treadmill. To date, with our best knowledge, there is no study on the effects of bracing or taping on the ACL-deficient knee during walking or running on the treadmill with advanced gait analysis systems.
- Taping is usually used for both small and large-injured joints in sports (in small joints more often than the larger ones). In spite of its frequent use there is a lack of information regarding the effects of taping on the tibio-femoral joint, even during walking on level ground. Furthermore, for athletes who want to take part in competitions using a brace is not allowed in most competitions (Hackney & Wallace, 1999). However, taping as a soft tool is not harmful to other players and is freely allowed in competitions, and frequently encouraged by coaches and instructors. Finding the positive effects of taping can be a major contribution to the ACL-injured athletes in enabling them to take part in competitions safely.
- Finally, studying the kinematics and kinetics, along with the EMG parameters in different levels of activity with different supports, will provide a better insight into the lower limb behaviour in normal and ACL-deficient knees, and is helpful in finding the real effects of bracing or taping on the knees with ACL-deficiency.

6.1.2. Strengths and Limitations of This Study

Introduction

Although all efforts were made to conduct a trial with as few confounding factors as possible, like many other investigations, this study has its own strengths and limitations. In this section, the strengths and the limitations of this study will be addressed.

6.1.2.1. Strengths

Carrying out a test on running level requires a motion analysis system with a high frequency (100 Hz and preferably 120 Hz). Most current optoelectronic devices use a 50-to-100 Hz frequency, which is suitable mostly for level walking tests. A survey of the literature shows that very few studies are available which provide running data, particularly running on the treadmill at high speed. Branch and Hunter (1990) studied ACL-deficient subjects during a side-step cutting manoeuvre. However, due to the low frequency motion analysis system used in their study (60 Hz), they failed to analyse the swing phase data and only analysed the stance data.

CODA *mpx30* gait analysis system provides a frequency range from 1-to-800 Hz (depending on the number of markers used in the study). In addition, the CODA *mpx30* system is supplied with very powerful and user-friendly software and a report-generator programme to use inverse dynamics automatically to obtain the kinetics from force and the anthropometric data. In the present study a 200 Hz frequency was used in kinematics, force and EMG data.

Following an extensive literature review the strength and restriction of the previous studies in this area were considered, and commented within the section of recommendation for future studies.

The Strength Points of This Study Compared with Previous Studies Are as Follows:

1. Firstly, this is a variable study providing a unique opportunity to study the kinematics, kinetic (including moments, joint power), force data, and EMG parameters on both normal and ACL-deficient subjects. There are very few studies covering all biomechanical requirements along with EMG findings, and the importance of

carrying out such studies has been frequently recommended (Vailas & Pink 1993; Beynon *et al*, 1996; Branch *et al*, 1993; Nemmeth *et al*, 1997).

2. Running a study on three levels, including walking on level ground, walking on the treadmill, and running on the treadmill, with three different supports in each level (with brace, without brace or tape, and with tape), will provide an ideal viewpoint of the effects of a FKB or taping on the ACL-deficient knee. It will also grant the opportunity to compare the pattern of walking on the treadmill with walking on level ground, and can be used as a reference for studies on the treadmill.
3. The study provides altogether the angulatory kinematics of the hip and ankle joint as well as the knee joint. This has frequently been emphasised in the literature (Siler *et al*, 1997; Wexler *et al*, 1998; Andriacchi, 1990; DeVita *et al*, 1992; Branch *et al*, 1993) to enable the researchers to determine any compensatory kinematic and kinetic effects of the hip and ankle joints following the restricted movements of the tested knee by a functional knee brace or taping.
4. To determine whether the quadriceps avoidance gait pattern, which is a debatable and controversial issue in some articles, occurs in the ACL-deficient subjects in this study. This is of particular merit for the researcher to challenge the idea issued and popularised by Berchuck (Berchuck *et al*, 1990), Andriacchi (Andriacchi, 1990) and Patel (Patel and Hurwitz, 1999).
5. To find the extent to which a DonJoy functional knee brace and the spiral method of taping (both used in this study) can help the ACL-deficient subjects to participate in sports confidently, and if possible to take part in competitions with taping instead of bracing, which is not allowed in most competitions (Hackney and Wallace, 1999).
6. The pattern of gait on the treadmill is completely different from that on level ground, and very few studies are available which evaluate the gait pattern on the treadmill. Studying the kinematics, and comparing the gait pattern on the same subjects along with the EMG findings, will provide unique data for researchers to determine whether the treadmill exercise is helpful or harmful for a specific injury.
7. Using healthy subjects rather than the apparently healthy knee of the ACL-deficient patients, as the control group. Some researchers have established that following an ACL injury in one knee some mechanical changes also occur in the non-injured knee, and have mentioned that the non-injured knee is not really a healthy knee. Therefore, it is supposed that for studies of the injuries on one knee, using the uninjured knee as the control group is not appropriate, and researchers are strongly recommended to use

the normal knees of healthy subjects as the control group (Vailas & Pink 1993; Berchuck *et al*, 1990).

8. Finally, the positive subjective effects of bracing have already been confirmed. However, the objective justification is not clear (Wojtys *et al*, 1987; Beck *et al*, 1986). Studying only the objective and not subjective finding is of merit in this study.

6.1.2.2. Limitations

The main shortcomings of this study are as follows:

1. In this study only the instantaneous effects of the bracing or taping on the tibiofemoral joint were studied. Some authors have mentioned the possibility of different biomechanical changes on the ACL-deficient knees following instantaneous wearing a FKB relative to long-term wearing of it (Tho *et al.*, 1997; Nemmeth *et al*, 1997). The original plan of the study was to test both the instantaneous and long-term effects of bracing/taping on the patients with an ACL-deficient knee. However, due to the problems faced in the returning of the braces to the investigator (by the patients), this part of the test was eliminated. This, of course, can be a limitation factor in the study, and carrying out a separate study in this area is highly recommended.
2. The positive effects of any orthotic agents in increasing the proprioception of the normal or ACL-deficient knee have frequently been pointed out in the literature (Jerosh *et al*, 1996; Jerosh *et al*, 1998; Perlaud *et al*, 1995; McNair *et al*, 1996; MacDonald *et al*, 1996). In this study, only the kinematic, kinetics and EMG effects of a FKB or taping were studied, and the proprioceptive effects of them were not investigated. It is somewhat possible that some biomechanical changes observed in this study may be due to the increased proprioception sense in the patients rather than the real effects of the brace or taping itself. Measurement of the proprioceptive sense during the studies on ACL-deficient subjects is also recommended.

The strengths of this study compared with similar studies previously conducted indicate that the study has a methodologically sound and an outstanding place within the literature. Examination of the weaknesses of this study shows that the weaknesses are not strong enough to play a major role or to affect the results. Compared with previous studies, the results of this study are less contaminated and more reliable.

6.1.3. Marker Placement Set-up

In this section, I want to explain more that the new marker placement set up, as used in this study, does not adversely affect the results. Surface marker movements (either movement between markers and the skin or between the skin and the underlying tissues) are a common concern in all gait studies and known as marker movement artefacts. Reinschmidt et al (1997) reported very good consistency in flexion/extension (sagittal plane) between skin and skeletal-based kinematics and not in other planes such as rotations, or knee abduction / adduction.

The marker placement used in this study is the standard set up of CODA, which was combined with a virtual marker facility option. This was set up by Woledge⁹ and approved by Charnwood Dynamics. To eliminate the single marker measurement error, an increased number of markers were used in this study as well as they were supposed to reduce the surface marker wobbling effects. In each marker cluster, a resultant virtual marker was defined to play an exact role as the real markers. To obtain increased reliability, the trends of both the virtual and the real markers were plotted and a complete consistency was found between them. Another concern in this study was the reliability of using surface markers during high-speed activities. The major threatening factor at this stage was the markers' wobbling during the trials, particularly during running on the treadmill.

A similar marker placement has been reported in the literature during running on the treadmill. McLean et al (1998) used a new method of marker placement which is very close to that used in the present study. They attached externally mounted retro-reflective markers securely to the limb under investigation with strapping tape. Markers were attached to a bony prominence where possible, and attachment sites were shaved to minimise marker movement during locomotion. The test situation was straight line running and side-step cutting.

In our study, the placement of markers on the lower limb was carefully chosen based on the advice of Cappozzo et al (1997) and Lucchetti et al (1998) to reduce marker movement artefacts. The graphs of kinematics and EMG findings in the trials on the treadmill demonstrate excellent consistency and high repeatability of gait cycles and the marker positions.

⁹ Personal communications, Sept. 1999, Professor Woledge, Roger, Director and Professor of Experimental Physiology, Human Performance Laboratory, RNOHT, Stanmore, London.

Since the marker placement was exactly the same in both the experimental and control groups, and the markers were not detached throughout the test (particularly during changing the orthoses), and all conditions were equal between the groups, it seems that the marker placement was not a detrimental factor in this study and did not affect the results. In addition, the researcher regularly checked the marker positions and drive boxes to ensure that they were in the correct places and fully in view.

Overall, the researcher believes that the aforementioned difficulties did not affect the results of the study or the overall findings.

DISCUSSIONS - RESULTS INTERPRETATION

6.2. Results Interpretation

The present study investigated the gait pattern of patients with ACL-deficient knees with different supports in different surfaces using a comprehensive three-dimensional motion analysis system with integrated force plate and Telemetered EMG.

For ease of presentation, I will first discuss the level ground and then the level treadmill findings. The kinematic issues including temporospatial parameters, ROM, joint position, knee rotation and A-P tibial displacement will be addressed and then I will cover the kinetic, force and EMG findings. A summary of all will be outlined at the end of this Chapter.

Knee joint movements are complex and occur in three planes during the gait cycle. Knee flexion and extension involve gliding, rolling and rotation between the femoral and tibial condyles (Crenshaw, 1987) which provides efficient transmission of power from the hip to the ankle in a variety of ambulatory modes.

The hypotheses to be tested in the current study is that functional knee bracing or specific spiral taping for ACL-deficient subjects would result in an improvement in the kinematics, kinetics (moments and joint power), and EMG parameters and that this improvement would be reflected in better functional ambulation.

The number of subjects recruited in this study was larger than the required numbers based upon the power calculation and was larger than the cases in a number of other published studies in this field (DeVita *et al*, 1992; Petrone and Rood, 1992; Beynnon *et al*, 1992; Eberle, 1992). The inclusion and exclusion criteria for patient selection restricted the participation of many patients in this study, and difficulties were encountered in finding patients matching the specific criteria of selection.

6.2.1. Kinematics

All the lower limb joint kinematics including the ankle, knee and hip joints have been investigated in this study. DeVita *et al* (1998; 1997; 1992), Wexler *et al* (1998), and Osternig and Robertson (1993) have also emphasised the preference of analysing all lower extremity joints in ACL-deficient subjects instead of studying only the knee joint.

Novacheck, (1995) used the terms “temporal and stride parameters” instead of “Temporospatial parameters”. The stride parameters, such as speed, stride length, and stride frequency are very important in gait analysis. Dean (IN: Shiavi, 1985), Grieve (IN: Shiavi, 1985), and Milner and Quanbury (IN: Shiavi, 1985), including others, have contributed to our knowledge of these essential parameters. The unanimous conclusion is that humans are capable of an eightfold variation in walking speed by varying both stride frequency and length. The speed of progression is made faster by increases in both parameters. As walking speeds fasten, a maximum limit on stride length is eventually reached after which the fastest speeds are only achievable by increasing stride frequency. As Drillis (IN: Shiavi, 1985) remarked: “a laboratory setting can induce shorter step lengths, thus causing slower speeds”.

The findings of this study confirmed that our patients with ACL-deficient knees walked with significantly different temporospatial gait parameters from the control subjects and were found to have a smaller number of strides, shorter stride length, a longer step time, a larger percent for the stance time and consequently a longer double support time. Although the bracing or taping resulted in an increase in the stride length and brought it closer to that of normal subjects, the reduced average stride length in the non-braced patients seemed to be correlated with a significant reduction in their walking speed. Gauffin et al (1997) reported similar velocities, stride length, and duration of support phases, postural control and similar sway during walking on level ground in ACL-deficient subjects.

With regard to Shiavi’s definition (1985), of normal values of self-selected speeds in the laboratory for slow, free, and fast walking speeds (which were 0.68, 0.98, and 1.39 m/sec, respectively), our subjects walked fast. The lower or higher temporospatial parameter is not an important issue itself and must be studied along with other findings.

There are controversial findings in the literature regarding the effects of bracing on the range of motion (ROM) of ACL-deficient knees (Knutzen *et al*, 1987; Knutzen *et al*, 1983; Carlsoo & Nordstrand IN: Branch *et al*, 1989 ; DeVita 1992; DeVita 1997). Knutzen (1987; 1983) reported a restricted ROM in ACL-deficient knees during running on the level ground. Zetterlund et al (1986) showed similar stride lengths during running on the treadmill in healthy subjects.

To the best of our knowledge, this is the first time that the complete results of the total ROM and support ROM in the ankle, knee and hip joints in ACL-deficient subjects

during level ground and level treadmill trials have been reported. The study of ROM in the knee, ankle and hip joints as the consequences of ACL-deficiency or bracing is important. Restriction of a joint movement may produce some compensatory motions either in that joint or in the joints above or below the restricted joint. For example, a FKB may restrict knee full extension but it may increase knee rotations or change the hip or ankle ROM to compensate for the restricted knee and therefore, result in greater forces on the ankle or hip joints.

In the current study, changes in ROM were measured in the ankle, knee or hip joints in gait modes tested. During walking on level ground, the ACL-deficient subjects showed lower ankle and knee ROM compared with the control subjects the value for ROM were reduced even more following bracing. This finding is in agreement with Carlsoo and Nordstrand (IN: Branch *et. al*, 1989) and Knutzen (1987; 1983). By contrast, during walking on the treadmill, the ACL-deficient subjects showed more ankle ROM than that of the control subjects. Bracing could significantly reduce the knee ROM during walking on level ground and walking on the treadmill. Taping, however, reduced only the knee ROM during walking on level ground, but not while walking on the treadmill. Bracing had the greatest effect on the knee joint. However, taping was more effective on reducing ankle ROM during walking on level ground and walking on the treadmill. While running on the treadmill, neither the FKB nor tape showed any restrictive effects on the ankle, knee or hip joints. In other words, neither bracing nor taping could limit the ROM of the lower limb joints during high-speed running on the treadmill. This is in agreement with Eberle, (1992) who reported no significant differences in the ROM of seven ACL-deficient subjects during level ground straight running when compared with control subjects before and after bracing.

I found "support ROM" to be a valuable measurement which gives the investigator an overall idea of the effects of ACL-deficiency and/or orthoses on the lower limb joints as a whole. I found that a smaller ROM was required in the lower limb joints during level treadmill trials when compared with walking on level ground. This was especially pronounced during running on the treadmill, which required even less support ROM in the control subjects relative to the ACL-deficient subjects. However, this does contradict Novacheck's studies (1995; 1998) in which he reported a significantly greater ROM during running on level ground. He reported that nearly 90 degrees ROM was required for the knee joint during level ground running and emphasised that this knee

ROM may reach 130 degrees during sprinting in professional athletes. I believe the reasons that a greater ROM is needed for level ground trials relative to treadmill trials might be due to the bouncing effects of running on the treadmill. During level ground walking trials, the impact ground reaction force is 0.8–1.5 times body weight (Perry 1992). This reaches 3–5 times body weight during running trials (the higher the speed, the more the impact GRF). While during running on the treadmill, the impact GRF is greater than that of level ground running, the bouncing effects of this higher GRF made the subjects jump higher during running and thus no more knee flexion was needed for toe-clearance.

Our subjects held the treadmill's front bar during running on the treadmill. This was used to provide more security and confidence to the subjects, particularly the ACL-deficient patients, to help them run normally and encourage them to use the lower limb normally as possible. They were also encouraged not to lean forwardly and to run as straight as they could. Siler (1997) has reported no significant kinematic changes in his subjects during running on the treadmill with and without holding on to the stands. The results showed that subjects with a limited ROM can run on the treadmill even though they may not be able to run over the ground. A better look at the lower limb ROM showed that the control subjects had smaller "support ROM" during walking on the treadmill than recorded while walking on level ground. The greatest changes occurred in the hip joint ROM when walking on level ground was compared with walking on the treadmill. The hip joint ROM significantly decreased when walking on the treadmill while the ankle and knee joints ROM remained constant. However, during level running on the treadmill, while the hip ROM was approximately similar to that recorded when walking on the treadmill, the ankle ROM significantly increased. Therefore, the greatest hip ROM occurred while walking on level ground, while the ankle joint showed the greatest ROM during running on the treadmill.

Regarding the kinematic findings in this study, the kinematics of the lower limb joints in the control subjects were similar in shape and magnitude to those reported in the literature (Perry, 1992). In this study, the biomechanical evaluations have been differentiated into changes between the normal and the ACL-deficient knees and I studied the changes before and after bracing or taping, with the emphasis applied to the alterations following bracing or taping. The biomechanical data and graphs for this study on normal subjects were very consistent with the normal data reported in the literature, mostly with those

have been recorded by surface markers (Perry, 1992; DeVita *et al* 1992 & 1997; McClay *et al* 2000; Hamil *et al* 1992).

The ankle, knee and hip joint angles for each stride evaluated were normalised over the percentage time of the gait cycle and averaged across all subjects. The mean normalised curves for each joint were then plotted against time to investigate the possibility that the discrete nature of the parameters analysed statistically obscured differences in joint motion appearing over the course of the stride cycle.

6.2.1. 1. Level Ground

Walking on level ground is the most common gait studied and can be classified as slow, medium and fast walking; running; sprinting; jogging, etc.

Flexion/Extension movements are the largest component of total knee motion during walking. Reinschmidt *et al* (1997) in their studies reported little difference between skin and skeletal-based kinematics as the flexion/extension patterns were in general agreement across subjects.

Large kinematic differences were found in the ACL-deficient subjects versus normal subjects in our study. Berchuck *et al* (1990) have pointed out that even in patients who have asymptomatic ACL-deficiency, the mechanics of the knee joint are greatly altered by adaptive changes to the patterns of gait.

In this study, the non-braced ACL-deficient subjects showed a turn towards higher ranges of knee flexion angle throughout the gait cycle including midstance although this was not significant. This is in agreement with the findings of Kadaba *et al* (IN: Roberts *et al*, 1999) and Andriacchi *et al* (1990) who reported an increased range of knee flexion in ACL-deficient subjects during midstance. The results also confirmed Beard's study (1996) who found a larger knee flexion at heel strike and at midstance in ACL-deficient subjects. Adding a FKB decreased knee flexion and caused the braced ACL-deficient subjects to walk with a less flexed knee than that of the non-braced patients but was still more than that of the control subjects. The findings reinforced Knutzen's study (1987) which had already shown a reduced maximum knee flexion angle in braced ACL-deficient subjects in both stance and swing during level ground straight running (Knutzen *et al*, 1983). However, they emphasised that the difference was significant only in swing phase.

Although Branch et al (1993) reported no changes following bracing in ACL-deficient subjects in their study, this may be due to the fact that their study was incomplete as a result of the use of an old motion analysis system with low capability. They stated that because of many difficulties related to the passive reflective markers and the low frequency (60 HZ) cameras, they were not able to track many runs. Furthermore, due to un-shuttered 60 HZ cameras that led to trails on the tracking images, the swing phase was not analysed (the phase in which the most changes occurred in our study) and they could only analyse the stance phase of the manoeuvre.

In the current study, most changes occurred in the braced ACL-deficient subjects during swing phase while walking on level ground. The brace could significantly reduce the maximum knee flexion in swing phase and made the ACL-deficient subjects walk with more erect posture relative to the non-braced patients but still more flexed than the controls. Taping, however, did not act as a restraint to knee flexion. The erect posture walking mentioned by DeVita et al (1992) in ACL-reconstructed patients was not confirmed in our study and conversely our patients were found to have a more flexed knee relative to the control subjects. This might have been due to the fact that DeVita's patients had undergone ACL-reconstruction surgery and were expected to walk in the pattern of a healthy subject. In Knutzen's study (1983) a type of elastic knee support was used which increased knee flexion that was shown in this study as increased "mean stance" and "mean swing" angles following the taping. This was found in our study in the taped ACL-deficient patients.

Beard et al (1996) concluded that the larger knee flexion range during midstance in ACL-deficient subjects could be a compensatory effect to place the hamstring in a better position to control the tibia from forward transition. In our study, when the ACL-deficient subjects wore a FKB, they had a reduced knee flexion range and did not use their physiological compensatory protective system. This was likely to be because the patients trusted the braces as a protective agent for their knees, however, while, by contrast, they did not trust the taping and retained the knee in the more flexed position. The mean stance and swing values in the ACL-deficient and in the control subjects confirmed that the control subjects walked with a less flexed knee in both stance and swing phases when compared with the ACL-deficient subjects. Wearing a FKB reduced knee flexion angle range in both stance and swing phases, although this was significant

only in the swing phase. Taping, however, increased knee flexion in the whole stance and swing phases and did not show any restraint effect.

The lack of a plantarflexed or neutral ankle position at heel strike in the ACL-deficient subjects, was found in the present study, this resulted in the lack of dorsiflexion moments at heel strike stage.

The increased hip flexion in the ACL-deficient subjects might be a consequence of compensation for weak quadriceps muscles. This has already been reported by some investigators (Berchuck *et al*, 1990; Patel *et al*, 1999). With a FKB, the patients' hip flexion at heel strike was reduced but non-significantly, and approached the values for normal angle. The braced knee patient was also noted to have more hip extension relative to the non-braced ACL-deficient subjects. With taping, however, the patients did not reduce their hip flexion and continued with a more flexed hip position and even increased their hip flexion in stance. This indicates that taping had no compensatory effects on the hip kinematics probably because the taped patients did not feel confident enough to walk in an upright position as they did when a FKB was used.

In conclusion, during walking on level ground, the ACL-deficient subjects showed a more flexed knee at heel strike and throughout the stance phase and a more flexed hip at the heel strike. The braced ACL-deficient subjects showed less knee flexion in both stance and swing phases (but still more flexed than the controls), and had a less flexed hip than the non-braced ACL-deficient subject and had more plantar flexion. In the taped ACL-deficient subjects, all knee kinematic variables increased and the taped patients walked with an even more flexed position which might be a consequence of their greater need for knee protection. No significant changes occurred in the ankle or hip joint angles in the taped ACL-deficient subjects.

6.2.1. 2. Level Treadmill

Nigg and Cole (1999) questioned if the recorded biomechanical parameters on the treadmill were similar to those for level ground gait. They tested 22 healthy subjects during running on four different surfaces: level ground plus three treadmills that differed in size and power. They found that the kinematics of the subjects was different when comparing level ground and level treadmill running. They divided the differences into systematic and subject dependent components and concluded that using individual

assessment of running kinematics on a treadmill may possibly lead to inadequate conclusions about level ground running.

As mentioned earlier, since the number of studies carried out on the treadmill is very few in ACL-deficient subjects and there is no study focusing on bracing in ACL-deficient subjects during treadmill exercise, the results in this section cannot be compared to the other researcher's findings.

The research studies of ACL-deficient subjects on the treadmill are very limited. Their studies have focused more on EMG studies rather than kinematics. This is likely due to lack of advanced motion analysis systems for recording movements during treadmill exercise (particularly fast movements). The subjects in this study grasped the front bar of the treadmill only during running and not while walking on the treadmill.

6.2.1. 2.1. Walking on the Treadmill

In agreement with Novacheck (1995), Osternig and Robertson (1993), and Lange (1996), the general pattern of the tibio-femoral joint positions during walking on the treadmill did not show fundamental differences from those of walking on level ground. Clear differences occurred during walking on level ground and walking on the treadmill in the current study. In both conditions, only the ACL-deficient subjects started with a greater knee flexion. This seems to be due to their adaptation to the injury and might be a compensatory change for their abnormal biomechanics. This greater knee flexion altered the hamstring muscles to a better position to pull the tibia back and therefore reduced the A-P tibial translation. During walking on level ground, the braced subjects achieved sufficient confidence to return to a relatively upright position. They walked with a smaller knee flexion angle and brought their knee position close to the control group.

However, while walking on the treadmill, neither the braced nor the taped patients returned to the upright position and both groups walked with a flexed knee. This probably reflects a lack of confidence in the patients in this trial. The taping group while walking on the treadmill, as opposed to walking on level ground, showed the same results as the bracing group. The taped ACL-deficient subjects had a greater more knee flexion angle than both the control group and the non-braced ACL-deficient subjects during walking either on level ground or on the treadmill. There are two possible explanations for this. Firstly, it might have been that taping provided as little restriction as bracing for the ACL-deficient knees during treadmill trials. The second possibility is that, since walking on the

treadmill seems to be more difficult relative to walking on level ground, they did not trust their ACL-deficient knee even when braced or taped to allow them to walk in an upright position as they did while walking on level ground.

A comparison of the pattern of ankle motion during walking on the treadmill and walking on level ground shows that the general pattern of movement was very similar. However, there was a lack of ankle plantar flexion after heel strike and a shortening of the stance phase period while walking on the treadmill.

In the present study, there was no significant difference between normal and ACL-deficient subjects in any phases except in the range of the ankle plantar flexion while walking on the treadmill. When a FKB was worn, it did not show any effects in stance. However, on the swing phase, it significantly increased the ankle plantarflexion angle. The taping was also effective in changing the ranges of both dorsiflexion and plantarflexion and significantly increased both values. It seems that because of the limitation of knee ROM by a FKB or by taping, the subjects compensated for this by increased ankle movement in an open kinematic chain, which is plantarflexion. Increased plantarflexion reflects an increase in gastrocnemius activity as confirmed by EMG recordings shown in this study and this will be discussed later.

The sagittal plane hip motion is essentially sinusoidal in walking on level ground and treadmill. The maximum hip extension occurs just before toe-off and maximum flexion occurs in the terminal swing phase (Novacheck, 1998). In this study, the control and non-braced ACL-deficient subjects hit the treadmill with much less hip extension than that of the braced or taped ACL-deficient subjects, although this difference was not significant. The hip ROM was very similar in the non-braced ACL-deficient and in the control subjects and no significant differences were found between them. Wearing a FKB or taping significantly increased the hip flexion angle at heel strike and during the swing phase. This might be a compensatory phenomenon for lower knee extensor moments following knee bracing which also occurred in walking on level ground (Patel *et al*, 1999). Indeed, the braced or taped ACL-deficient subjects compensated for the restricted knee ROM with a more hip flexed position (forward lean) during walking on the treadmill and walking on level ground.

While walking on the treadmill, the total hip ROM in the ACL-deficient patients was significantly less than that recorded while walking on level ground in the control group.

Interestingly, although the stance phase period was nearly 15% shorter in level treadmill walking than that of level ground, the maximum extension angle occurred just before toe-off in both situations as is usual in other level ground studies. This means that while walking on the treadmill, all phases occurred earlier than those for the level ground tests. While running on the treadmill, all phases of the gait cycle occurred even sooner than from those of walking on level ground or walking on the treadmill.

In conclusion, while walking on the treadmill, increased knee kinematic variables occurred in the non-braced ACL-deficient patients and they walked with a more flexed knee. No significant differences occurred in the ankle or hip joint kinematics in this group. When wearing a FKB, they showed an even greater knee flexion angle (opposite to that of walking on level ground). They had more hip flexion at heel strike and swing phase and a greater ankle plantar flexion angle at both heel strike and during the swing phase. This highlights that the patients adapted to walking on the treadmill with a greater physiological adaptation (more knee flexion) than would be expected if they trusted in the brace or tape. Taping also increased more ankle, knee and hip flexion angles indicating that the subjects did not trust either taping or bracing while walking on the treadmill.

6.2.1. 2.2. Running on the Treadmill

Studies of running were fuelled by the explosion of interest in running as a recreational activity in the 1970s (McClay & Manal, 1999). This highlighted interest, and with improved technological and computational abilities at that time, generated a multitude of studies of the mechanics of running. These studies were critical to the development of an understanding of the forces and movements involved in running and served as the foundation for all later investigations. Another major impetus of running research, however, was the increase in running-related injuries reported by physicians. The descriptive studies of the 1970s and 1980s were unable to provide information regarding causal relationships between running mechanics and injury. Studies of injury mechanisms were largely anecdotal and provided little insight into aetiologies and preventive measures.

In the present study, since the treadmill speed was relatively high (10 Km/hr), the subjects were allowed to grasp the handrails, but the subjects were encouraged not to run in a forward leaning position and were asked to keep themselves upright. Siler (1997) carried out a test to define whether or not grasping of handrails during treadmill walking affected

the sagittal plane kinematics. The results showed that grasping of handrails did not significantly alter changes in the sagittal plane kinematics of the knee. They concluded that subjects might be allowed to grasp the treadmill handrails without affecting sagittal plane kinematic. The other important point in our study is that since both normal and ACL-deficient subjects grasped the handrails during running on the treadmill, this did not act as a confounding factor in our results.

The pattern of the tibio-femoral movements during running on the treadmill was fundamentally similar to those of walking on either level ground or on the treadmill. However, the knee angles in all phases of the gait cycle were higher than those identified during the walking trials. The overall picture of the gait pattern was close to that found during walking on the treadmill except that all phases occurred slightly earlier while running on the treadmill and stance phase period was very short (25% of the gait cycle). The values found in our study are completely different from McClay's study (IN Ramsey *et al*, 1999) who reported the kinematic values during running level ground. They found that the knee generally flexed 10-20 degrees at heel strike to around 30-40 degrees approximately 40% during stance phase. The knee then extended shortly before toe-off and flexed in preparation for the swing phase. It seems that the main difference between the values of McClay's study (2000) and the present study is the different running surfaces and probably the speed of running (the speed of running was not reported in their study). Their subjects ran on level ground and our subjects ran on the treadmill.

The present study showed that the pattern of gait during walking on the treadmill was close to that of walking on level ground. However, the pattern of gait while running on the treadmill was very different from that reported by others for running on the ground. Novacheck (1995) found a 39% of stance phase during running on the ground in children ages 5-18 years old in a 3.21 m/sec speed (25% greater than that of our subjects which might have been due to the age of the subjects, the speed of running and the surface they were running).

The patients in our study had a mean maximum knee flexion of 53° which was higher than the 44° reported by Hamill (1992) while running on the treadmill and much lower than 90 degrees that Novacheck reported for running on the ground in professional runners. Since we know maximum knee flexion is directly correlated with the speed of running, it is unfortunate that Hamill (1992) did not mention speed in their study. It is,

therefore, not possible to compare the different knee flexion angles between the two studies.

In the present study, the non-braced ACL-deficient subjects ran with a generally more flexed position when compared to the control subjects. This was mainly noted from the initial contact point of gait cycle when they struck the treadmill with a more flexed knee which might have been a compensatory change to allow to activate the gastrocnemius earlier thus increasing knee stability by contracting all four muscles around the knee joint. Neither bracing nor taping resulted in any significant changes in the ACL-deficient subjects while running on the treadmill.

Snyder-Mackler (IN: Roberts *et al*, 1999) divided the ACL-deficient subjects into "copers" and "non-copers" subjects. The "coper" subjects were those who could maintain high activity levels, experiencing neither instability, loss of function or weakness despite complete rupture of the ACL (Eastlack *et al*, 1999; Murray *et al*, 1964; Dale *et al*, 1994). In this group, the knee did not give way, even under stressful conditions like jumping and pivoting. These individuals were able to return to all pre-injury activities without reconstructive surgery and often without the use of a brace (Eastlack *et al*, 1999). The "non-copers" showed gait abnormalities such as locking, giving way, etc. and were not able to return to their previous level of activities. Steele and Brown (1999) reported a Lysholm score of <84 indicating that despite the ACL-deficient subjects being able to perform deceleration tasks, these functional ACL-deficient subjects still experienced knee instability symptoms during daily activities.

We investigated our subjects' knee instability by quantifying their Lysholm scores (Lysholm Score, Tegner & Lysholm, 1985). In our study, only three (20%) scored above 84 and in twelve (80%) scored less than 84. All three patients (with scores >84) had experienced giving way rarely. Although the mean Lysholm score in our study was 67.4 ± 18.4 , according to the Snyder-Mackler (IN: Roberts *et al*, 1999) and Steele and Brown (1999) classifications, our subject group would generally be considered to be "non-copers" ACL-deficient subject with the history of occasionally giving way, they showed good control on tibial displacement during high load activity. No significant differences were identified in the A-P displacement for the ACL-deficient patients in the stance phase.

Andriacchi et al (1997) reported that during stressful activities, the ACL-deficient subjects demonstrated a functional adaptation associated with an increased knee moment produced by the hamstrings during the early phase of these activities. This type of adaptation suggests that patients with ACL-deficient knees may use more hamstring activity to provide muscular substitution for the absent ACL during more stressful activities. Since the moments were not calculated during treadmill trials in the present study, Andriacchi's concept could not be directly investigated. However, as all of our patients had an increase in ankle, knee and hip flexion angles in treadmill trials at heel strike, this might have been directly due to increased knee flexion moments as Andriacchi reported. Our EMG data showed an increased muscle activity in all of the four muscles around the deficient knee only during running on the treadmill. Bracing, however, reduced the hamstring activity, which might indicate less need of muscle activity when a FKB is used in the ACL-deficient knees.

During running on the treadmill, there were large differences in the ankle angles between walking on level ground, walking on the treadmill and running on the treadmill in our study, which contrasts with Novacheck (1998) who stated similar ankle angle for level ground walking and running trials. The treadmill runners (both the ACL-deficient and controls) did not show any initial ankle plantarflexion in loading response.

In an overview of the ankle joint position in different trials, one can infer that the initial and last parts of the ankle joint curve was gradually omitted in walking on the treadmill; and only the middle part of the curve remained while running on the treadmill (Figures 5-5 to 5-7). In other words, during running on the treadmill, the ankle joint angle curve is an enlargement of the curve seen between the 20% and the 90% points of the gait cycle as seen when walking on level ground. The first 20% and the last 10% of the cycle were gradually omitted during walking and running on the treadmill highlighting that the patients started the gait with a more ankle plantar flexion angle.

The ACL-deficient subjects started running with a more flexed hip position. Adding a FKB or taping had no effect on the hip positions. It seemed that during high speed running on the treadmill, the ACL-deficient subjects run in the same way as the control subjects and they were able to control their abnormal gait pattern. Although they started with a more flexed position, there were no significant differences between the ACL-deficient and the control subjects. In fact, no compensatory kinematic changes occurred in the ankle or hip joint of the ACL-deficient subjects. The results of these tests, particularly

running on the treadmill would be different if the running test was carried out over level ground.

In summary, the overall tibiofemoral gait pattern was approximately similar in shape at all test levels. However, the main differences, which were noted were the values and the percentage of time for the stance and swing phases at the different test levels of activity. The greatest stance time was recorded during walking on level ground (~65%). Walking on the treadmill had the second largest stance time (~55%) and running on the treadmill showed the least stance time (25%) and consequently the greatest swing time period. This means that percentage stance time is directly related to the speed of activity. Although the subjects walked on the treadmill with a slightly slower speed when walking on level ground (1 m/sec vs. 1.3 m/sec), their stance phase period was shorter than that on level ground. This could be explained by the different characteristics between moving on the treadmill and moving over the ground due to the non-stationary surface of the treadmill.

The ACL-deficient subjects showed a more flexed knee, hip and plantarflexed ankle at heel strike at all levels of activity, which seems to be part of their compensatory gait patterns associated with their ACL-deficiency. This seems to occur subconsciously when carrying out level ground and particularly level treadmill walking.

When the patients wore a functional knee brace, different changes occurred at different levels of activity. When walking on level ground, they moved to an upright position and their knee angle came very close to the control subjects' knee position after heel strike. However, during walking on the treadmill, they did not return to a normal level and even continued with a more flexed knee, which might be partly due to the moving surface of the treadmill. During running on the treadmill, although a non-significant increased knee flexion was shown in the ACL-deficient subjects, the brace did not significantly change knee angles. In fact, there appeared to be no need for a brace during running on the treadmill so that the brace efficacy was not tested in this situation.

In contrast to bracing, taping did not play a significant role during walking on level ground to bring the knee angle to its more normal position. The taped subjects walked with a more flexed knee position when compared with their untreated condition. In fact, it appeared that they did not trust the taping, as they did not returned to walk in an upright position during walking. Neither bracing nor taping could return the deficient knee position to its normal level during walking on the treadmill. This could be explained by

compensatory changes occurring to put the tibia in a better position to increase gastrocnemius activity, which will be explained later. During running on the treadmill, the ACL-deficient subjects adapted well enough to run without problems simply by increasing their knee flexion and recruiting all muscles around the knee to stabilise the knee joint (Markolf *et al*, 1978).

It is clear from the present study that the greatest kinematic changes occurred while walking in both situations but not while running which is in agreement with Berchuck's finding (1990).

The above results support some part of our hypothesis that giving a FKB would result in an advantage to the ACL-deficient knee only in low force activities and that a FKB would bring knee kinematics closer to the healthy (or safer) condition better than taping. However, with the above findings, we cannot confirm the part of our hypothesis regarding the usefulness of taping in the ACL-deficient knees during different levels of activity. In the running trials, the efficacy of bracing or taping was not tested due to the fact that the patients adapted very well to the forceful running condition by increasing the flexion angle and the activities of the muscles around the knee joint.

6.2.1. 3. Knee Rotation

In the normal knee, passive knee flexion to about 30 degrees is usually coupled to internal rotation, which decreases if the ACL is absent (Lafortune *et al*, 1992). Pushing the flexed tibia backwards may cause a further reduction of this internal rotation or even result in external rotation when the ACL is absent (Jonsson *et al*, 1989). When the lateral tibia is displaced anteriorly, as during the pivot shift test, the internal rotatory laxity increases (Karrholm *et al* IN: Jonsson *et al*, 1989; Noyes *et al* IN: Jonsson, 1989).

There is a link between excessive knee axial rotation and ACL injury with the ligament being at risk of injury from both excessive external and internal tibial rotations. Maximum internal tibial rotation can increase the risk of ACL injury by causing the ligament to lever against the posterior cruciate ligament and the inter-condylar notch. Conversely, maximum external tibial rotation will compromise the integrity of the ACL as the ligament acts to restrain this movement by impinging against the lateral femoral condyle.

Internal rotation of the knee accompanied by the applied anterior translational force results in a force couple. Nordt *et al* (1999) found that the total internal rotation in the

healthy knee during walking was 10.8° and the external rotation was 7.4° . Perry (Perry 1992) reported the total rotation was 9° . Laforune et al (1992) used intra-cortical pins and found the external rotation was 6° and the internal rotation was 7° in an *in vivo* study on normal subjects. The investigator is not aware of any *in vivo* test on the ACL-deficient knee using an advanced gait analysis system to identify knee rotation.

In the current study, the values for knee rotation were relatively consistent during the tests particularly during treadmill tests. While walking on level ground, the graphs were consistent when no brace or tape was used. Bracing or taping always dramatically altered the values for rotation, which might have been the effect of restriction of knee movements. While walking on the treadmill, since more than one gait cycle was provided in each trial, the consistency could be checked more easily. Generally, during treadmill trials the data collected approached reproducible and the results could be better trusted (see Figure 5-3). In our study, generally, the external rotation occurred during the stance phase and the internal rotation occurred during the swing phase. The peak internal and external rotation and the total knee rotation were all measured in this study. The maximum internal rotation was larger than the maximum external rotation in both groups. In the present study, the peak internal and peak external rotation of the knee was obtained during different tests and with different supports and then compared with the control group. The first part of internal rotation which occurs during 0-10% of the gait cycle (weight acceptance period), which has reported by Lafortune et al (1992), did not occur either in the ACL-deficient or in the control subjects in our study.

To synchronise and make the rotation values comparable in different subjects, all data was normalised to the heel strike point as the zero value. Therefore, the values mentioned in this study may not necessarily be similar to the absolute values mentioned in the literature. However, this helps to define the temporal effects of a FKB or taping on knee rotation.

The present study provided a perspective on the so-called "screw home" mechanism of the tibiofemoral joint which has been discussed in many clinical textbooks (Ficat & Hungerford, 1977; Frankel & Nordin, 1980; Williams & Warwick, 1980). The various authors described the "screw home" mechanism as the medial rotation of the femur with respect to the tibia or lateral rotation of the tibia with respect to the femur, associated with

the later stages of extension of the knee (Williams and Warwick, 1980). This mechanism was clearly shown in this study. Lafortune et al (1992) contradicted this conventional view and stated that in their study the screw home mechanism occurred as external rotation of the femur relative to the tibia and questioned the accepted view that tibia rotates externally relative to the femur in the later stages of knee extension.

In our study, during walking on level ground, there was a non-significant difference in knee rotation in the stance and swing phases between the non-braced ACL-deficient and the control subjects. It seemed that the ACL-deficient subjects reasonably controlled their tibial rotation and there was no need for bracing or taping. This agrees with Jonsson et al (1989) who claimed that non-braced ACL-deficient subjects may have normal knee rotation.

During walking on the treadmill, the maximum external rotation occurred at a point 16% into the whole gait cycle during stance phase (much earlier than walking on level ground). Then, the tibia internally rotated and reached to the peak of -5° to -7.5° at a point 69% into the whole gait cycle. It then externally rotated and the Screw Home Mechanism was clearly demonstrated. It should be noted that the shape of the knee rotation angle was fairly similar when comparing walking on level ground and walking and running on the treadmill.

During walking on the treadmill, in spite of lower speed and less force applied to the subject's knee, the ACL-deficient subjects showed remarkably increased knee rotation, particularly internal rotation (which was significant in stance phase) and in total knee rotation. Bracing could significantly reduce knee rotation in both stance and swing phases and could bring the measurements close to those found in normal knees. Taping was also effective in controlling tibial rotation in the stance and swing phases during walking on the treadmill. The interesting point in this part of the study was that, similar to other angulatory kinematic results in walking on the treadmill, knee rotation also occurred earlier in walking on the treadmill. This might also reconfirm our hypotheses regarding the walking style changing during treadmill activity that might be due to the moving surface of the treadmill.

There is very little research, which describes the patterns of axial rotation of the knee during running at high speeds. This void is most likely due to the inability of measuring devices used in earlier research to accurately quantify complex angular movement

patterns in three dimensions (McLean *et al*, 1998). During running on the ground, McCaly and Manal (1999) found that from heel strike to midstance, the knee internally rotated, followed by an external rotation although slight differences in magnitudes were evident between the groups. In our subjects and during running on the treadmill, the tibia externally rotated and reached to a maximum of 1° of external rotation at about 22% of the whole gait cycle and then internally rotated during swing and reached a peak value at 60% of the gait cycle. Short stance phases were associated with the least external rotation.

During running, despite this being a forceful activity, rotation was less than that found during level walking on the treadmill but was more than that recorded for walking on level ground. This might be explained by the following mechanisms. During running on the treadmill, the subjects jumped vertically on the surface (bouncing effect) and due to the short stance period in high speed running, the leg was not free enough to rotate easily. In other words, since the normal heel strike – toe off pattern did not occur and the movement was more vertical than horizontal, the screw home movement did not take place properly. During walking on the treadmill, the stance period was longer and with the activation of the hamstring muscles, particularly the medial hamstring, the tibia internally rotated during midstance up to toe-off. The ACL-deficient subjects showed significantly more total knee rotation relative to the control group and a FKB significantly reduced total rotation bringing this value close to that found in the control subjects.

The ACL-deficient subjects showed larger amounts of knee rotation relative to the control subjects at all levels but the difference was not significant. This is in agreement to Czerniecki and Lippert (1988) who found no significant differences between the normal and the ACL-deficient subjects during walking on level ground. The largest tibial rotation (internal rotation) occurred during the swing phase. The FKB always reduced the excessive total knee rotation and showed a good effect but this reached a significant level only during walking on the treadmill. The FKB was more effective during the swing phase than the stance phase. Knutzen (1987; 1983) reported a good effect of bracing in reducing total tibial rotation in ACL-deficient subjects during walking on level ground.

Jonsson and Karholm (1990), however, reported a significant effect of bracing in reducing only external tibial rotation. In the present study during the stance phase, the largest tibial rotation occurred during walking on level ground. The next largest was seen during walking on the treadmill and the least tibial rotation while running on the treadmill. During swing phase, the largest tibial rotation was related to walking on the

treadmill, the next largest while running on the treadmill and the least when walking on level ground. The most positive effects of taping were seen in the swing phase. In stance phases, taping could not restrict excessive knee rotation and even increased it. Usually, taping acted during the swing phase because of the open kinematic chain in the gait cycle.

In summary, knee rotation was higher in the ACL-deficient subjects relative to the control group, but was significant only during activities on the treadmill. Both the FKB and the tape were helpful in reducing knee rotation mostly in the treadmill trials, and particularly while walking on the treadmill. During walking on level ground, the ACL-deficient subjects were able to control the excessive tibial rotation and no bracing or taping was required in these trials.

With the above findings, therefore, we can confirm that the positive effects of the FKB appear to be on reducing excessive tibial rotation during the walking trials. Taping, however, was only effective during the swing phase and while walking on the treadmill. The FKB could significantly reduce total knee rotation even in the more forceful activity of running on the treadmill.

6.2.1. 4. Translatory kinematics

Anterior-posterior (A-P) tibial translation is a linear movement of the tibia with respect to the femur. The amounts of A-P tibial displacements are controversial between researchers probably due to the methods of measurement used. While clinicians measure this component of translation at fixed knee angles, in this study it was studied during dynamic activities. The accurate measurement of tibial translation in dynamic activities is very difficult, as it is a combination of flexion/extension, gliding and rotation movements. Studying translatory kinematics of the knee as a static measurement is not logical as it does not include muscle activity which is the first defence line in all joint ligament injuries.

The main restraint to anterior displacement is the anterior cruciate ligament (Karrholm, 1989; Wojtys *et al*, 1987; Wojtys *et al*, 1996; Liu *et al*, 1995) and when the ACL is ruptured, the A-P displacement is increased. The increased A-P tibial displacement in ACL-deficient subjects has frequently been shown in the static situation in *in vivo* tests (Vergis & Gillquist, 1998; Vergis *et al*, 1997; Ishii *et al*, 1997; Bagger *et al*, 1992) or *in vitro* (Hirokawa *et al*, 1992; Marans *et al*, 1989; Noyes *et al* IN: Jonsson, 1989; Ann *et al*,

1993). However, during dynamic activities, the increase in the A-P tibial displacement and the amounts of that displacement are not clear. While the A-P tibial displacement in intact knees in an *in vitro* situation was measured as 6.3 ± 2.2 mm at 30° of knee flexion by Hirokawa et al (1992), Maran et al (1989) found it to be 7.6 mm and Bach (1988) reported 6.3 mm at low loads (89N).

The A-P displacements in an ACL-deficient knee *in vitro* was also reported as 7.8 mm by Bagger et al (1992) and by Karholm (1989) as 8.1mm. Vergis and Gillquist (1998) used an electrogoniometer and in an *in vivo* study during stair climbing in normal subjects found various A-P tibial displacements (1-12mm, mean 7mm). Ishii et al (Ishii *et al.*, 1997) found a peak value of 5.2 ± 1.7 mm A-P displacement during walking on level ground.

Gait analysis systems have occasionally been used to measure the A-P tibial translation. The best *in vivo* study in this area has been conducted by Lafortune et al (1992) on five healthy subjects during walking on level ground. They measured the anterior-posterior draws using a remarkably invasive method by inserting intra-cortical pins into the right anatomical plane site of tibia, femur and patella. They used four high-speed cine cameras and recorded movement taking into account all six degrees of freedom (three angulatory and three translatory planes) at the tibiofemoral joint. The pattern of tibial movement showed a striking similarity during flexion/extension of the tibiofemoral joint. When the knee flexed, the tibia experienced a posterior draw and when the knee extended the tibia moved anteriorly. The posterior draw amounted to 3.6 mm during stance and 14.3 mm during the swing phase. The anterior draw observed during stance forced the tibia to a position 1.3 mm past the neutral position (defined as 0 mm). The similarity between the draw of the tibia during flexion/extension of the tibiofemoral joint indicated that the draw motion was a function of the tibiofemoral joint angle. The pattern indicated that the curvilinear relationship between these two motions was altered when the tibiofemoral articulation was loaded as compared to when it was unloaded. The initial stance knee flexion (loaded phase) caused less posterior drawer than the knee flexion that occurred prior to toe-off.

As Lafortune et al (1992) showed the A-P displacement of the tibia is not a movement independent from the tibiofemoral joint. It occurs combined with flexion/extension of the tibiofemoral joint. Measurement of A-P tibial displacement in a static flexed knee

position either *in vitro* or *in vivo* is not an appropriate method to assess the A-P tibial motion as some important issues will be overlooked. The increased A-P displacement in the static method can be very different from subject to subject due to different ligament elasticity in the different subjects due to the test position, to psychological issues and to the gender of the subjects. Another important issue is that the increased A-P displacement in a static flexed position does not necessarily mean increased A-P tibial translation during dynamic activities. As Nemmeth et al (1997) has discussed, in dynamic activities, particularly in forceful activities, some compensatory events occur and cause the activity to be performed apparently normally even when the joint is abnormal.

To the best of my knowledge, there is no research in which the A-P tibial translation has been studied by an advanced gait analysis system in ACL-deficient subjects either in an invasive or non-invasive method. Andraicchi et al (1998) described a new method based on a Point Cluster Technique (PCT) to reduce the non-rigid body motion artefacts during *in vivo* human motion testing and to evaluate its applicability to *in vivo* testing.

They developed this method in order to measure the tibial motion non-invasively. This technique involved the placement of a cluster of reflective markers on the thigh and the leg. In this method, a femoral reference point (P) was located at the midpoint of the line connecting the lateral and medial epicondyles (virtual point). The displacement of point P relative to a reference frame fixed on the tibia was used to quantify the frame motion. They reported similar result to those found by Lafortune et al (1992).

In the present study, the shape of A-P tibial translation produced by the virtual marker method, as explained in 3.15 and 6.1.3, was very consistent particularly during treadmill trials and is in total agreement with that of Lafortune et al (1992). It also convinced me that the method used in this study is reliable and repeatable. A comparison of the results for the non-braced ACL-deficient subject compared with the control subjects and with the braced or taped ACL-deficient patients, should provide the opportunity to determine the effects of ACL-deficiency and the extent to which the brace or tape could control excessive tibial movements. However, it is important to mention that the amounts of A-P displacement that are recorded in this study are not pure tibial translation as mentioned in the literature. It is the translation of the tibial virtual marker relative to the femoral virtual marker in combination with other movements but these do allow us to compare the healthy and injured knees with each other and to study the effects of bracing or taping on

the ligament deficient knees. The higher amounts of tibial translation found in this study (relative to Lafortune's study (1992)) indicate this additional movements.

It is important to note that I did not use the absolute values for tibial translation and I did not focus specifically on this method to show pure tibial translation in the normal or ACL-deficient subjects. However, I have been able to use this method as a comparative method and it had been applied to the ACL-deficient and the control subjects. As a result, any confounding factors would be similar for the ACL-deficient subjects and the controls. Our method is very similar to that reported by Andriacchi et al (1998).

The alternative methods to a skin-based marker system are Stereoradiography (Jonsson & Karrholm, 1994), bone pins (Lafortune *et al*, 1992; Murphy IN: Andriacchi *et al*, 1998; Reinschmidt *et al*, 1995), external fixation devices (Cappozzo *et al*, 1996) or single plane fluoroscopic techniques (Sati *et al*, 1996). All of these methods are invasive or expose the test subject to radiation. Therefore, the wide spread applicability of these methods is limited.

Another non-invasive method of measurement of tibial movement has been reported by Cappozzo et al (1997). This was called the Calibrated Anatomical System Technique (CAST). They claimed that using this technique the marker artefacts were remarkably reduced.

The main difference between the current study and those carried out by Andriacchi et al (1998) and Cappozzo et al (1997) is that both these investigators tried to introduce a non-invasive method to measure the exact tibial displacements. Since tibial displacement is not an individual movement isolated from other motions of the knee and, skin artefact is still a problem, their methods have not widely been accepted within others using gait analysis.

Since a virtual marker method has been used in this study, it is important to emphasise that this method is not entirely new, other researchers have used it, and the validity of the method has already been confirmed. Attfield et al (1997) used an Elite gait analysis system and placed four markers on the lateral and medial condyles of the tibia and femur. Using a virtual marker method, they defined the tibial and femoral ACL points of attachment. To provide a non-invasive and *in vivo* description of the patterns of dynamic mechanical strain of the ACL strain associated with physiologic human movement, Attfield et al (1998) used the virtual marker method to locate the insertion point of the

ACL on the tibia and femur. They suggested that the virtual marker technology offered a potentially valid and useful technique for the non-invasive assessment of ACL function associated with physiologically valid exercise.

Rennie et al (1998) have also used the virtual marker method and has defined upper limb kinematics to provide a reliable objective measurement. Woledge¹⁰ et al routinely use virtual markers and have found them to be reliable and useful particularly in the shoulder girdle and knee joint area which are multi-axial joints. They used this method for studies of gleno-humeral and scapulo-thoracic motions².

Karrholm (IN: Jonsson *et al*, 1989) used Steinmann pins into the tibia and femur and found a more pronounced posterior tibial position on the injured side during active knee flexion, presumably due to simultaneously increased external tibial rotation and posterior displacement of especially the lateral tibial condyle. During walking on level ground and during the loading response, there is a backward translation of the tibia, which is followed by anterior translation in midstance. It then translates backwards during the rest of the gait cycle and peaks at around 70% into the gait cycle. Thereafter it translates anteriorly until it reaches its neutral level to be prepared for the next step.

The pattern of McCaly's A-P curves during running on level ground (McClay and Manal, 1999) were fairly similar for all conditions and they corresponded well with respect to the findings of Lafortune et al (1992). Higher magnitudes of anterior displacement were evident during running on level ground. The translation that occurred during running on level ground was similar to that of Lafortune et al (1992) and McCaly and Manal (1999) who associated flexion with tibial distraction and translations both medially and posteriorly with the reverse being true for extension. At heel strike, the origin of the tibial anatomical reference frame was posteriorly placed with respect to the femoral origin. A further posterior displacement occurred during the first 25-35% of stance when the knee flexed after which the tibial reference point was more anterior for the pathological group when compared with the normals. The ACL-deficient knees also exhibited greater anterior drawer but McCaly and Manal (1999) were unable to account for these differences between conditions.

¹⁰ Personal communications, September 1999, Professor Roger Woledge, Director and Professor of Experimental Physiology, Human Performance Laboratory, RNOHT, Stanmore, London.

It is interesting to note that, during the first 5% of stance, Reinschmidt et al (1997) observed negligible translations, which were followed by a posterior tibial displacement of 4mm between the origins of the tibial and femoral reference frames. From about 40-80% of stance, the tibia moved anteriorly (5mm) followed by a sudden posterior displacement towards the end of stance.

6.2.1. 5. Measurements of A-P Displacement in This Study

In the current study, an average kinematics of the tibiofemoral joint was obtained from three trials while walking on level ground. The tibia translated backwards with knee flexion and translated forwards when the knee extended. In the current study, the peak A-P tibial translation was measured during both the stance and the swing phases. The total translation was also calculated throughout the gait cycle as the difference between the maximum and minimum translation during the cycle. As for knee rotation, all A-P values, in this study, were normalised to the point of heel strike, which has defined as zero time. At heel strike, the tibia showed a posterior translation followed by an anterior translation in midstance. It then posteriorly translated again and reached its peak posteriorly at midswing, then came anteriorly as the knee extended and reached to the neutral position to be prepared for the next heel strike.

While walking on level ground, the non-braced ACL-deficient subjects showed an increase in their A-P displacement relative to the control subjects both in their stance and swing phases although the increase was significant only in the swing phase. During walking on level ground, the brace could significantly reduce the total A-P tibial displacement. The taping increased the A-P tibial displacement in the swing phase while walking on level ground rather than reducing it, which was considered to be a harmful result. The total A-P displacement measured in this study gave a better indication of the effects of the FKB or taping throughout the gait cycle. Significant differences were found between the non-braced ACL-deficient subjects and the control group ($P=0.010$) in terms of total A-P displacement while walking on level ground. This was in agreement with Jonsson and Korrholm (1990) who reported that a functional knee brace could reduce the A-P displacement, but not to normal level. Wojtys et al (1990), however, did not find a significant reduction of the A-P translation in ACL-deficient subjects with the 14 braces

they tested. This contradicted their previous report (Wojtys *et al*, 1987) in which they had claimed that the brace might be effective on reducing A-P displacement.

While walking on the treadmill, there were significant differences between the non-braced ACL-deficient subjects and the control groups. Wearing a FKB significantly reduced the A-P displacements in both stance and swing phases. Taping again increased the displacement of the tibia relative to the femur in both stance and swing phases. The greatest differences were seen during walking on the treadmill, which was related to the swing phase and a FKB controlled tibial movement was identified in this phase.

The pattern of A-P displacement was approximately similar between walking on level ground and walking on the treadmill. However, while running on the treadmill, this pattern was reversed during the stance phase. When running on the treadmill, in stance phase, the tibia had an anterior translation, instead of the posterior translation found in walking on level ground and on the treadmill. This was possibly due to the bouncing effects of jumping during running on the treadmill, which was explained in the ROM part of this Chapter (Page 230). The pattern of the rest of the A-P tibial displacement was similar to that of walking on level ground and walking on the treadmill during the swing phase.

While running on the treadmill, the ACL-deficient subjects showed higher A-P displacements in both stance and swing phases relative to the control subjects. This reached to a significant level only during the swing phase. Wearing a FKB significantly reduced the A-P displacements of the tibia relative to the femur in the stance phase.

Beynon and Johnsson (1996) pointed out that in ACL-deficient knees in an open kinetic chain (when the foot is not on a surface such as the ground) the A-P displacement is greater. However, performing a closed kinetic chain makes an A-P displacement similar to the healthy knee and this is the basis of new aggressive rehabilitation for ACL-deficient knees. In our study, the greatest A-P displacement occurred in the swing phase when the knee was in an open kinetic chain situation. During stance phase, the A-P displacement was so low that it was not possible to identify any effect of the brace.

In summary, we can confirm our hypothesis, that the FKB is effective in reducing A-P displacement of the tibia relative to the femur in low load activities such as walking on level ground and walking on the treadmill. However, during high force activities such as running on the treadmill, a FKB may not be as effective. Our findings are in disagreement

with Liu (Liu *et al.*, 1995) who reported the positive effects of FKB only in the high load (250N) and not at low loads (25N). However, our findings are in agreement with Beynnon *et al* (1992), Beck *et al* (1986), Colville *et al* (1986), Rink *et al* (1989), and Branch *et al* (1988) who reported that the brace might be effective during low load activities, but not at higher load activities. It is important to remember that, contrary to the above studies, our findings have been derived from dynamic *in vivo* tests, which are more valuable than static *in vivo* tests.

6.2.2. Kinetics

The study of joint kinetics is important because it provides insight into the function of muscles involved during activity. An estimation of the internal muscle moments that cause joint motion may be obtained through inverse dynamics using the combination of kinematic and ground reaction force data (Winter, 1987). The pattern of change in the joint moment reflects some of the underlying patho-biomechanics of the knee joint (Andriacchi, 1990). Although it is muscle forces that cause the body to accelerate (force equals mass times acceleration), these muscle forces are difficult to accurately measure (McClay, 2000). However, the acceleration of the body can be measured by recording the movement patterns of the body during motion. Because acceleration is measured and forces and moments are derived mathematically, this process is called inverse dynamics. Moments alone do not provide information about the manner in which the muscle is functioning. Joint power can be determined by multiplying joint moment by angular velocity.

Biomechanically, in the knee joint, there must be a balance between the external moments that tend to flex the knee (which can be measured in the laboratory) and the net internal moment that is generated by contraction of the quadriceps. If a concurrent contraction of the quadriceps and the hamstrings occurs, the net internal moment is the difference between the internal moment that was produced by the quadriceps force and that produced by the opposing hamstring force. Therefore, if such concurrent contractions do occur, a net internal quadriceps moment would imply that the internal moment that was generated by the force in the quadriceps was greater than the moment that was generated by the hamstrings.

The internal moment that balances the flexion moment (that is the moment that is provided by the quadriceps) actually reflects the net effect of the internal moments that

are generated by the quadriceps and hamstring muscles (the extension moment produced by the quadriceps the flexion moment produced by the hamstrings), since simultaneous contraction of these muscle groups is possible. It is interesting that the most important and significant kinetic findings are in the sagittal plane (Novacheck, 1995).

Some researchers name the moment by the external force creating it. Because muscle moments and power generations are directly related to body weight, all data are normalised by body weight. In the current study, the unit of moments is Nm/Kg and the unit of power is W/Kg.

It is important to understand that all moments reported in the present study are internal moments. For instance, in the knee joint the moment reported for the quadriceps muscle is the internal extension moment.

The internal knee moment changes from a flexion moment just after heel strike (initial knee flexion moment), to an extension moment at the end of loading response or at the beginning of midstance (early midstance knee moment), to a flexion moment during terminal stance (terminal stance moment), to an extension moment during pre-swing (pre-swing knee flexion moment). To prepare the knee for initial contact, the hamstrings become dominant in the second half of the swing phase producing a knee flexor moment. Shortly after the initial contact, the quadriceps become dominant, producing a knee extensor moment. The analysis of the quadriceps avoidance gait pattern was based on the early midstance knee moment (Berchuck *et al*, 1990; Wexler *et al*, 1998). In other words, if the external moments are proposed during walking on level ground, the moment about the knee changes from one that tends to produce extension at heel-strike, to a flexion moment at midstance, to an extension moment in late mid-stance, and finally to a flexion moment near toe-off. In midstance, no net quadriceps (extension) moment is necessary.

The knee extension in swing phase (following the reversal point i.e. when the moment changes from positive to negative) is a passive phenomenon and is due to the inertia of the leg (tibial segment). It is resisted and controlled by eccentric hamstring contraction. This is seen as a knee flexor moment and a power absorption in terminal swing (Novacheck, 1995). The hamstring activity fades shortly after initial contact and is supplanted by a stance phase knee extensor moment (quadriceps).

The knee extensor moment is continuous into the swing phase to the reversal point (eccentrically controlling knee flexion). The eccentric activity is seen as power absorption during the initial swing phase.

In the present study, four values were measured - the maximum knee extension moment; the maximum knee flexion moment; the maximum generation power; and the maximum absorption power.

As Figure 5-10 (middle picture) shows, in the present study, some parts of the knee moment graph did not correspond to the pattern and values of the moments reported in the literature. It was found that the values of knee moments in our subjects (both the ACL-deficient and the controls) between 20% and 65% of the gait cycle (pre-swing) was higher than those reported in the literature. The early stance and the terminal stance knee moments remained intact. Even though the moments in these two sections have been modified possibly by a Centre of Pressure (COP) problem, since the problem occurred in both groups of subjects equally, the data is still valuable for comparison of the moments and power between the groups to find the effects of a knee support such as a FKB or taping.

As the kinetic Tables and Figures showed, the maximum moments were not significantly different within the ACL-deficient groups when all knee supports were compared altogether. However, the ACL-deficient subjects showed less knee extensor moment than that of the control group but this was not significant. Wearing a FKB reduced the knee moments even more but the differences again were not significant. Our findings for reduction of knee moment in the ACL-deficient subjects and after bracing are in agreement with those reported by DeVita et al (1992). No significant differences were found within the ACL-deficient subjects. Taping also reduced the knee moments although it was less than that which occurred following bracing. Reduction of knee extensor moments seems to be due to lower levels of activity of the knee muscles following bracing or taping. Both knee generation muscle power (concentric contraction) and knee absorption muscle power (eccentric contraction) were reduced in the ACL-deficient subjects in this study. The area under the curve also showed a reduced knee moment in the ACL-deficient subjects with respect to the control group but this difference was not significant.

Therefore, in spite of the existence of reduced quadriceps activity in four patients in this study (26% of the patients), the so-called quadriceps avoidance gait QAG pattern,

introduced by Berchuck et al (1990), was not confirmed. Our findings are in agreement with Kadaba et al (IN Roberts *et al*, 1999) and Beard et al (1996) who reported no quadriceps avoidance gait pattern in their studies. They reported a flexed knee position combined with internal knee extension moments throughout the stance phase. The flexed knee position was also confirmed in the current study, which was combined with knee extension moments. All of our patients, even those who showed a reduced quadriceps activity, had a knee extension moment throughout stance. Our results, therefore, confirmed the Roberts's findings (1999) that reported no QAG pattern in any of their ACL-deficient subjects during walking on level ground. They also reported, as we have, a net internal extension moment throughout the stance phase.

Some researchers (Torry *et al*, 2000) believe that ACL injured and ACL reconstructed individuals tend to have residual quadriceps weakness (particularly weakness of the vastus medialis) long term after their injury or surgery. This weakness has been shown to affect the lower extremity gait in these individuals. Vastus medialis insufficiency due to afferent inhibition would contribute to abnormal patellar tracking and possibly result in retro-patellar pain or re-current bouts of knee joint effusion which may account for some of this residual weakness, leading to on-going extensor mechanism dysfunction. The bi-articular hamstrings, like the rectus femoris play a role in energy transfer between segments. The hamstrings and the gastrocnemius both have important eccentric and concentric functions while the hip extensors probably function only concentrically.

The amount of eccentric and concentric work done can be derived by calculating the area under the related curve. In the current study, the area under the curve of "joint power" showed a reduced positive power, which was not significant. DeVita (1992; 1998) also reported no significant difference in the moments or total joint power in the reconstructed knee during running on level ground.

Our data contradicts Berchuck's finding (1990) in that it did not show any QAG pattern. The reason that our data did not support Berchuck's findings of 75% reduced moments in ACL-deficient subjects may be related to their subjects time from injury. Although Berchuck found no relationship between the time post injury and reported that the QAG occurred equally in the acute and chronic ACL-deficient subjects (Berchuck *et al*, 1990), Birac et al (1999) reported a higher incidence (up to 80%) of the QAG in patients more than 6 years injury. They have also reported QAG in 44% of the subjects who were

assessed less than 1.5 years after injury. In our study, the mean time post injury was 43.7 ± 32.5 months and this might explain the absence of QAG in most of our subjects.

In summary, the observed flexed knee angle and the non-significantly reduced knee moments in our study convinced us that our patients compensated for their injury with a greater knee flexion angle at heel strike and midstance along with the earlier activation of the gastrocnemius muscle. The lower extensor knee moment might be explained by a combination of an increased knee flexion angle during the weight acceptance period and a lower impact ground reaction force due to the slower speed that they chose while walking on level ground. Wearing a FKB reduced knee moments non-significantly. This might indicate that the brace can be helpful for ACL-deficient knees by reducing the requirements for muscle activity including normal activity of the quadriceps muscles. The EMG data showed that the changes of both quadriceps and hamstring EMG activities were not significant following the bracing. The taping showed the same phenomenon as bracing in terms of kinetic changes and also reduced knee moments, although less marked than with the brace.

Although there is a trend towards a reduction of knee moments with both the FKB and with taping, we have been unable to prove our hypothesis because the reduction was not significant. This could be due to a type II error (A type II error results when the *P* value fails to reach statistical significance even though the underlying groups are truly distinct).

Regarding the ankle and hip moments and power in our study, a non-significant difference was found between the non-braced ACL-deficient and the control subjects in terms of ankle moments. The area under the curve also showed a non-significant increase in the ankle angular impulse in the non-braced ACL-deficient subjects. Wearing a FKB or taping increased the ankle angular impulse while it reduced knee moments simultaneously, although the differences were not significant for any of these changes. The overall ankle moment in ACL-deficient subjects with different supports showed no significant differences.

The ACL-deficient subjects showed a lower ankle generation power during walking on level ground, which decreased when wearing a FKB. Taping, however, significantly increased both the generation and absorption of ankle power. The absorption power was greater in the non-braced ACL-deficient subjects than in the control group. Bracing even increased it, which might indicate a reduced need for concentric but an increase need for eccentric muscle activity following the bracing.

In the hip joint in our study, the ACL-deficient subjects showed a lower maximum hip moment and power than that of the control subjects. They showed a lower maximum hip extension and flexion moments which were significant only for the hip extension moments. The generation power was smaller in the ACL-deficient subjects than in the normal group. The greatest differences were found in the absorption hip power, which occurred during midstance to toe-off. This value was significantly greater for the ACL-deficient subjects. There was a significant difference in hip extension moment between the non-braced ACL-deficient subjects and the control group subjects. This increased while wearing a FKB and improved towards normal values. This might indicate that wearing a knee brace reduces knee extension moments but increases hip extension moments, which might indicate a compensatory effect of knee bracing. Taping, however, reduced hip extension moment even more and did not show any compensatory effects.

Only taping (and not bracing) significantly increased the area under curve for power of the ankle and hip joints in the ACL-deficient subjects. This might indicate that the patients did not trust the taping and used more muscle activity to stabilise their lax knee. In other words, when tape was used, the subjects used more (although non-significant) ankle and hip muscle activity and compensated the existence of lower knee muscle activity although this was not significant and neither were the angular impulse recorded about the knee joint.

In summary, our ACL-deficient patients showed reduced moments at the knee and hip joints and wearing a FKB reduced the moments at the knee joint but increased the hip extensor moments. The "support moment (support torque)" for the non-braced ACL-deficient subjects was much less than that of the control group (1.62 vs. 1.85 Nm). The "support moment" in the braced ACL-deficient subjects reduced to 1.50 Nm, but taping did not change it and remained unchanged following knee taping. This clearly shows that: 1) the ACL-deficient subjects used less muscle activity in their whole lower limb than that of the control subjects; 2) only the FKB (and not taping) reduced muscle activity more and indirectly showed that the brace worked instead of muscles to give more stability and confidence to the patients.

The "support power" in the control subjects was positive (generative), whereas it was negative (absorptive) in the ACL-deficient subjects with different supports. In other

words, the control subjects used more concentric muscle contraction in their lower limb muscles but the ACL-deficient subjects showed more eccentric muscle contraction. Both bracing and taping decreased the negative power in the lower limb in the ACL-deficient subjects, which is another reason why using orthoses (bracing > taping), the subjects would need to use less muscle activity.

In conclusion, an observed flexed knee during walking on level ground in ACL-deficient subjects led to some kinetic alteration throughout the lower limb. A non-significantly reduced knee extensor moment, a lower ankle dorsiflexion moment, lower hip extensor and flexor moments, lower "support moment" together with lower generation and absorption power in ACL-deficient subjects highlighted that ACL-deficient subjects used less muscle activity than that of the control subjects throughout the stance phase. Wearing a FKB reduced the knee extensor moment, ankle dorsiflexion moment, and hip flexion moment and power as well as increasing the hip extensor moments. Taping, however, had no significant effects on the knee joint, but increased the ankle absorption and generation power, and the decreased hip generation power. Bracing reduced the "support moment" in the lower limb, taping did not change it. Either bracing or taping increased the "support power" in the ACL-deficient subjects but only in eccentric form which is important for shock absorption, although it did not reach normal levels. Wearing a FKB clearly showed less need for muscle activity in lower limb as a whole, particularly about the knee joint area.

6.2.2.1. Adaptations in the ACL-Deficient Knees in This Study

The biomechanics of the functional adaptations were analysed to show that when subjects modify their function, the strains in the secondary restraints to anterior draw at the knee are substantially reduced. The nature of the adaptation also suggests that there is a dynamic reprogramming of the locomotor system in some subjects, but not in others. An understanding of the biomechanics and functional implication of these adaptations can be applied to methods for rehabilitation as well as treatment planning for patients with ACL-deficient knees.

Different ACL-deficient subjects may adapt in different ways to their injury and show different compensations. In the current study, the subjects showed a flexed knee during the weight acceptance period to mid-stance (either in high-speed running or during treadmill walking when compared to level ground), flexed hip posture, and subsequently a reduced hip and knee extension moments, which were further reduced when the patients

used a FKB. The increased ankle plantar flexion angle indicated a greater ankle plantar flexion moment that consequently increased the gastrocnemius activity. This was also demonstrated by increased EMG activity in the gastrocnemius muscle and the earlier activation of this muscle during gait all of which are assumed to be adaptations of muscle functions during walking on level ground.

The ACL-deficient subjects, in our study, always showed a greater knee flexion angle as the speed of movement increased. Their remarkable increase in the knee flexion angle during running on the treadmill confirms the adaptations occurred to their knee when compared with the control group. The same increase occurred when the surface of movement changed from level ground to the treadmill. We, therefore, believe that adaptation occurs either when the speed increases or when the surface changes from stable level ground to an unstable surface such as the treadmill.

The ACL-deficient subjects in this study did not show any QAG pattern, which is a controversial gait adaptation found in some ACL-deficient subjects.

In a recent study, Patel and Hurwitz (1999) found two mechanisms that the ACL-deficient subjects used to produce QAG in their study. They reported that in patients who showed a QAG pattern, 72% had a knee flexion at midstance and did not use their quadriceps muscles. They found that the remaining 28% avoided using their quadriceps by increased hip flexion. In other words, they used a forward lean position to reduce quadriceps activity.

Beard et al (1996) postulated that the increased knee flexion angle can be part of a compensatory mechanism which attempts to stabilise the ACL-deficient knee. The increased knee flexion allows the hamstring muscles, acting across the knee joint, to have a greater force component horizontal to the tibial plateau and therefore be more effective in reducing sagittal subluxation of the tibia in relation to the femur. They also found that the patients who most commonly used a flexed knee gait used their hamstring muscles the longest. Our findings confirmed that ACL-deficient patients showed significantly greater knee flexion at mid-stance.

We also investigated the parameters of either knee angle at midstance or the time to reach midstance. The ACL-deficient subjects reached midstance significantly later than that of the controls (32.1% vs. 30.1% of the gait cycle) and showed a greater knee flexion angle at midstance (13.8° vs. 10.7°) which we believe reflects more instability in the ACL-

deficient knees. Wearing a FKB did not change either the knee angle or the time to reach midstance. However, while taping, the subjects showed even greater knee flexion angles at midstance, and were significantly delayed in reaching midstance, which again exhibits a more unstable knee. The findings confirmed that no alterations occurred in the adaptation of the ACL-deficient patients following either FKB or taping. We, therefore, assume that in addition to the angle of the knee at midstance, the time percent in the gait cycle in which the knee reaches the midstance is also important. The increased time to reach midstance, we believe, indicates the greater instability of the knee.

Although a flexed knee was present in our patients during walking on level ground, the investigator of the current study doubts if the flexed knee can lead to a more stable knee as Beard et al (1996) postulated. It is well known that the flexion position of the knee is a loose packed position and is very unstable (Kapandji, 1987). Although the flexed knee provides a better biomechanical angle for the hamstring muscles to effectively hold the tibia back, it exposes the knee joint to an unstable position, which may lead to further twisting injuries, particularly in stressful activities such as the side-step cutting manoeuvre or while running on the treadmill. I believe that if the quadriceps avoidance gait occurs, even during walking on level ground, the flexed knee can not be a protective mechanism for these patients. The flexed knee can play a role as a protective mechanism in ACL-deficient knees only if the quadriceps muscle is active throughout the stance phase, as it was in our study. Thus, even though the net internal (i.e. muscle) moment may be a net flexor moment, this does not mean the quadriceps muscle is not producing a force. It means that the moment produced by the quadriceps is less than the combined moments of the hamstrings, gastrocnemius, and other secondary knee flexors. Therefore, I doubt if, the title of "quadriceps avoidance" is a correct name for this phenomenon. Devita et al (1997) showed that recently injured ACL-deficient subjects had a gait pattern opposite to the quadriceps avoidance pattern: they had a net extensor moment throughout stance. Therefore, the activity (not over-activity) of the quadriceps muscles is necessary to work in conjunction with the hamstrings and the gastrocnemius muscles to actively compress the knee and provide a better and more stable joint position.

With regard to the above findings, we can justify the reason why the QAG pattern may not occur in our study, and we noted our patients showed remarkable quadriceps activity in midstance. This is in agreement with Roberts et al (1999), Hassan et al (1991) and Kadaba et al (IN Roberts *et al*, 1999).

The controversy over whether compensatory mechanisms for ACL-deficient knees originate from higher neurological centres (e.g. a learned response) or from peripheral mechanical and/or neurological adaptations is unknown. Beard et al (1996) postulated that a symmetrical adaptation during gait would suggest dominance of high neurological centres, (responsible for central coordination and movement patterning), over possible peripheral compensatory mechanisms in the ACL-deficient subject. Asymmetrical gait patterns are perhaps suggestive of compensatory mechanisms at a lower or peripheral level.

6.2.3. Force

The double peaked configuration observed in the vertical force of the ground reaction force (GRF) in this study was characteristic of those in previous literature (Perry, 1992; Perry, 1990). The so-called "impact peak" was followed by a decrease to a relative minimum and a subsequent rise to a second peak (designated vertical active force) in the force record. The force data was normalised across subjects by dividing the individual's weight by the entire stance time (Newtons per Kilogram Body weight, N/Kg-BW). As a standard approach in force studies (DeVita *et al*, 1997; Munro *et al*, 1987; DeVita *et al*, 1998; DeVita *et al*, 1992; Knutzen *et al*, 1983; Knutzen *et al*, 1987; Ramsey *et al*, 2001), only the vertical or impact force (Z) and the anterior-posterior shear force (X) data were analysed in this study.

The non-braced ACL-deficient subjects showed a lower peak impact force and reached the peak point later relative to the control group. Both the bracing and the taping conditions significantly decreased the impact force values ($P=0.009$, $P=0.01$, respectively) showing a positive effect for the injured knee. For the ACL-deficient subjects no significant difference was found in the impact force values during walking on level ground.

In 1989, Cook et al (1999) studied 14 ACL-deficient subjects who had been acclimatised with bracing for six months and studied the force during running and cutting with and without bracing. He reported a general increase in the force following bracing. Knutzen (1983; 1987) also reported an increase in the GRF during walking on level ground which he attributed to the increased speed of walking after bracing. In our study, we believe that the overall reduction in the GRF during the first half of the stance phase was the result of

an attempt to reduce impact on the limb in the injured subjects. The lower peak value will reflect a lower rate of loading and a gentler placement of the foot on level ground.

It is important to understand that, in the present study, the ACL subjects chose to walk slower and they did this by exerting less force on the ground. Kiefer et al (1985) reported a decrease in the maximum lateral reaction force during walking on level ground. In our study, we identified a lower posterior shear force (propulsive shear force) in the non-braced ACL-deficient subjects relative to the control subjects. This was significantly reduced after either bracing or taping. This might mean that both the brace and tape conditions worked instead of the propulsive muscles and reduced the forces on the injured knee. We, therefore, found the brace or tape benefited the ACL-deficient subjects by reducing both the impact and the posterior shear force. This contradicts Ramsey's findings (2001) who reported a non-significant increase in the impact force in ACL-deficient subjects during a jumping test and concluded this was a harmful effect of bracing. Ramsey concluded that bracing may increase the risk of injury in ACL-deficient knees. In our opinion, the increased GRF during a jumping test may be a consequences of various factors including the different speeds and accelerations of the subjects before jumping, the maximum height of jumping just before landing, and particularly, the inclination angles of the subjects before landing.

The results of our study are in agreement with Rudolph et al (1998) who found a lower vertical GRF in both "coper" and "non-coper" ACL-deficient subjects. The average Lysholm score in our subjects showed that they were in the category of "non-coper" subjects.

It is important to remember that, in all tests and activities, all of our ACL-deficient subjects (except two who were not able to run) behaved very similarly and being categorised as a "coper" or "non-coper" subject was not a significant factor in their ability to carry out their tasks. For instance, of four subjects who showed a quadriceps reduced activity in early stance, only one of them was in the "non-coper" group and the others were in the "coper" group.

Carlsoo and Nordstrand (IN: Branch *et al* 1989) found no significant difference in impact force between normal and ACL-deficient subjects during running on level ground. Similar result was reported by DeVita et al (1992) in his ACL-reconstructed subjects. Our

findings are also in agreement with Hassan et al (1991) who reported a reduced impact force in ACL-deficient subjects during standard pivoting tests. The lower impact force in our subjects may be partly due to their slower speed of walking rather than a compensatory reaction.

With regard to the above findings, we confirm that bracing does not appear to be harmful for the ACL-deficient knee and even helped them by encouraging a lower walking speed and consequently reducing the forces on their injured knee. Bracing changed the style of walking in the ACL-deficient patients and altered it to a more normal style.

6.2.4. Electromyography (EMG)

For many years, several researchers have studied the application of EMG for the assessment of lower extremity muscle function. Dynamic EMG allows us to examine the patterns of muscle activity during movement. It has been applied to normal and pathological gait in clinical practice to determine phasic patterns of activation for individual muscles or muscle groups (Murray *et al*, 1984; Sutherland & Hagy, 1972).

Interpretation of the biomechanical data alone e.g. kinetic data without EMG findings does not give the researcher a comprehensive idea of what is actually happening and is sometime deceptive (DeVita, 2001). Without information about exactly which muscles are active and when, the calculated joint kinetics must be considered cautiously (McClay, 2000). For example, an extension moment that is calculated at the knee may be the result of the extensor muscles acting alone or having greater activity than the flexor muscles. The EMG, therefore, helps to improve the interpretation of these data.

The majority of studies using EMG during walking or running have utilised surface electrodes (Nilsson *et al* IN: McClay, 2000; Beard *et al*, 1994; Beard *et al*, 1996; Shiavi *et al*, 1992; Shiavi *et al*, 1987; Clarys & Cabri, 1993). Using the surface EMG electrodes has been proven to provide reliable data in electromyographic studies (Winter, 1979; Winter, 1990).

In the present study, the surface EMG electrodes were used to investigate the activity of four lower limb muscles in different test modes with different supports.

Standardisation of the quantified EMG data is also very important in comparing the EMG activities of one muscle relative to other muscles in that group or in an opposite group. In the present study, to reduce errors and to avoid false conclusions, both the peak and root mean square (RMS) values of the EMG signals have been calculated. Finally, the peak

and onset activation time of the gastrocnemius muscle as a key muscle in the ACL-deficient knees have been discussed individually.

Level Ground

During walking on level ground, the quadriceps and hamstring muscles have been noted to have EMG profiles which show increasing activity beginning in terminal swing and continuing through the loading response phase. During terminal swing, the quadriceps muscles were extending the knee, while the hamstring muscles were decelerating the thigh and preventing knee hyperextension.

In the present study, although the peak and RMS values gave the investigator a reasonable idea of the magnitudes of activity of the muscles, they did not provide the duration of each signal of a muscle over a gait cycle, which has been reported in some papers (Beard *et al*, 1996, Roberts *et al*, 1999).

During walking on level ground, the peak and RMS of the vastus medialis and the rectus femoris muscles decreased non-significantly in the ACL-deficient subjects. This is in agreement with Branch *et al* (1989) who reported a 30% decrease in the area under curve and 11% decrease in the peak of quadriceps muscle activity during a cutting manoeuvre. This also confirmed the quadriceps reduced (and not avoidance) activity in our subjects that has been mentioned in the kinetic findings. The peak activity of the flexor muscle group was, however, increased non-significantly (the gastrocnemius muscle increased 8% and the medial hamstring muscle showed a slight increase in peak activity). None of the four muscles studied showed any significant changes between the ACL-deficient and the control subjects in terms of the peak and the RMS.

Branch *et al* (1989) also reported a 46% increase in hamstring activity that they concluded was related to the ACL-deficiency. In the present study, we did not find any significant differences within the ACL-deficient subjects during walking on level ground. Neither a FKB nor taping effectively changed the peak or RMS of the muscle activities.

The FKB increased the activity of the vastus medialis, and decreased the activity of the other three muscles during walking on level ground. Taping decreased the peak and RMS of all four muscles. All changes were non-significant following either bracing or taping. The only significant change was seen in the rectus femoris muscle in which both the peak and RMS were significantly decreased in the ACL-deficient subjects following taping.

This, however, was not changed following the bracing. It seems that this decrease might be due to the physical compression of taping on the belly of the rectus femoris muscle.

Muscle activity during normal walking and running on the ground has been well documented. Wojtys et al (1996) pointed out that since the lower extremity muscles are the most important stabilisers of the knee, it is also important to consider the effects of bracing on lower extremity muscle performance. Nemmeth et al (1997) reported an increase in muscle activity in the EMG during non-braced conditions for ACL-deficient knees. The brace on the injured knee resulted in an increased EMG activity at midstance. They found that the hamstring muscles and the medial gastrocnemius muscle peaked at above 50% just before maximal knee flexion. They found an increased semimembranosus muscle activity of the injured leg without bracing and an increase in the biceps femoris EMG activity when using the brace.

Carlsoo and Nordstrand (IN Branch *et al*, 1989) found no consistent differences in the muscle firing patterns between a group of unilateral ACL-deficient subjects and a group of normal subjects during walking on level ground. However, Tibone et al (IN: Branch *et al*, 1989) used a traditional "on/off" dynamic EMG technique to study the unilaterally ACL-deficient subject during walking, running and stair climbing. The results showed that the medial hamstring stayed "on" longer in the stance phase of straight ahead running. During stair climbing, they found an earlier cessation of the vastus medialis obliquus in the involved limb than in the uninvolved limb as the body weight was being raised after contralateral toe-off. Branch (Branch *et al*, 1989) showed significantly greater activity in the ACL-deficient patients than in the controls during the swing phase in preparation for the cut (in a cutting manoeuvre) while the medial hamstring showed a significantly greater activity during the cut/stance phase itself.

The medial hamstring in the ACL-deficient subjects in our study also showed more stance phase activity than that of the normal knees, confirming the results of both Tibone et al (IN: Branch *et al*, 1989) and Branch et al (1989). This suggests that the medial hamstring may be an important antagonist to a pathological anterior draw created by active quadriceps contraction. This has also been emphasised by Beard et al (1996, 2000). During the swing phase in an ACL-deficient limb, Branch et al (1989) reported increased activities of the quadriceps, lateral hamstring and the medial gastrocnemius. In our study, the activities of the gastrocnemius muscle increased during late swing in the

ACL-deficient subjects during walking on level ground. Our finding is supported by some studies in the literature.

The hamstring muscles have long been considered as the most important muscle group in patients with ACL-deficient knees because of their ACL antagonist ability. But investigations by Lass et al (1991) highlighted the importance of the gastrocnemius muscle in stabilising the ACL-deficient knee. The functional role of the quadriceps muscle in an ACL-deficient knee, however, remains poorly defined. In simple terms, the quadriceps muscle is an ACL antagonist. Therefore, isolated, strong, quick quadriceps muscle contractions seem inappropriate. However, true isolated quadriceps muscle responses probably rarely occur *in vivo*.

Balanced quadriceps muscle activity is required in the ACL-deficient knee to restore a normal gait pattern after ACL injury (Frank *et al*, 1992), but eccentric quadriceps muscle function plays an important role in shock absorption during axial loading of the lower extremity. Because very little is known about the effects of combined muscle activity patterns, further investigation is needed into the effects of co-contraction in the ACL-deficient knee.

There is some variability in gastrocnemius EMG activity in the literature (Soundarapandian, 1992; DeVita, 2000). Some people have none or low gastrocnemius EMG in early to midstance and then have the normal EMG burst in late stance. Others have more EMG throughout the stance phase and even start the gastrocnemius EMG in very late swing.

In the current study, the gastrocnemius muscle showed a consistent activity in subjects during all modes of tests. While walking on level ground, the gastrocnemius muscle activated after the loading response and peaked at about 40% of the gait cycle. Therefore, the muscle was active between 20% and 50% of the gait cycle. No activation was found during heel strike or during the swing phase. In the ACL-deficient subjects, the muscle showed a higher peak activity and was activated earlier (i.e. it had a reduced onset activation time).

While walking on the treadmill, the trend of muscle activity was very similar to that of walking on level ground. It started at around 17% into the gait cycle and finished at

around 50% of the gait cycle. It peaked at approximately 40% of the gait cycle. The ACL-deficient subjects showed a higher peak and a reduced onset activation time. Therefore, the gastrocnemius muscle was active between 17% and 50% of the gait cycle while walking on level treadmill.

During running on the treadmill, there were two separate activity portions during a gait cycle. The first part lasted around 0-30% of the gait cycle and the second part started from 70% of the gait cycle and lasted up to the end of the gait cycle. Indeed, during running on the treadmill the gastrocnemius was activated at around 70% of the gait cycle in the swing phase and continued until the start of the stance phase. It remained active throughout stance, which was very short (25% of the gait cycle) during running trials.

Therefore, the above findings might explain the controversies mentioned by Soundarapandian (1992) and DeVita (2000). It seems that the whole duration of activity of the gastrocnemius muscle is dependent on the speed of the test. Different types of activities in different subjects might be related to their different speeds. The higher the speed, the earlier the activation, and probably the longer the duration of the gastrocnemius myoelectric signals.

The reason why the ACL-deficient subjects showed a strong gastrocnemius activity might be due to the larger output from the gastrocnemius, which is thought to be more beneficial for the ACL-deficient subjects. The larger force will: 1) compress the knee joint more and increase knee stability, 2) provide a small amount of posterior force to reduce the load on the ACL-deficient knee, and 3) compensate for the reduced quadriceps output to enable these people to walk or run better.

We also studied the peak and the onset activation time of the gastrocnemius muscle (the percentage period in the gait cycle in which the muscle starts activity) in all modes of tests. The largest changes occurred during walking on level ground. During all levels activity, the peak of the gastrocnemius increased remarkably, but not significantly, in the ACL-deficient subjects. During walking on level ground, the peak of the gastrocnemius muscle in the non-braced ACL-deficient subjects increased by more than 33% and was activated 29% earlier when compared to the control group ($P=0.002$). Either the FKB or the tape could reduce the peak but not statistically significantly (mean=6%). They both, however, did reduce the onset activation time of the gastrocnemius muscle significantly

($P=0.001$). Generally, there were significant differences in terms of onset activation time in the gastrocnemius muscle during walking on level ground between the ACL-deficient subjects with different supports and the control group ($P=0.0001$).

The ACL-deficient subjects always presented greater but non-significantly peak activity, but with a significantly less onset activation time. Either the bracing or taping similarly reduced the peak although it has not reduced to a normal level. The gastrocnemius muscles started activity significantly earlier following the bracing or taping indicating a complementary action to the ACL-deficient knees to make them more stable. This was emphasised by the leg having greater ankle plantar flexion and knee flexion angles in the ACL-deficient subjects.

Lass et al (1991) was the first to point out the important role of the gastrocnemius for ACL-deficient knees. He reported a substantial alteration in timing, as well as peak activity. Contrary to Lass et al (1991) the increased activity in the gastrocnemius muscle was not significant in the ACL-deficient subjects in our study, which was probably due to the lower speed of walking in our subject (3.6 Km/hr vs. 5 Km/hr in Lass's study). The peak was significantly higher for our ACL-deficient subjects only during running on the treadmill.

The gastrocnemius muscle acts across two joints. At the knee joint, it is primarily a flexor muscle and at the ankle joint, it is a plantar flexor. But, from the anatomical point of view it may also be an important muscle contributing to reduction of knee joint laxity. Markolf et al (1978) showed that a simultaneous contraction of the knee muscles increased the stiffness of the knee joint on average by a factor of 2 to 4 times and anterior-posterior laxity was reduced to 25 to 50 percent of the normal value. Lass et al (1991) considered the altered gastrocnemius function, together with alterations in thigh muscle activation, to be an attempt to stabilise the knee joint, which otherwise would be susceptible to subluxation.

In our study, the duration of each EMG signal was not measured due to the limitation of the software, although the RMS can somehow represent the whole duration of signals in a gait cycle. However, Beard et al (1996) found that the ACL-deficient subjects had a significant increase in knee flexion angle on their injured side at both foot contact and midstance. He also found that the hamstring EMG was higher in the ACL-deficient knee

than the normal side, but the quadriceps was similar in both groups. He found a correlation between the duration of hamstring activity signals and the knee flexion angle at heel strike. Perry (1990) reported a premature contraction in the vastus medialis muscle and the lateral hamstring. Roberts et al (1999) also reported a prolonged duration of co-contractions of the quadriceps and hamstring muscles throughout the stance phase. Her EMG data showed an increase in duration of quadriceps muscle activity in 94% of ACL-deficient subjects and an increase in medial and lateral hamstring activity in 94% and 83% of subjects, respectively.

Limbird et al (1988) found that most differences occurred in two transitional stages; heel contact and toe-off. They found reduced muscle activity in the rectus femoris, the vastus lateralis and the gastrocnemius muscles and increased muscle activity in the biceps femoris muscle during the heel contact phase. During the toe-off period, all muscles showed baseline activity at heel off. At toe-off, the quadriceps muscles had greater activity and the hamstrings had less activity than that of normal subjects. In this study, since the maximum amplitude and the RMS of EMG signals were calculated throughout the gait cycle, we could not differentiate the phases during which the largest changes occurred.

Level Treadmill

-Walking on the Treadmill

The shape and pattern of EMG signals in trials on the treadmill were very similar to those found on the level ground studies. The activity of the vastus medialis and the rectus femoris muscles were less in the ACL-deficient subjects than the controls (33.3% and 21.3%, respectively) as seen on level ground walking, although the difference was not significant. However, contrary to the level ground data, the hamstring activity decreased 18.4% and was less in the ACL-deficient subjects than in the control subjects. This was contrary to our expectations as the ACL-deficient subjects had more knee flexion angle during walking on the treadmill, which should result in more hamstring activity. However, this unexpected result might be due to the lower speed of walking on the treadmill (1 m/sec vs. 1.3 m/sec in walking on level ground) which might need less hamstring activity to protect the tibia from anterior draw. The other possibility is that increased gastrocnemius activity occurred in our ACL-deficient subjects (due to the increased ankle plantar flexion) instead of increased hamstring activity.

In the EMGs, the obvious speed-related change in the EMG patterns was the tendency for the amplitude of the EMG activity to increase as walking speed increased. This has been reported by other investigators (Brandell IN: Murray *et al*, 1984). As Milner et al (IN Murray, 1984) and Murray et al (1984) demonstrated, the amounts of change in EMG activity with walking speed can be quite variable between individuals.

Lass et al (1991) studied a fast walking speed on the treadmill for ACL-deficient subjects. They used a 5 Km/hr (1.36 m/sec) speed and studied the EMG activities on the patient's knee muscles at different gradients. EMG activity started earlier in the ACL-deficient groups compared with the controls at all the gradients. The duration of the EMG bursts in the muscles was prolonged in all muscles and the RMS of the EMG amplitude of all muscles increased too. The positive role of the gastrocnemius was emphasised by the alteration both in timing and activity of the muscle. They concluded that altered gastrocnemius and thigh muscle activity occurred as an attempt to stabilise the knee joint. When walking on the treadmill, the patients in our study used a FKB and the activity of the quadriceps muscles (the vastus medialis and the rectus femoris) increased non-significantly as seen when they walked on level ground. This might be due to the physical compression of the bracing on the muscle belly. The activity of the gastrocnemius (both peak and RMS) did not change and the activity of the medial hamstring was reduced following bracing while walking on the treadmill. The taping reduced the activity of most muscles around the knee while walking on the treadmill, similar to walking on level ground, although the difference was not significant. However, it significantly reduced the peak and RMS of the medial hamstring muscle. The taping seemed to be an inhibitory factor for muscle activity in all muscles during all tests. This might be due to the physical compression of taping on the belly of the muscle.

In terms of the onset activation time in the gastrocnemius muscle during walking on the treadmill, this muscle was found to be active between 14% and 50% of the gait cycle in the control subjects. However, in the non-braced ACL-deficient subjects it activated at 6% of the gait cycle and remained active until 51% into the gait cycle (most of the stance phase). The same value (6%) for activation was also reported by Lass et al (1991) during walking on the treadmill in their study at a higher speed of walking (5 Km/hr). No significant differences were found between the non-braced ACL-deficient and the control subjects in terms of onset activation time in our study. When the ACL-deficient subjects

used a FKB, the gastrocnemius muscle activated much earlier, started activity immediately after heel strike and remained active up to 51% of the gait cycle. Therefore, the braced ACL-deficient subjects started muscle activity significantly earlier than that of the controls. No significant differences were found between the taped ACL-deficient and the control subjects during walking on the treadmill either in the peak or in onset activation time.

- Running on the Treadmill

As mentioned earlier, the general EMG signals' shape and patterns were similar between walking on level ground and walking on the treadmill in our study. However, the muscle activities during running on the treadmill had a completely different shape and pattern to what is seen during walking tests. It is important to emphasise that different variables including the period of stance and swing phases and the magnitude of the kinematic and EMG findings are directly related to the speed of walking or running on the treadmill (Shiavi *et al*, 1987). The EMG data presented here is for running on the treadmill at a speed of 10 Km/hr.

As Figures 5-20 to 5-22 show, during walking on level ground and walking on the treadmill the peak activity of the gastrocnemius muscle occurred at 40% of the gait cycle, while during running on the treadmill it started at 75% of the gait cycle (in the late swing or deceleration phase) and peaked at around 10% of gait cycle (in the stance phase).

All muscles showed a higher peak in our ACL-deficient subjects during running on the treadmill when compared with that of the control group, although the difference was not significant. When a FKB was used, the quadriceps muscles (the vastus medialis and the rectus femoris) showed a higher level of activity. The peak and RMS of the gastrocnemius were not changed and amazingly, the medial hamstring muscles showed a lower activity following bracing. None of the changes that occurred during running on the treadmill were significant. Nemmeth *et al* (1997) expressed his view that since knee braces influence the afferent input and proprioception from the ACL-deficient knee to the central nervous system in a high loading situation, one might expect changes in muscle firing patterns, amplitude, and timing. In this study, the non-braced ACL-deficient subjects showed a different activity than that of the control subjects while running on the treadmill. They showed changes in all muscles during the forceful running on the treadmill. In other words, only the gastrocnemius muscle had more activity in the ACL-

deficient subjects relative to the normals and the other three muscles showed less activity in the ACL-deficient subjects when compared with the control group. This might be due to the greater knee flexion in running particularly during foot strike in which the ACL-deficient subjects struck the treadmill with a greater knee flexion angle allowing the gastrocnemius muscle to be activated more and earlier. Neither the FKB nor the taping could significantly change the muscle activity during running on the treadmill.

In conclusion, the results showed great alterations in all muscles in the ACL-deficient subjects. Both the FKB and the taping showed various effects on knee muscle activities. During walking on level ground, the non-braced ACL-deficient subjects showed a decrease in quadriceps and an increase in gastrocnemius and hamstring activity. These findings along with the observed knee flexion and the significantly earlier activation of the gastrocnemius muscle indicated good compensation by the ACL-deficient knee subjects. The bracing increased the quadriceps and reduced the hamstring activity, both non-significantly and did not change the level of gastrocnemius activity during walking on level ground, but caused a significant reduction of onset activation time for the gastrocnemius muscle. The increased quadriceps and decreased hamstring activity following bracing, although not significant, seemed to argue against the subjects having an ACL-minus knee. However, preparing a significant earlier onset activation time for the gastrocnemius muscle is beneficial for the ACL-deficient knees. The taping always reduced all muscle activity and reduced the gastrocnemius onset activation time. Overall, the use of a FKB did not show any negative EMG manifestations. The significantly earlier gastrocnemius activity is very helpful for ACL-deficient subjects while walking on level ground. The increased quadriceps activity might be due to the physical compression of the brace or tape on bulky muscle. The taping did not show any positive changes on the EMG's of the studied muscles.

During walking on the treadmill, the activity of both the quadriceps and the hamstring muscles decreased in the ACL-deficient subjects (non-significantly), but the gastrocnemius showed an increased muscle activity. The bracing, again, increased the quadriceps and decreased the hamstring activity (non-significantly), but the peak gastrocnemius activity was not changed. The brace, however, significantly reduced the onset activation time of the gastrocnemius muscle. The increase in the quadriceps and decrease in hamstring activities and the lack of change in the gastrocnemius activity were all non-significant. The significantly earlier activation of the gastrocnemius occurred only

when the ACL-deficient subjects used a FKB, which is a point in favour of bracing. The taping, again, reduced all muscle activity, however, following the taping, the onset activation time of the gastrocnemius did not occur earlier while walking on the treadmill.

With regard to the above findings, bracing was helpful for the ACL-deficient knees during walking on the treadmill by significantly decreasing the onset activation time of the gastrocnemius muscle. The taping, however, did not show any positive effects on the ACL-deficient knees.

During running on the treadmill, the activity of all four muscles increased in the ACL-deficient knees when compared to the control subjects. The bracing, again, increased the quadriceps muscle activity, decreased the hamstring activity and did not change the gastrocnemius activity (all non-significantly and exactly the same as walking on the treadmill). The onset activation time, interestingly, did not change during running on the treadmill following either bracing or taping. It seems that the ACL-deficient subjects could overcome a knee deficiency by increasing all muscle activity and consequently stiffening the knee joint and producing a stable knee (Markolf *et al*, 1978). Since the FKB increased the quadriceps activity (although non-significantly) and reduced the hamstring activity and seemed to unbalance the stiffened joint during such a forceful activity, it might be inferred that the bracing was not appropriate during running on the treadmill. The taping did not change quadriceps activity but decreased hamstring and gastrocnemius activity and did not show any positive effects for such a forceful activity. Because of the possibility that false confidence is felt by the patients following taping of the abnormal knee, the taping might be considered harmful and unsuitable.

We, therefore, can support our hypothesis regarding the positive EMG effects found while wearing only a FKB during low force activities such as walking on level ground and walking on the treadmill. While running on the treadmill, we can not support our hypothesis as the ACL-deficient subjects showed good stability of their injured knee as a consequence of the physiological protection affected by recruiting all muscles, so no brace was needed for this activity. Since using a FKB changed the patterns of muscle activity (although non-significantly) and may impair the physiological protection and consequently unbalance the stable knee, it is not recommended to be used while running on the treadmill. More studies in this area are strongly recommended. The taping did not change the muscle activity in any modes of tests and due to the fact that it may create a

false impression to the patient that their knee is stable while it is impaired, we no longer recommend taping.

Gastrocnemius Activity and Different Test Surfaces

To discover the possible relationship between different surfaces of movement in this study and the peak and onset activation time of the gastrocnemius muscle in ACL-deficient subjects, we studied these variables in both the ACL-deficient and the control subjects (Table 5-57). Firstly, the variables are discussed for the control subjects and then they will be discussed for the ACL-deficient subjects. The control subjects had an earlier onset activation time in the gastrocnemius muscle during walking on the treadmill relative to walking on level ground ($P=0.003$), but the peak activities were not significantly different. This showed that treadmill exercise might lead to an earlier onset activation time in the gastrocnemius muscle. During walking on the treadmill and running on the treadmill, no significant differences were found in the onset activation time between these two tests in the control subjects. However, the control subjects did show a significantly greater peak activity in their gastrocnemius muscle during running on the treadmill. This clearly showed that when an earlier onset activation time was found the speed of walking or running on the treadmill was not an important factor and the type of surface was the only important factor in the control group. The kinematic data has also shown that both walking and running on the treadmill have led the subjects to have a greater plantar flexion ankle angle, which is directly related to the earlier gastrocnemius activity. During walking on level ground and running on the treadmill, it was expected that the normal subjects would show both an increased peak and an earlier onset activation time in the gastrocnemius muscle in both testing modes.

The same comparisons were applied to the non-braced ACL-deficient subjects. They showed no significant difference between walking on level ground and walking on the treadmill in terms of either onset activation time or peak value, while the control subjects had shown a reduced onset activation time. Studying the kinematic data of the ACL-deficient subjects revealed a greater ankle plantar flexion during both walking on level ground and walking on the treadmill. Therefore, one can expect that since the ACL-deficient subjects had an increased ankle plantar flexion angle during either walking on level ground or walking on the treadmill, it is reasonable to explore if there was any difference in their onset activation time of the gastrocnemius muscle between these two levels (because both of them had already shown a reduced onset activation time). During

walking on the treadmill and running on the treadmill, a significant difference was only shown in the peak value similar to that which had occurred in the normal subjects. In other words, running on the treadmill did not reduce the onset activation time. When a comparison was made between walking on level ground and running on the treadmill, the only difference was in the peak value, which was again opposite to that which occurred in the control subjects who showed significant differences in both peak and onset activation time.

In summary, I conclude that any exercise on the treadmill led to a reduced onset activation time in the gastrocnemius muscle and that this was independent of knee injury and occurred both in the ACL-deficient subjects and the normal subjects. This phenomenon might be due to the increased ankle plantar flexion and/or knee flexion angles, which occurred during treadmill exercise. The next important point raised in this study is that the reduced onset activation time of the gastrocnemius muscle was not related to the speed of exercise on the treadmill, as this phenomenon did not occur during running on the treadmill more than while walking on the treadmill. This might be due to the moving surface of the treadmill that requires a different style of gait adaptation even for normal subjects.

6.3. Summary of Discussion

In this study, the studies carried out on ACL-deficient subjects have demonstrated that the temporospatial parameters, range of movement (ROM), kinematics, kinetics and EMG findings in the ACL-deficient subjects were affected by different gait types and by the use of FKB or taping.

Neither the bracing nor the taping significantly changed the gait variables within the ACL-deficient subjects in terms of the temporospatial parameters. Instead, the bracing could significantly reduce the ROM of the knee and restricted knee joint movements during walking on level ground. The braced ACL-deficient subjects walked on level ground with a smaller ROM in the knee joint, but the taped patients walked with a significantly increased ROM in the ankle joint while walking on level ground. The FKB significantly restricted the ROM of the knee joint during either walking on level ground or walking on the treadmill. However, use of the brace or tape did not significantly change the ankle, knee or hip joint ROM during running on the treadmill. Interestingly, in the control subjects, the "support ROM" in the lower limb joints was less for treadmill exercise than when walking on level ground. The non-braced ACL-deficient subjects showed the greatest "support ROM" during running on the treadmill and the next greatest "support ROM" occurred during walking on level ground. The smallest amount of "support ROM" occurred while walking on the treadmill. In the braced ACL-deficient subjects, the highest "support ROM" was produced while running on the treadmill, because the ROM was not affected by the brace. Walking on level ground had less "support ROM" and finally walking on the treadmill had the lowest "support ROM" in the braced ACL-deficient subjects. For the taped ACL-deficient subjects, the most "support ROM" occurred during walking on level ground and then during running on the treadmill and finally during walking on the treadmill.

The reason why walking on the treadmill showed the lowest "support ROM" was due to the significant reduction of hip ROM during this activity with respect to walking on level ground. While running on the treadmill, although the hip ROM remained unchanged (i.e. similar to walking on the treadmill), the ankle ROM significantly increased and thus the "support ROM" increased during the running trial. Therefore, the greatest hip ROM occurred during walking on level ground and the greatest ankle ROM angle occurred during running on the treadmill. It is deduced that walking on the treadmill needs the

lowest "support ROM" and might be a useful exercise for those with a limited ROM such as patients with severe osteoarthritis or amputees with joint prosthesis.

The general effects of a FKB or taping on angulatory kinematics including knee rotation were negligible during running on the treadmill. It seems that during walking on level ground, the knee joint was affected by the brace, mainly in the swing phase. During walking on the treadmill, the ankle joint seemed to be more sensitive than the other joints. The hip joint showed the least kinematic changes following knee bracing or taping in the ACL-deficient subjects while walking on the treadmill. During running on the treadmill, as opposed to the walking trials, all ACL-deficient subjects showed good knee stability and controlled the deficient knee, so that there were no significant differences between the ACL-deficient and the control subjects in most kinematic parameters. Generally, in kinematics, we confirm some part of our hypothesis, that in low force activity by using a FKB, the kinematics of the ACL-deficient knee will be altered to a better and safer position and that a FKB is more advantageous than taping.

For knee rotation, the ACL-deficient subjects showed significantly greater knee rotation only in the treadmill tests. Both the bracing and the taping conditions showed significant effects on controlling knee rotation at this level when compared to the control subjects. No significant differences existed between the ACL-deficient subjects and the control group during walking on level ground. Since the difference was very low and not significant between the ACL-deficient and the control subjects, expecting a brace or tape to reduce the small amount of rotation in the ACL-deficient knees is not appropriate, although the FKB could reduce the total knee rotation in this level. For knee rotation, we confirmed our hypothesis that a FKB was effective in reducing excessive knee rotation in all test modes. We, however, only confirm the positive effect of taping in the swing phase of walking on the treadmill.

For the measurement of A-P tibial translation, the remarkable translation in the ACL-deficient knees was noticeable in all modes of tests, which was significant mostly in the swing phase. The most restrictive effects of bracing were found during walking on the treadmill in both stance and swing phases. The brace was significantly effective during the stance phase of running on the treadmill. It also significantly reduced the total A-P tibial translation during walking on level ground. The taping, however, showed a contradictory effect in all trials and always increased the A-P tibial displacements. In

addressing my hypothesis, I confirm that only the FKB and not the taping effectively reduced the excessive A-P displacement during low force activity including walking tests. In running trials, bracing may not be as effective as it was for walking.

With regard to the effect of the bracing or taping on the kinetic parameters, apart from some small reduction in moments and power, no specific effect of bracing or taping occurred on the knee joint in the braced or taped ACL-deficient subjects, although the bracing reduced both "support moment" and "support power" in the ACL-deficient subjects. The taping did not change the "support moment" but reduced the "support power". The bracing significantly increased the maximum hip extension moment in the ACL-deficient subjects indicating that the ACL-deficient leaned forward during walking on level ground. The quadriceps avoidance gait (QAG) phenomenon did not occur in any of our ACL-deficient subjects. Only four ACL-deficient subjects showed a quadriceps-reduced activity in this study which was not correlated with their Lysholm score. In my hypothesis, I could not confirm that wearing a FKB or taping was effective as the reduction of moment was not significant.

Some adaptations occurred in the ACL-deficient subjects when the speed of the treadmill increased or when the movement surface changed from level ground to the treadmill.

The vertical and medio-lateral directions of force were significantly lower in the ACL-deficient subjects than the control group. However, neither the bracing nor the taping was significantly effective in changing their magnitude in the ACL-deficient subjects. The brace increased the "impact impulse" force and resulted in the patients walking with a pattern similar to the control subjects. As a result, we confirmed that bracing helped the ACL-deficient subjects to choose a lower speed which consequently reduced the loads on their injured knee. Bracing changed the style of walking in the ACL-deficient patients and altered it to a more normal style. Taping was not helpful and we did not confirm its positive effect in reducing force on the injured knee, although it did not show any harmful effects.

The EMG findings were completely different when comparing walking on the level ground and walking and running on the treadmill. The reduced quadriceps muscle activity in the ACL-deficient subjects was not significant in this study but the hamstrings showed more activity during walking on level ground. The most important changes occurred in the gastrocnemius muscle. The EMG findings in this study

strongly confirmed the complementary role of the gastrocnemius muscle. The bracing played an important role and significantly reduced the onset activation time in this muscle, although it did not significantly change the peak muscle activity.

Since the treadmill exercise encouraged the subjects to use their gastrocnemius muscle earlier which is an important factor in stability for the lax knees, we believe that the treadmill is a safe tool for ACL-deficient subjects to use for light to moderate intensity exercise either with or without a FKB. In other words, by using a treadmill, the ACL-deficient patients train the knee in a similar way to that discussed by Sankjaer et al (1991). Sankjaer instructed his ACL-deficient subjects to use their gastrocnemius muscle and increase their knee stability and thus improving their Lysholm score. Using a FKB is recommended for daily activities, as it was helpful during walking tests by decreasing the onset activation time in the ACL-deficient subjects. It is, however, not recommended for running on the treadmill as it may unbalance the physiologically protected and stable-knee that the ACL-deficient patients demonstrated during their forceful activity as a compensatory reaction. Taping did nothing for ACL-deficient knees and, based on our studies, should be abandoned. In general, we confirmed some parts of our hypothesis; that a FKB would be of advantage during walking exercises either on level ground or on the treadmill. However, we did not confirm the part of our hypothesis regarding the positive effects of bracing on ACL-deficient knees during forceful activity such as running on the treadmill as it seem to unbalance the physiologically stable knee by changing the muscle activity pattern around the knee joint. We recommended more detailed studies of running during forceful activity tests of different types.

CHAPTER SEVEN – CONCLUSIONS

Despite the routine use of taping and functional knee braces, it is clear that there is a lack of sufficient objective justification for their extensive use. The ability of functional knee bracing (FKB) to increase the stability of the ACL-deficient knee by changing the biomechanical factors including kinematics, kinetics and electromyographic parameters towards the normal and safe state and especially the ability of the FKB to control tibial translation remains unclear. A number of investigators have strongly recommended that more detailed studies of the kinematic effects of various braces should be undertaken and that this should be studied *in vivo*.

An understanding of the basic mechanical interface between brace and limb will enhance our knowledge of the physiological and kinematic effects of the brace and will have significant implications for future brace designs. Some studies have described the electromyographic changes in ACL-deficient knees in level walking and running and have emphasised that, in an ACL-deficient knee, an increased hamstring and decreased quadriceps activity (the so-called quadriceps avoidance gait pattern) may help the injured athlete to compensate for their knee laxity caused by the ACL damage. However, the muscular activity changes during the use of knee bracing are not clear and further research has been recommended in this area.

In spite of more research focusing on both the EMG effect of taping on the ankle joint and patellar injuries, there are no recent studies to show the effects of taping on biomechanical factors in the knee joint particularly in reducing anterior-posterior translation and excessive rotation of the tibia relative to the femur in ACL-deficient knees. It can be concluded that despite positive subjective results favouring bracing or taping, the objective proof remains ambiguous and further studies are strongly recommended.

A majority of studies on the biomechanical effects of bracing on the ACL-deficient knee have been carried out using level ground activities. Ironically the injured knee subject frequently asks if he/she can use a treadmill as a useful indoor exercise tool. We are not aware of any multidisciplinary study which has investigated kinematic and

EMG aspects of treadmill exercise carried out at different speeds; and the lack of research in this area has become clear through literature searches. The constant speed which can be maintained in treadmill exercise is valuable for this type of research and should provide consistent data using a high frequency gait analysis system. Such an analysis should reveal the effect of treadmill exercise on the mechanics of the knee and the differences in limb reactions to a treadmill activity when compared to a level ground exercise.

The main hypotheses tested in this study were

- 1) that a functional knee bracing and spiral method of taping would result in advantage for ACL-deficient subjects;
- 2) that these advantages could be identified with respect to temporospatial parameters, kinematics (angular and translatory), kinetics (moment and power), force, and EMG parameters;
- 3) that this improvement would be reflected in better functional ambulation and sports activities in the ACL-deficient knees.

The DonJoy FKB and taping used in this study produced some effects to the entire lower extremity instead of just on the knee joint.

Large kinematic, kinetic and EMG differences were found between the ACL-deficient and the control subjects in our studies. While the ACL-deficient subjects did show lower temporospatial parameters during walking on level ground, which may be compensatory reactions for the deficient knees, they also showed a more flexed lower limb joint while walking on level ground and walking or running on the treadmill. FKB or taping appeared to limit the range of movement of the lower limb joints but interestingly this occurred only during low levels of activity (e.g. walking on level ground or walking on the treadmill) while we found no restriction of ROM during high levels of activity such as running on the treadmill.

Reviewing the kinematics during walking on level ground, the braced knee angles after heel strike were very close to those of the control group. However, while walking on the treadmill, the braced knee angles did not return to their normal level

and increased even further resulting in a more flexed position in response to the moving surface on the treadmill. Taping, when compared to bracing did not have a significant effect during walking on level ground in modifying the knee position towards a more normal condition. Taped ACL deficient subjects walked with a flexed knee posture similar to the posture adopted without brace or tape. In fact, they did not trust the taping to allow them to walk in a normal upright posture. Contrary to expectation, while running on the treadmill (a high force activity more likely to produce abnormal kinematics particularly excessive A-P displacement of the tibia relative to the femur) the ACL-deficient subjects in this study showed very good control on their tibial movements in stance phase. However, they all showed a significantly increased A-P displacement in the swing phase. The FKBs significantly controlled the excessive tibial translation mainly in walking on level ground and walking on the treadmill. The ACL-deficient subjects showed a trend towards larger amounts of knee rotation in all trials although this did not reach statistical significance. The patients were also able to properly control tibial rotation in most of the trials.

During the swing phase, the largest tibial rotation identified occurred during walking on the treadmill, with smaller rotations occurring while running on the treadmill and even less when walking on level ground. The most positive effects of taping were seen during the swing phase of gait, which is an open kinematic chain. In stance phases, taping could not restrict the excessive motion of the tibia and even increased it.

An extension moment for the knee existed throughout the stance phase and was reconfirmed by the EMG measurements. The non-braced ACL-deficient subjects were recorded as having a trend towards a reduced knee extensor moment, a lower ankle dorsiflexion moment, lower extensor and flexor hip moments and a lower "support moment" along with lower generation power and absorption power but these measurements did not reach statistical significance. The ACL-deficient subjects used less muscle activity than the control subjects throughout the stance phase. Wearing a brace reduced the knee extensor moment, ankle dorsiflexor moment, and hip flexor moments and power. Taping, however, had no significant effects on the knee joint, but was associated with increased absorption and generation of ankle power and

decreased hip generation power. Bracing reduced "support moments" in the lower limb, but taping did not change them. Both bracing and taping increased "support power" in the ACL-deficient subjects, but they did not return to normal levels.

No quadriceps avoidance gait pattern was found in this study either from the point of view of moments or EMG signals. Taping, sometimes, showed changes similar to bracing but less marked. However taping always resulted in an increase in the A-P tibial displacements in this study, which is an undesirable effect. Bracing or taping reduced the joint sum of moments and power in the injured knee. The general "support power" was absorptive in the ACL-deficient subjects while it was generation in the control subjects. The ACL-deficient subjects in this study started gastrocnemius activity significantly earlier than the control group, which we believe, is a compensatory phenomenon. The FKB was found to activate the gastrocnemius muscles significantly earlier in the ACL-deficient subjects which we believe is an advantage of the brace in the ACL-deficient subjects, although this did not affect the peak activity of this muscle in the patients. The increased ankle plantar flexion angle in the ACL-deficient subjects during treadmill trials was considered to be a compensatory effect as a consequence of the earlier activation of the gastrocnemius muscle.

With regard to all the findings, it can be concluded that the functional knee brace used in this study was shown to have no harmful effects in ACL-deficient knees. It was found to be helpful in some trials particularly for low force activity such as walking trials. It was deduced that the ACL-deficient knees were stabilised following bracing by restriction of knee ROM and by increasing the ankle plantar flexion angle in which the onset activation time of the gastrocnemius muscle was reduced and the hamstring muscle was placed in a better biomechanical position to pull the tibia back. These changes as well as a direct reduction of A-P tibial translation by the FKB provided a more stable and secure knee for the ACL-deficient subjects, during low force walking activities. While running on the treadmill, the ACL-deficient subjects gained a stable knee by recruiting all muscles around the knee and produced a physiologically stable knee, so that no brace or tape was needed. The FKB or tape was not found helpful during high force activities such as running on the treadmill as they might unbalance

the muscle contraction pattern of the physiologically stable knees and thus increase the risk of knee injury. The brace was as effective for walking on the treadmill as for walking on level ground even though there were large kinematic differences between these two different situations. The results of this study are in agreement with those of Beynnon et al (Beynnon *et al*, 1999) and Fleming et al (Fleming *et al*, 2000) with the additional consideration that our findings have been derived from non-invasive *in vivo* dynamic studies with different work loads which in our opinion is more valuable research. Since the ACL-deficient subjects showed good control of knee stability in most high speed trials, more provocative or forceful tests appear to be required to establish the true value of bracing. However, identifying the more stressful or forceful tests suitable for gait laboratories, which can be controlled under constant conditions for all subjects, is very difficult. The treadmill was found to be a very good, safe and useful tool for tests carried out under controlled situations. The ability of the FKBs to control the A-P displacement of the tibia relative to the femur was confirmed in this study. Using taping in ACL-deficient knees was proved to be less effective and its value for the ACL-deficient tibiofemoral joint still needs to be established.

CHAPTER EIGHT

RECOMMENDATIONS FOR FUTURE RESEARCH

Introduction

Despite the availability of advanced and accurate gait analysis systems to study the effect of intervention into specific joints in the body, controversies still remain over some issues mainly due to the complexity of the movement of the knee joint. There are very few studies available, which focus on the taping of the knee joint as a support tool. To the best of our knowledge, there is no study available to date investigating the effects of taping on the tibiofemoral joint *in vivo*. Even functional knee bracing, for which there is an abundance of literature, still needs more research. The kinematic, kinetic and EMG findings in ACL-deficient knees before and after bracing are still controversial areas and require more research (Vailas & Pink 1993; Beynnon *et al*, 1996; Branch *et al*, 1993; Nemmeth *et al*, 1997; DeVita *et al*, 1999; Ramsey *et al*, 2001).

- This document has some key messages for future researchers. There are:
 - Since the CODA *mpx30* motion analysis system is new in their area of research and few research studies are available using this equipment, in order to compare the results of this study with other studies in this area, it seems necessary to repeat the study with other gait analysis systems such as VICON, ELITE, etc. to find out the extent to which the gait analysis systems might affect on the results.
 - Using a unilateral CODA *mpx30* system, EMG and one force platform proved adequate for the purpose of this study. However, to improve the quality and accuracy of the data, it would have been helpful to record the gait bilaterally, using two CODA *mpx30* systems interlinked and two force platforms.
 - Apart from considerations about the equipment and methods used, there are other ways in which research of this kind can be improved. This study involved patients during walking on level ground and walking and running on the treadmill with a zero degree inclination in an indoor sheltered environment. This kind of study could be extended in a variety of ways to cover a wider range of real-life situations and biomechanical stress. Use of jumping and running in a figure of eight or side step cutting manoeuvres are good examples of tests, but they require a good control of

speed and acceleration of the subjects. Testing the subjects during trials on the treadmill with different speed and different inclinations are also recommended.

- Since the current study was the first *in vivo* study on the effects of taping (using a spiral method) on the tibiofemoral joint, more studies using different methods of taping are also encouraged.
 - Either bracing or taping showed good results during some of the stages of tests. I strongly recommend carrying out a test of the combination of these two tools in ACL-deficient knees. This test could be a duplication of Anderson et al's study (1992) but in an *in vivo* situation.
 - This study was undertaken as research work for a PhD degree and therefore was time limited. The results presented in this study are those obtained immediately following application of a FKB or taping. I strongly believe that acclimatisation to bracing or taping is a very important factor that is likely to change the gait pattern of the ACL-deficient knees. Therefore, it is recommended that the study might be repeated after for instance six months regularly using the brace or taping.
 - Virtual markers played a valuable role in this study particularly in studying the tibial translation. This is a relatively new method and more research is needed in this area to identify any pitfalls which may occur when a dynamic test is performed during different activities.
- There are also some questions that remain to be answered by future work dealing with ACL-deficient knee. They are:
- Do different types of braces have different effects in forceful activities?
 - Is a FKB more helpful for a specific group of ACL-deficient patients? e.g. for patients with a lower Lysholm score.
 - Do different types of taping (e.g. Michigan method) have different effects on the tibiofemoral joints?
 - Do orthoses including brace and tape give a false sensation to the users who may have a subjective feeling of stability despite abnormal mechanics on the knee?
 - To what extent does proprioception take part in low or high-force activities?
 - Finally, with regard to all the positive and negative outcomes of using bracing or taping, under which circumstances can a FKB or taping be prescribed for ACL-deficient patients?

REFERENCES

Journals

- Anderson K., Edward M. Wojtys, Peter V. Loubert, & et al. (1992) A biomechanical evaluation of taping and bracing in reducing knee joint translation and rotation. *Am.J.of Sports Medicine* **20 Jul-Aug.**, 416-421.
- Andersson C.A., Odensten M., Good L., & et al (1989) Surgical or non-surgical treatment of acute rupture of the anterior cruciate ligament. *Journal of Bone and Joint Surgery (Am.)* **71-A**, 965-974.
- Andrews JR., McLeod WD., Ward T & et al. The cutting mechanism. IN: McLean Scott G. (1998) A quantitative analysis of knee joint kinematics during the side step cutting manoeuvre. Implications for non-contact anterior cruciate ligament injury. *Bulletin Hospital for Joint Disease* **57**, 30-38.
- Andriacchi T.P. (1990) Dynamics of pathological motion: applied to the anterior cruciate deficient knee. *Journal of Biomechanics* **23 Supplement review**, 99-105.
- Andriacchi T.P., D.E.Hurwitz, C.Bush-Joseph, & et al. (1997) Clinical implications of functional adaptations in patients with ACL-deficient knees. *Sportorthopadie Sporttraumatologie* **13**, 153-160.
- Andriacchi T.P., EJ Alexander, M.I Toney (1998) A point cluster method for In vivo motion analysis: Applied to a study of knee kinematics. *Journal of Biomechanical Engineering* **120 Dec.**, 743-9.
- Andriacchi T.P. & Birac. D. (1993) Functional testing in the anterior cruciate ligament-deficient knee. *Clinical Orthopaedics and Related Research* **288**, 40-47.
- Ann R.E., Kazunori Yasuda, Bruce Beynnon, & et al (1993) An in vitro dynamic evaluation of prophylactic knee braces during lateral impact loading. *Am.J.of Sports Medicine* **21**, 26-35.
- Arms S.W., Pope M.H., Johnson R.J., & et al (1984) The biomechanics of anterior cruciate ligament rehabilitation and reconstruction. *Am.J.of Sports Medicine* **12**, 8-18.
- Attfield S.F., N.P.Gleeson, & P.Pickering (1997) In-vivo assessment of anterior cruciate ligament strain during walking. *Gait & Posture* **6**, 263-280.
- Attfield S.F., N.P.Gleeson, & P.Pickering (1998) Evaluation of dynamic anterior cruciate ligament strain during ambulation. *Gait & Posture* **7**, 154-155.
- Bach BR., Russell F.Warren, William M.Flynn, & et al (1990) Arthrometric evaluation of knees that have a torn anterior cruciate ligament. *The Journal of Bone and Joint Surgery (Am.)* **72**, 1299-1306.

- Bagger J., Jesper Ravn, Peter Lavard, & et al (1992) Effect of functional bracing, quadriceps and hamstrings on anterior tibial translation in anterior cruciate ligament insufficiency: A preliminary study. *Journal of Rehabilitation Research and Development* **29**, 9-12.
- Baker BE, Heanswyk EV, & Bogosian & et al. A biomechanical study of the static stabilizing effect of knee braces on medial stability. IN: Cowley P, Oparte Paul France and Lonnie E. Paulos (1991): The current state of functional knee bracing research, A review of the literature. *Am.J.of Sports Medicine* **19**, 226-33.
- Barrett DS., AG.Cobb, & Bentley. G. (1991) Joint proprioception in normal, osteoarthritic and related knees. *Journal of Bone and Joint Surgery (Br.)* **1**, 53-6.
- Bayley J.C., Scott R.C., Ewald F.C., & et al (1988) Failure of the metal-backed patellar component after total knee replacement. *Journal of Bone and Joint Surgery (Am.)* **70A**, 668-673.
- Beard D., Kyberd P., O'Connor JJ, & et al (1994) Reflex hamstring contraction latency in anterior cruciate ligament deficiency. *Journal of Orthopaedic Research* **12**, 219-228.
- Beard D.J., Soundarapandian R.S., O'Connor J.J., & et al. (1996) Gait and electromyographic analysis of anterior cruciate ligament deficient subjects. *Gait and Posture* **4**.
- Beck C., Drez, D., Young J., & et al. (1986) Instrumented testing of functional knee braces. *Am.J.of Sports Medicine* **14**, 253-256.
- Benedetti M.G., F.Catani, A.Leardini, & et al. (1998) Data management in gait analysis for clinical applications. *Clinical Biomechanics* **13**, 204-215.
- Berchuck M., Andriacchi TP., Bach BR., & et al. (1990) Gait adaptations by patients who have a deficient anterior cruciate ligament. *The Journal of Bone and Joint Surgery (Am.)* **72**, 871-877.
- Berns G.S., Hull M., & Patterson H.A. (1992) Strain in the anteromedial bundle of the anterior cruciate ligament under combination loading. *Journal of Orthopaedic Research* **10**, 167-176.
- Beynon B.D. & Fleming. B.C. (1998) Anterior cruciate ligament strain in-vivo: A review of previous work. *Journal of Biomechanics* **31**, 519-525.
- Beynon B.D., Howe J.G., Pope M.H., & et al Anterior cruciate ligament strain in-vivo. IN: Beynon B D., M.H.Pope, C.M.Wertheimer (1992): The effect of functional knee-braces on strain on the anterior cruciate ligament in vivo. *The Journal of bone and joint surgery (Am.)* **74**, 1298-1312.
- Beynon B.D., Johnson RJ, Fleming BC, & et al. (1995) Anterior cruciate ligament strain behaviour during rehabilitation exercises In-vivo. IN: Beynon, B.D.and B.C.Fleming

- (1998). "Anterior cruciate ligament strain in-vivo: A review of previous work." *Journal of Biomechanics* **31**, 519-525.
- Beynnon B.D., Pope M., Wertheimer C., & et al (1992) The effect of functional knee-braces on strain on the anterior cruciate ligament in vivo. *Journal of Bone and Joint Surgery (Am.)* **74**, 1298-1312.
- Beynnon B.D. & Renstrom P.A. (1991) The effects of bracing and taping in sports. *Annales Chirurgiae et Gynaecologiae* **80**, 230-238.
- Beynnon B.D., Steven H.Ryder, Lars Konradsen, & et al. (1999) The effect of anterior cruciate ligament trauma and bracing on knee proprioception. *Am.J.of Sports Medicine* **27**, 150-155.
- Beynnon BD. & Johnsson RJ. (1996) Anterior cruciate ligament injury rehabilitation in athlete. *Journal of Biomechanics* **31**, 519-525.
- Beynnon B.D., Johnson R.J., Braden.C., & et al (1997) The effect of functional knee bracing on the anterior cruciate ligament in the weight bearing and non-weight bearing knee. *Am.J.of Sports Medicine* **25**, 353-359.
- Beynnon B., Yu J., Huston D., & et al (1996) A saggital plane model of the knee and cruciate ligaments with application of a sensitivity analysis. *Journal of Biomechanical Engineering* **118**, 227-239.
- Biden E.N. & O'Connor JJ. (1990) Experimental methods used to evaluate knee ligament function. In *Knee Ligaments - Structure, Function, Injury and Repair*. (Daniel D.M., Akeson W.H., & O'Connor J.J., eds) Raven Press, New York.
- Birac D., Andriacchi T, & Batch B. (1999) Time related changes following ACL rupture (1991). IN: Roberts C.S, Gregory S.Rash, et al."A deficient anterior cruciate ligament does not lead to quadriceps avoidance gait." *Gait & Posture* **10**, 189-199.
- Bondar LN; Yergler, WG; Berkoff, DL & et al. Non-operative treatment of isolated anterior cruciate ligament injuries with the Lenox Hill braces. IN: Beynnon B D. and P A. Renstrom (1991). The effects of bracing and taping in sports. *Annales Chirurgiae et Gynaecologiae* **80**, 230-238.
- Branch P.T., Hunter R., Reynolds, P. (1988) Controlling anterior tibial displacement under static loads: A comparison of two braces. *Orthopaedics* **11**, 1249-1252.
- Branch P.T. & Hunter R.E. (1990) Functional analysis of anterior cruciate ligament braces, Review. *Clinical Sports Medicine* **9**, 771-797.
- Branch T.P., Indelicato P.A., Riley S., & et al. (1993) Kinematic analysis of anterior cruciate ligament-deficient subjects during side-step cutting with and without a functional knee brace. *Clinical Journal of Sports Medicine* **3**, 86-94.

- Branch T.P., R.Hunter, & Donath M. (1989) Dynamic EMG analysis of anterior cruciate deficient legs with and without bracing during cutting. *Am.J.of Sports Medicine* **17**, 35-41.
- Brandell BR (1975) Electromyographic-cinematographic study of the calf and quadriceps muscles during walking. IN: Murray, M.P.; L.A.Mollinger; G.M.Gardner; & et al. (1984). Kinematic and EMG patterns during slow, free, and fast walking. *Journal of Orthopaedic Research* **2**, 272-280.
- Bressler B. & Frankel J (1953) The forces and moments in the leg during level walking. IN: Andriacchi (1990): Dynamics of pathological motion: Applied to the anterior cruciate deficient knee. *J.of Biomechanics* **23**, 99-105.
- Butler DL, Noyes FR., & Grood ES (1980) Ligamentous restraints to antero-posterior drawer in the human knee. A biomechanical study. *Journal of Bone and Joint Surgery (Am.)* **62**, 259-270..
- Butler PB., Evans GA, Rose GK, & et al (1991) A review of selected knee orthoses. IN: Beynon B.D.and Renstrom PA.The effects of bracing and taping in sports. *Annales Chirurgiae et Gynaecologiae* **80**, 230-231.
- Cabaund HE. Biomechanics of the anterior cruciate ligament. IN: McLean Scott G., Peter T.Myers, Rober J.Neal, & et al. (1998) A quantitative analysis of knee joint kinematics during the side step cutting manoeuvre. Implications for non-contact anterior cruciate ligament injury. *Bulletin Hospital for Joint Disease* **57**, 30-38.
- Cappozzo A., Angelo Capello, Croce U.D., & et al. (1997) Surface-Marker Cluster Design Criteria for 3-D Bone Movement Reconstruction. *IEEE Transactions Rehabilitation Engineering* **44**, 1165-1174.
- Cappozzo A., Catani F., Leardini A., & et al (1996) Position and orientation in space of bones during movement: experimental artefacts. *Clinical Biomechanics* **11**, 90-100.
- Cappozzo A., F.Catani, U.Della Croce, & et al. (1995) Position and orientation in space of bones during movement: anatomical frame definition and determination. *Clinical Biomechanics* **10**, 171-8.
- Carlsoo S. & Nordstrand A. (1968) The coordination of the knee muscles in some voluntary movements and in the gait in cases with and without knee joint injuries. IN: Branch, T.P.R.Hunter et al. (1989)"Dynamic EMG analysis of anterior cruciate deficient legs with and without bracing during cutting." *Am.J.of Sports Medicine* **17**, 35-41.
- Cawley P., France O.P., & Paulos L.E. (1991) The current state of functional knee bracing research, A review of the literature. *Am.J.of Sports Medicine* **19**, 226-33.
- Ciccotti M.G., Kerlan R., Perry J., & et al. (1994) An electromyographical analysis of the knee during functional activities.II- The anterior cruciate ligament-deficient and reconstructed profiles. *Am.J.of Sports Medicine* **22**, 651-658.

- Clarys J. & Cabri (1993) Electromyography and the study of sports movements: a review. *Journal of Sports Sciences* **11**, 379-448.
- Colville M., Lee CL, JV Cullio, & et al. (1986) The Lenox Hill brace. An evaluation of effectiveness in treating knee instability IN: Beynnon B D Renstrom P.A. (1991) The effects of bracing and in sports. *Annales Chirurgiae et Gynaecologiae* **80**, 230-238.
- Cook FF., Tibone JE, Redfern, & et al. (1989) A dynamic analysis of a fuctional brace for anterior cruciate ligament insufficiency. IN: Beynnon, B.D.Steven H.Ryder Lars Konradsen et al (1999) "The effect of anterior cruciate ligament trauma and bracing on knee proprioception." *Am.J.of Sports Medicine* **27**, 150-5.
- Cornwall MW, Thomas G. McPoil (2000) Velocity of the centre of pressure during walking. *Journal of the American Podiatric Medical Association*. July/August 90(7): 334-338.
- Corrigan J.P., Cashman W.F., & Brady M.P. (1992) Proprioception in the cruciate deficient knee. *The Journal of Bone and Joint Surgery (Br.)* **74**, 247-250.
- Coughlin L., Oliver J., & Bretta G. (1999) Knee bracing and anterolateral rotatory instability (1987). IN: Beynnon,B.D.Steven H.Ryder Lars Konradsen et al."The effect of anterior cruciate ligament trauma and bracing on knee proprioception." *Am.J. of Sports Medicine*. **27**, 150-155.
- Czerniecki JM & Lippert F O.J. (1988) A biomechanical evaluation of tibiofemoral rotation in anterior cruciate deficient knees during walking and running. *Am.J.of Sports Medicine Jul-Aug* **16**, 327-331.
- Daniel Dale M., Malcolm L.L., Losse G., & et al (1985) Instrumented measurement of anterior laxity of the knee. *Journal of Bone and Joint Surgery (Am.)* **67A**, 720-725.
- Daniel Dale M, Stone ML, Dobson BE, & et al (1994) Fate of the ACL-injured patients. A prospective outcome study. *Am.J.of Sports Medicine* **22**, 632-644.
- Dean G. (1965) An analysis of the energy expenditure in level and grade walking. IN: Shiavi (1985). R.Electromyographic patterns in adult locomotion: A comprehensive review. *Journal of Rehabilitation Research & Development* **22**, 85-98.
- DeVita P., Lassiter T, Hortobagyi T., & et al (1998) Functional knee brace effects during walking in patients with anterior cruciate ligament reconstruction. *Am.J.of Sports Medicine* **26 Nov.-Dec.**, 778-784.
- DeVita P., Hunter P.B., & Skelly W.A. (1992) Effects of functional knee brace on the biomechanics of running. *Medicine and Sciences in Sports and Exercise* **24**, 797-806.
- DeVita P., Tibor Hortobagyi, & Barrier J. (1998) Gait biomechanics are not normal after anterior cruciate ligament reconstruction and accelerated rehabilitation. *Medicine & Sciences in Sports & Exercise* **30**, 1481-8.

- DeVita P., Tibor Hortobagyi, Jason Barrier, & et al (1997) Gait adaptations before and after anterior cruciate ligament reconstruction surgery. *Medicine and Sciences in Sports and Exercise* 29, 853-859.
- Draganich LF. & Vahey JW. (1989) An in-vitro study of anterior cruciate ligament strain induced by quadriceps and hamstring forces. IN: De Vita, P.P.B.Hunter et al."Effects of functional knee brace on the biomechanics of running (1992)". *Medicine and Sciences in Sports and Exercise* 24, 797-806.
- Drillis R.J. (1961) The influence of aging on the kinematics of gait. IN: Shiavi, R.(1985) Electromyographic patterns in adult locomotion: A comprehensive review. *Journal of Rehabilitation Research & Development* 22, 85-98.
- Dye S. (1996) The future of anterior cruciate ligament restoration. *Clinical Orthopaedics* 325, 130-139.
- Eastlack ME, Axe MJ, & Snyder-Mackler L. Laxity, instability, and functional outcome after ACL injury: copers versus noncopers. *Medicine & Sciences in Sports & Exercise* 31[2], 210-215. 1999.
- Elftman H. (1939) Forces and energy changes in the leg during walking IN: Andriacchi (1990): Dynamics of pathological motion: Applied to the anterior cruciate deficient knee. *J.of Biomechanics* 23, 99-105.
- Ellis D.J., Monsell F.P., Shaw D.L., & et al (1994) Prosthetic repair of chronic ACL-deficiency. Long-term follow up. *Journal of Bone and Joint Surgery (Br.)* 76-B Supp 1, 48.
- Fetto J.E. & Marshal J.L. (1980) The natural history and diagnosis of anterior cruciate ligament insufficiency. *Clinical Orthopaedics and related research* 147, 29-38.
- Fleming B., Renstrom P., Beynnon BD, & et al (2000) The influence of functional knee bracing on the anterior cruciate ligament strain biomechanics in weight bearing and nonweight bearing knees. *Am.J.of Sports Medicine* 28, 815-824.
- Frank R., Noyes., & et al (1992) The anterior cruciate ligament-deficient knee with varus alignment. An analysis of gait adaptations and dynamic joint loadings. *Am.J.of Sports Medicine* 20 Nov., 707-716.
- Frankel V., Brustein A., Brooks D., & et al (1971) Biomechanics of internal derangement of the knee, pathomechanics as determined by analysis of the instant centres of motion. *Journal of Bone and Joint Surgery (Am.)* 53A, 945-62.
- Friden T.D., Zatterstrom R., Lindstrand A., & et al (1990) Disability in anterior cruciate ligament insufficiency. *Acta Orthopaedics Scandinavia* 61, 131-135.

- Furman W., Marshall J.L., & Girgis F.G. (1976) The anterior cruciate ligament. A functional analysis based on postmortem studies. *Journal of Bone and Joint Surgery (Am.)* **58**, 179-185.
- Ganko A, Engerbretsen L, Ozer H (2000) The roliometer: a new arthrometer compared with the KT-1000.
- Gauffin H., Petterson G, Tegner Y, & et al Functional testing in subjects with old rupture of the anterior cruciate ligament. IN: Kramer, JF. Dubowitz, T; Fowler, P; et al. (1997): Functional Knee Braces and Dynamic Performance. A Review. *Clinical Journal of Sports Medicine* **7**, 32-9.
- Gehlsen GM, Stewart LB, Van Nelson C, & et al (1989) Knee kinematics: the effects of running on cambers. *Medical Sciences in Sports and Exercise* **21**, 463-466.
- Gibbs N.: Injuries in professional rugby league. A three year prospective study of the south Sydney professional rugby league football club. IN: McLeran Scott G. P. et al. (1998) A quantitative analysis of knee joint kinematics during the side step cutting manoeuvre. Implications for non-contact anterior cruciate ligament injury. *Bulletin Hospital for Joint Disease* **57**, 30-38.
- Girgis FG., Marshall JL & Monajem A (1975) The cruciate ligaments of the knee joint. Anatomical, functional and experimental analysis. *Clinical Orthopaedics and related research* **106**, 216-31.
- Grieve D. (1968) Gait pattern and the speed of walking IN: Shiavi, R. (1985) Electromyographic patterns in adult locomotion: A comprehensive review. *Journal of Rehabilitation Research & Development* **22**, 85-98.
- Hafzy MS, Grood ES, Noyes FR. (1989) Factors affecting the region of most isometric femoral attachments. II. The anterior cruciate ligament. IN: Fu F.H., Harner C., & Vince KG. (1994) *Knee Surgery*. Chapters 35 edn. Williams & Wilkins, Maryland, USA.
- Hamill J., Barr T., & Kenneth G.H. (1992) Timing of lower extremity joint actions during treadmill running. *Medicine and Sciences in Sports and Exercise* **24**, 807-813.
- Harner C.D., Paulos L.E., Greenwald A.E., Rosenberg T.D., & et al. (1994) Detailed analysis of patients with bilateral anterior cruciate ligament injuries. *Am.J.of Sports Medicine* **22**, 37-43.
- Hawkins RJ; Misamore G.W.; Merritt, T.R (1986) Follow up of the acute non-operated isolated anterior cruciate ligament tear, A randomised study with a long-term follow-up period. IN: Dale, M.D et al. Fate of the ACL-injured patient, A prospective Outcome Study. (1994). *Am.J.of Sports Medicine* **14**, 205-210.
- Hirokawa S., Solomonow M., Yun Lu, & et al (1992) Anterior - posterior and rotational displacement of the tibial elicited by quadriceps contraction. *Am.J.of Sports Medicine* **20**, 299-306.

- Hof AH (2000) On the interpretation of support moment. *Gait and Posture* **12**, 196-9.
- Houston ME & PH Goemans (1982) Leg muscle performance of athletes with and without knee support braces IN: Cowley P, Oparte Paul France and Lonnie E.Paulos. (1991) The current state of functional knee bracing research, A review of the literature. *Am.J.of Sports Medicine* **19**, 226-33.
- Huston LJ, Greenfield MLVH, & Wojtys EM (2000) Anterior cruciate ligament injuries in the female athlete: Potential risk factors. *Clinical Orthopaedics and Related Research* 50-63.
- Ingen S. & Van GJ (1980) Some fundamental aspects of the biomechanics of overground versus treadmill locomotion. IN: Nigg, B.M.; Ruud, W.De Boer; Veronica Fisher (1995) A kinematic comparison of overground and treadmill running. *Medicine and Sciences in Sports and Exercise* **27**, 98-105.
- Inglehart T. Strength and Motor Task Performance as Effected by Carbon Titanium Knee Brace in Normal Healthy Males. IN: Cowley P, Oparte Paul France and Lonnie E.Paulos (1991) The current state of functional knee bracing research, A review of the literature. *Am.J.of Sports Medicine* **19**, 226-33.
- Ishii Y., Terajima K., Terashima S., & et al (1997) Three-dimensional kinematics of the human knee with intracortical pin fixation *Clinical Orthopaedics and related research* **343**, 144-150.
- Jerosch J., Prymka M., & Castro WHM. (1996) Proprioception of the knee joint with a lesion of the medial meniscus. IN: Beynnon, B.D.Steven H.Ryder Lars Konradsen et al. (1999)"The effect of anterior cruciate ligament trauma and bracing on knee proprioception." *Am.J.of Sports Medicine* **27**, 150-155.
- Jerosch J. & M. Prymka (1996) Knee joint proprioception in normal volunteers and patients with anterior cruciate ligament tears, taking special account of the effect of a knee bandage. *Arch Orthop Trauma Surgery* **115**, 162-166.
- Jerosch J. & M. Prymka (1996) Proprioceptive capacity of the knee joint area in patients after rupture of the anterior cruciate ligament.[German]. *Unfallchirurg* **99**, 861-8.
- Jerosh J., Thorwesten L, Hahnebeck H., & et al. (1998) The influence of knee bandages on sport specific capabilities in healthy volunteers and patients with rupture of the anterior cruciate ligament. *SPORTVERLETZ SPORTSCHSDEN* **12**, 15-20.
- Johnson R., Beynnon BD, & Nichols C. The treatment of injuries of the anterior cruciate ligament. IN: Osternig L.R., James, C.R. and Bercades, D.T. (1996) Eccentric knee flexor torque following anterior cruciate ligament surgery. *Medicine & Sciences in Sports & Exercise* **28**, 1229-1234.
- Jonsson H., Karrholm J. & Elmqvist L. (1989) Kinematics of active knee extension after tear of the anterior cruciate ligament. *Am.J.of Sports Medicine* **17**, 796-802.

- Jonsson H. & Karrholm J. (1990) Brace effects on the unstable knee in 21 cases: A Roentgen Stereophotogrammetric Comparison of Three Designs. *Acta Orthopaedica Scandinavica* **61**, 313-318.
- Jonsson H. & Karrholm J. (1994) Three-dimensional knee joint movements during a step-up: evaluation after anterior cruciate ligament rupture. In: Andriacchi, T.P.; EJ Alexander, MK I.; Toney. et al (1998) A point cluster method for In vivo motion analysis: Applied to a study of knee kinematics. *Journal of Biomechanical Engineering* **120 Dec.**, 743-749.
- Johnson DS., Smith RB. (2001) Outcome measurement in the ACL-deficient knee-what's the score?. *The Knee* **8**, 51-57.
- Kadaba MP, Ramakrishnan HK, Gaine JC. & et al. (1993) Gait adaptation patterns in patients with ACL-deficiency. IN: Roberts, C.S.Gregory S.Rash et al. (1999)"A deficient anterior cruciate ligament does not lead to quadriceps avoidance gait." *Gait & Posture* **10**, 189-199.
- Kalund S., Sinkjaer T., Lars, Arent-Nielsen, & et al. (1990) Altered timing of hamstring muscle action in anterior cruciate ligament deficient patients. *Am.J.of Sports Medicine* **18**, 245-248.
- Karrholm J. (1989) Roentgen Stereophotogrammetry. *Acta Orthopaedica Scandinavica* **60**, 491-503.
- Karrholm J., ELMQUIST LG., Selvik G, & et al. (1989) Chronic anterolateral instability of the knee. A roentgen stereophotogrammetric evaluation. IN: Jonsson, Hakan; Johan Karrholm; Elmquist, Lars-gunnar. Kinematics of active knee extension after tear of the anterior cruciate ligament. *Am.J.of Sports Medicine* **17**, 796-802.
- Kennedy J.C. & Grainger R.W. (1967) The posterior cruciate ligaments. *Journal of Trauma* **7**, 367-377.
- Kennedy J.C., Weinberg H.W., & Wilson A.S. (1974) The anatomy and function of the anterior cruciate ligament. *Journal of Bone and Joint Surgery (Am.)* **56**, 223-235.
- Kettelkamp D. & Thompson C. (1975) Development of a knee scoring scale. *Clinical Orthopaedics and related research* **107**, 93-99.
- Kimberly H. & Randall Dick (1998) The relationship between the skill level to anterior cruciate ligament injury. *Clinical Journal of Sports Medicine* **8**, 260-5.
- Kirkendall D.T. & W.E.Garrett (2000) The anterior cruciate ligament enigma, Injury mechanism and prevention. *Clinical Orthopaedics & Related Research* **372**, 64-8.
- Knutzen K.M., Barry T.Bates, & Schot. P. (1987) A biomechanical analysis of two functional knee braces. *Medicine & Sciences in Sports & Exercise* **19**, 303-9.

- Knutzen KM., Bates BT, & J. Hamill (1983) Electrogoniometry of post-surgical knee bracing in running. IN: Cawley P, Oparte Paul France, and Lonnie E. Paulos (1991) The Current state of functional knee bracing research. A review of the literature. *Am.J.of Sports Medicine* **19**, 226-33.
- Knutzen KM, BT Bates & J Hamill (1984) Knee bracing influences on the tibial rotation and torque pattern of surgical limb. IN: Cawley P, Oparte Paul France and Lonnie E. Paulos (1991) IN: The Current state of functional knee bracing research. A review of the literature. *Am.J.of Sports Medicine* **19**, 226-33.
- Lafortune M. (1984) The use of intra-cortical pins to measure the motion of the knee joint during walking. Ph.D. Thesis, IN: Ramsey, D.K. and P.F. Wretenberg. "Biomechanics of the knee: methodological considerations in the in vivo kinematic analysis of the tibiofemoral and patellofemoral joint. Review paper (1999). *Clinical Biomechanics* **14**, 595-611.
- Lafortune M., P.R. Cavanagh, & A. Kalenak (1994) Foot inversion_eversion and knee kinematics during walking. IN: Ramsey, D.K. and P.F. Wretenberg. "Biomechanics of the knee: methodological considerations in the in vivo kinematic analysis of the tibiofemoral and patellofemoral joint. Review paper (1999). *Clinical Biomechanics* **14**, 595-611.
- Lafortune MA., Cavanagh P., Sommer H., & et al (1992) Three-dimensional kinematics of the human knee during walking. *Journal of Biomechanics* **25**, 347-357.
- Lange G.W., Hintermeister R.A., Schlegal T., & et al (1996) Electromyographic and kinematic analysis of Graded Treadmill walking and the implications for knee rehabilitation. *JOSPT (Journal of Orthopaedics and Sports Physical Therapy)* **23**, 294-301.
- Laskin R.S. (1995) The posterior cruciate ligament in total knee replacement. *The Knee* **2**, 139-144.
- Lass P., Kaalund S., Fevre S. & et al. (1991) Muscle co-ordination following rupture of the anterior cruciate ligament. *Acta Orthopaedics Scandinavia* **62**, 9-14.
- Limbird T., Shiavi R., Frazer M., & et al. (1988) EMG profiles of knee joint musculature during walking: changes induced by anterior cruciate ligament deficiency. *Journal of Orthopaedic Research* 630-638.
- Liu S., Lunsford T, Gude S, & et al. (1994) Comparison of Functional Knee Braces for Control of Anterior Tibial Displacement. *Clinical Orthopaedics & Related Research* **303**, 203-210.
- Liu S.H., Aaron Daluiski J., & Kabo M. (1995) The effects of thigh soft-tissue stiffness on the control of anterior tibial displacement by functional knee orthoses. *Journal of Rehabilitation Research and Development* **32**, 135-140.

- Lucchetti L., Aurelio Cappozzo, Angelo Capello, & et al (1998) Skin movement artefact assessment and compensation in the estimation of knee-joint kinematics. *Journal of Biomechanics* **31**, 977-984.
- Lysholm J. & Gillquist J. (1982) Evaluating of knee ligament surgery results with special emphasis on use of a scoring scale. *Am.J.of Sports Medicine* **10**, 150-154.
- MacDonald P.B., Hedden D., Pacin O., & Sutherland K. (1996) Proprioception in anterior cruciate ligament-deficient and reconstructed knees. *Am.J.of Sports Medicine* **24**, 774-778.
- Marans H.J., Jackson R.W., Glossop N.D., & et al (1989) Anterior cruciate ligament insufficiency. A dynamic three-dimensional motion analysis. *Am.J.of Sports Medicine* **17**, 325-332.
- Markolf K.L., Graff-radford A., Amstutz H.C., & et al (1978) In vivo knee stability. A quantitative assessment using an instrumented clinical testing apparatus. *Journal of Bone and Joint Surgery (Am.)* **60-A**, 664-674.
- Markolf K.L., Wascher D.C., & Finerman (1993) Direct in vitro measurement of forces in the cruciate ligaments. Part II: The effect of section of the posterolateral structures. *The Journal of Bone and Joint Surgery (Am)* **75**, 387-394.
- Marshall J.L., Fetto J.E., & Botero P. (1977) Knee ligament injuries. *Clin Orthop* **123**, 115-129.
- McClay I. The evolution of the study of the mechanics of running. Relationship to injury. *J.A.Podiatry Med Association*. 90[3], 133-148. 2000.
- McClay I. & Manal. K. (1999) Three-dimensional kinetics analysis of running: significance of secondary planes of motion. *Medicine & Sciences in Sports & Exercise* **31**, 1629-1637.
- McClay I. (1990) A comparison of tibiofemoral and patellofemoral joint motion in runners with and without patellofemoral pain. Ph.D. Thesis, IN: Ramsey, D.K. and P.F. Wretenberg (1999) Biomechanics of the knee: methodological considerations in the in vivo kinematic analysis of the tibiofemoral and patellofemoral joint. Review paper." *Clinical Biomechanics* **14**, 595-611.
- McLean S.G., Peter T.Myers, Rober J.Neal, & et al (1998) A quantitative analysis of knee joint kinematics during the side step cutting manoeuvre. Implications for non-contact anterior cruciate ligament injury. *Bulletin Hospital for Joint Disease* **57**, 30-38.
- McLoughlin S.J. & Smith R.B. (1992) The Leeds-Keio prosthesis in chronic ACL-deficiency. *Clinical Orthopaedics and Related Research* **283**, 215-222.
- McNair P.J., Stanley S.N., & Strauss G.R. (1996) Knee bracing: Effects on proprioception. *Archive of Physical Medicine and Rehabilitation* **77**, 287-289.

- Millet CW., Drez D., & Renstrom. (1991) Knee braces. IN: Beynnon B.D. and P.A. Renstrom, The effects of bracing and taping in sports. *Annales Chirurgiae et Gynaecologiae* 80, 230-231.
- Millet CW., Drez DJ., & et al. (1988) Principles of bracing for the anterior cruciate ligament-deficient knee. IN: Beynnon, B.D. Steven H. Ryder et al. "The effect of anterior cruciate ligament trauma and bracing on knee proprioception (1999)". *Am.J. of Sports Medicine* 27, 150-155.
- Milner m., Basmajian JV, Quanbury A., & et al (1971) Multifactorial analysis of walking by electromyography and computer. In: Murray, M.P.; L.A. Mollinger; G.M. Gardner; Sepic, S.B. (1984). Kinematic and EMG patterns during slow, free, and fast walking. *Journal of Orthopaedic Research* 2, 272-280.
- Milner m. & Quanbury A. (1970) Facets of control in human walking. IN: Shiavi, R. (1985): Electromyographic patterns in adult locomotion: A comprehensive review. *Journal of Rehabilitation Research & Development* 22, 85-98.
- Monsell F.P., Pegg D.J., Shaw D.L., & et al (1992) Anterior Cruciate Ligament Rupture. *Injury* 23, 213.
- Morehouse CA. & Renstrom (1970) Evaluation of knee abduction and adduction. The effects of selected exercise programmes on knee stability and its relationship to knee injuries in college football. Project report. IN: Beynnon B.D. and P.A. (1991) The effects of bracing and taping in sports. *Annales Chirurgiae et Gynaecologiae* 80, 230-238.
- Mortenson WW, Foreman K. (1991) An in vivo study of functional knee orthoses in the ACL disrupted knee. IN: Cowley P. et al.: The current state of functional knee bracing research, A review of the literature. *Am.J. of Sports Medicine* 19, 226-33.
- Munro C.F., Doris I. Miller, & Andrew J. Fuglevand (1987) Ground reaction forces in running: A re-examination. *Journal of Biomechanics* 20, 147-155.
- Murphy MC (1990) Geometry and the kinematics of the normal human knee. IN: Andriacchi, T.P.; EJ Alexander; Toney, MK.; et al (1998) A point cluster method for In vivo motion analysis: Applied to a study of knee kinematics. *Journal of Biomechanical Engineering* 120 Dec., 743-9.
- Murray M.P., Drought AB, & Kory RC. (1964) Walking patterns of normal men. IN: Rudolph KS, Marty E. Eastlack, Michael J. Axe et al. (1998): Movement patterns after anterior cruciate ligament injury: a comparison of patients who compensate well for the injury and those who require operative stabilisation. *Journal of Electromyography and Kinesiology*. 8, 349-362.
- Murray M.P., L.A. Mollinger, G.M. Gardner, & et al. (1984) Kinematic and EMG patterns during slow, free, and fast walking. *Journal of Orthopaedic Research* 2, 272-280.

- Myers K.S., Brandt K., O'Connor J.J. & et al. Synovitic and osteoarthritic changes in canine articular cartilage after anterior cruciate ligament transaction.. IN: Osternig L.R., James, C.R. and Bercades, D.T. (1996) Eccentric knee flexor torque following anterior cruciate ligament surgery. *Medicine & Sciences in Sports & Exercise* **28**, 1229-1234.
- Nemmeth G., Mario Lamontagne, Kam San Tho, & et al (1997) Electromyographic activity in expert downhill skiers using functional knee braces after anterior cruciate ligament injuries. *Am.J.of Sports Medicine* **25**, 635-641.
- Nigg B.M. & Cole.GK. (1999) Optical methods. IN: Ramsey, D.K. and P.F. Wretenberg. "Biomechanics of the knee: methodological considerations in the in vivo kinematic analysis of the tibiofemoral and patellofemoral joint. Review paper." *Clinical Biomechanics* **14**, 595-611.
- Nigg B.M., Ruud W.D.B., & Veronica Fisher (1995) A kinematic comparison of overground and treadmill running. *Medicine and Sciences in Sports and Exercise* **27**, 98-105.
- Nilsson J., Thorstensson A., Halbertsma J., & et al. Changes in leg movements and muscle activity with speed of locomotion and mode of progression in humans. IN: McClay,I. (2000) The evolution of the study of the mechanics of running. Relationship to injury. *J.A.Podiatry Med Association*. 90[3], 133-148. 1985.
- Nordt W., Paymaun Lotfi, Eric Plokin, & al e. (1999) The in-vivo assessment of tibial motion in the transverse plane in anterior cruciate ligament-reconstructed knees. *Am.J.of Sports Medicine* **27**, 611-6.
- Novacheck T.F. (1995) Walking, Running, and Sprinting: A three-dimensional analysis of kinematics and kinetics. *Instructional Course Lectures* **44**, 497-506.
- Novacheck T.F. (1998) The biomechanics of running. *Gait & Posture* **7**, 77-95.
- Noyes F.R., Bassett RW, Grood E., & et al. (1980) *Arthroscopy in acute traumatic hemarthrosis of the knee* IN: Fu, F.H.; (1994) Ciccotti, Michael G. *Knee Surgery*. Chapters 35 edn. Williams & Wilkins, Maryland, pp 687-695.
- Noyes F.R., Grood E., Suntay WJ, & et al. (1983) The three-dimensional laxity of the anterior cruciate deficient knee as determined by clinical laxity tests. IN: Jonsson, Hakan; Johan Karrholm; Elmqvist, Lars-gunnar (1989 Kinematics of active knee extension after tear of the anterior cruciate ligament). *Am.J.of Sports Medicine* **17**, 796-802.
- Osternig L.R. & Robertson. R.N. (1993) Effects of prophylactic knee bracing on lower extremity joint position and muscle activation during running *Am.J.of Sports Medicine* **21**, 733-7.
- Paulos L., Noyes F.R., & Malek M. (1980) A practical guide to the initial evaluation and treatment of knee ligament injuries. *J Trauma* **20**, 498-506.

- Paulos LE, France EP, & Rosenberg TD & et.al. (1987) The biomechanical of lateral knee bracing part 1: Response of the valgus restraints to impact loading. IN: Cowley P, Oparte Paul France and Lonnie E.Paulos (1991) The current state of functional knee bracing research, A review of the literature. *Am.J.of Sports Medicine* 19, 226-33.
- Perlaud R., Frank C., & Fick G. (1995) The effect of elastic bandages of human knee proprioception in the uninjured population. *Am.J.of Sports Medicine* 23, 251-255.
- Perry J. (1990) Gait analysis in sports medicine. *Instructional Course* 39, 319-324.
- Petrone FA & Rood C. (1992) A comparative study of brace effectiveness in the ACL-deficient knee. *Am.J.Knee Surg.* 5, 117-122.
- Philips L.H. (1998) The effects of seasonal changes in Rugby League on the incidence of injury. *British Journal of Sports Medicine* 32, 144-8.
- Podesta L. & Sherman M.F. (1988) Knee bracing. *Orthopaedic clinics north America* 19, 737-745.
- Rackemann S., Robinson A., & Dandy D.J. (1991) Reconstruction of the anterior cruciate ligament with an intra-articular patellar tendon graft and extra-articular tenodesis. *Journal of Bone and Joint Surgery (Br.)* 73-B, 368-373.
- Rahimi A. & Wallace W.A. (2000a) The Effects of Functional Knee Bracing and Taping in the Tibio-Femoral Joint in Athletes with an ACL-Deficient Knee. A Review of the Literature. *Physical Therapy Reviews* 5, 5-21.
- Rahimi A., Wallace, WA. (2000b): The Effects Of Functional Knee Bracing And Taping On The Tibio-Femoral Joint In Athletes With An ACL-Deficient Knee: The Results of a Pilot Study (Abstract). *Gait & Posture* 12 (1): 70
- Ramsey D.K., Mario Lamontagne, Per Renstrom, & et al. (2001). Assessment of functional knee bracing: an in vivo three-dimensional kinematic analysis of the anterior cruciate deficient knee. *Clinical Biomechanics* 16, 61-70.
- Ramsey D.K. & Wretenberg P.F. (1999) Biomechanics of the knee: methodological considerations in the in vivo kinematic analysis of the tibiofemoral and patellofemoral joint. Review paper. *Clinical Biomechanics* 14, 595-611.
- Reinschmidt C. (1996) Three-dimensional tibioalcanal and tibiofemoral kinematics during human locomotion- measured with external and bone markers. Ph.D. Thesis , IN: Ramsey,D.K.and P.F.Wretenberg (1999). Biomechanics of the knee: methodological considerations in the in vivo kinematic analysis of the tibiofemoral and patellofemoral joint. Review paper. "*Clinical Biomechanics* 4, 595-611.
- Reinschmidt C., AJ Van den Bogert. (1997) Tibiofemoral and tibioalcanal motion during walking: External vs. skeletal markers. *Gait and Posture* 6, 98-109.

- Reinschmidt C., AJ van den Bogert, BM Nigg, & et al. (1997) Effect of skin movement on the analysis of skeletal knee joint motion during running. *Journal of Biomechanics* **30**, 729-32.
- Reinschmidt C., A.J. van den Bogert, Lundberg A, & et al (1995) Tibiofemoral and calcaneus-tibia motion during running: skin vs bone markers. IN: Andriacchi, T.P.; EJ Alexander, MK; Toney.; et al (1998) A point cluster method for In vivo motion analysis: Applied to a study of knee kinematics. *Journal of Biomechanical Engineering* **120 Dec.**, 743-9.
- Rennie D.J., Attfield S.F., & Pickering P. (1998) Calculation of upper limb kinematics using bone embedded co-ordinate frames. *Gait & Posture* **8**, 74-5.
- Renstrom P., SW.Arms, TS Stanwyck & et al. (1987) Strain within the anterior cruciate ligament during hamstring and quadriceps activity. IN: DeVita P. et al. (1992) "Effects of functional knee brace on the biomechanics of running." *Medicine and Sciences in Sports and Exercise* **24**, 797-806.
- Richards James G (1999) The measurement of human motion: A comparison of commercially available systems. *Human Movement Science*. **18**, 589-602.
- Rink P.C., Scott R.A., Lupo R.L., & et al. (1989) Team physician 07. A comparative study of functional bracing in the anterior cruciate deficient knee. *Orthop Rev* **18**, 719-727.
- Roberts C.S., Gregory S.Rash, Joshua T.Honaker, & et al. (1999) A deficient anterior cruciate ligament does not lead to quadriceps avoidance gait. *Gait & Posture* **10**, 189-199.
- Roser LA, Miller SJ & Clawson DK. (1971) Effects of taping and bracing on the unstable knee. *Northwest Med.* **70**, 544-546.
- Rovere G.D., Walton W.Curl, & Browning. D.G. (1989) Bracing and taping in an office sports medicine practice. *Clinical Sports Medicine* **8**, 497-515.
- Rudolph K.S., Marty E.Eastlack, Michael J.Axe, & et al. (1998) '1998' Basmajian Student Award Paper, Movement patterns after anterior cruciate ligament injury: a comparison of patients who compensate well for the injury and those who require operative stabilization. *Journal of Electromyography and Kinesiology*. **8**, 349-62.
- Sakane M., Fox R.J., Woo S.L., & et al (1997) In situ forces in the anterior cruciate ligament and its bundles in response to anterior tibial loads. *Journal of Orthopaedic Research* **15 March**, 285-293.
- Satku K., Kumar V.P., & Ngoi S.S. (1986) Anterior cruciate ligament injuries: to counsel or to operate? *Journal of Bone and Joint Surgery (Br.)* **68**, 458-461.

- Schmidth RA. (1982) Motor control and learning. IN: Nigg, B.M.; Ruud, W. De Boer; Veronica Ficher (1995). A kinematic comparison of averground and treadmill running. *Medicine and Sciences in Sports and Exercise* 27, 98-105.
- Shaw D.L., Monsell F.P., McLoughlin S.J., & et al. (1991) Prosthetic repair of chronic ACL-deficiency. *Journal of Bone and Joint Surgery (Br.)* 73, Supplement 1, 88.
- Shelton WR. Barrett GR, & A. Dukes (1997) Early season anterior cruciate ligaments tears. A treatment dilemma. *Am.J.of Sports Medicine* 25, 656-8.
- Shiavi R., Limbird T., Frazer M., & et al. (1987) Helical motion analysis of the knee. I. Methodology for studying kinematics during locomotion. *Journal of Biomechanics* 20, 459-469.
- Shiavi R. (1985) Electromyographic patterns in adult locomotion: A comprehensive review. *Journal of Rehabilitation Research & Development* 22, 85-98.
- Shiavi R., Thomas Limbird, Mardy Frazer, & et al (1987) Helical motion analysis of the knee- II. Kinematics of uninjured and injured knees during walking and pivoting. *Journal of Biomechanics* 7, 653-665.
- Shiavi R., Bugle H., & Limbird T. (1987) Electromyographic gait assessment, Part I: Adult EMG profiles and walking speed. *Journal of Rehabilitation Research and Development* 24, 13-23.
- Shiavi R., Zhang L.-Q., Limbird T., & Edmondstone M.A. (1992) Pattern analysis of electromyographic linear envelopes exhibited by subjects with uninjured and injured knees during free and fast speed walking. *Journal of Orthopaedic Research* 10, 226-236.
- Shoemaker S.C. & Markolf K.L. (1985) Effects of joint load on the stiffness and laxity of ligament deficient knees. *Journal of Bone and Joint Surgery (Am.)* 67, 136-146.
- Siler W.L., Amy L.Jorgensen, & Norris R.A. (1997) Grasping the handrails during treadmill walking does not alter saggital plane kinematics of walking. *Archives of Physical Medicine and Rehabilitation* 78, 393-398.
- Sinkjaer T. & Arendt-Nielsen (1991) Knee stability and muscle coordination in patients with anterior cruciate ligament injuries. *Journal of Electromyography and Kinesiology.* 1, 209-217.
- Smith R.B., McLoughlin S.J., & Seedhom B.B. (1987) Anterior cruciate ligament replacemnt with the Leeds-Keio prosthesis. *Journal of Bone and Joint Surgery (Br.)* 69, 161.
- Snyder-Mackler L., Delitto A. & Bailey SL. (1995) Strength of the quadriceps femoris muscle and functional recovery after reconstruction of the anterior cruciate ligament. IN: Roberts, C. S., Gregory S. Rash, et al. (1999). "A deficient anterior cruciate ligament does not lead to quadriceps avoidance gait. *Gait & Posture* 10, 189-199.

- Solomonow M., Baratta R, Zhou BH, & et al. (1987) The synergistic action of the anterior cruciate ligament and thigh muscles in maintaining joint stability. *Am.J.of Sports Medicine* **15**, 207.
- Steele J.R. & J.M.M.Brown (1999) Effects of chronic anterior cruciate ligament deficiency on muscle activation pattern during an abrupt deceleration task. *Clinical Biomechanics* **14**, 247-257.
- Styf J.R. (1999) The effects of functional knee bracing on muscle function and performance. *Sports Medicine* **28**, 77-81.
- Sutherland D.H. & Hagy J.L. (1972) Measurement of gait movements from motion picture film. *Journal of Bone and Joint Surgery (Am.)* **54**, 787-797.
- Tegner Y. & Lysholm (1985) Derotation brace and knee function in patients with anterior cruciate ligament tears. *Arthroscopy* **1**, 264-267.
- Tho K.S., Nemeth G., M.Lamontagne & et al (1997) Electromyographic analysis of muscle fatigue in ACL-deficient knees. *Clinical Orthopaedics & Related Research* No. **340**, 142-151.
- Tibone J., Antich FJ, Fanton.G., & et al (1986) Functional analysis of anterior cruciate ligament instability. IN: Branch,T.P.R.Hunter et al. "Dynamic EMG analysis of anterior cruciate deficient legs with and without bracing during cutting (1989)". *Am.J.of Sports Medicine* **17**, 35-41.
- Timoney J.M., Wayne S.Inman, Peter M.Quesada, & et al. (1993) Return of normal gait patterns after anterior cruciate ligament reconstruction. *Am.J.of Sports Medicine* **21**, 887-889.
- Torry M.R., Michael J.Decker, Randall W.Viola, & et al. (2000) Intra-articular knee joint effusion induces quadriceps avoidance gait pattern. *Clinical Biomechanics* **15**, 147-159.
- Toutoungi D., TW LU, A Leardini, & et al. (2000) Cruciate ligament forces in the human knee during rehabilitation exercises. *Clinical Biomechanics* **15**, 176-187.
- Vailas JC. & M. Pink (1993) Biomechanical effects of functional knee bracing. Practical implications. *Sports Medicine* **15**, 210-218.
- Vergis A. & Jan Gillquist (1998) Translation of the Knee During Stair Walking. Comparison of healthy & anterior cruciate ligament-deficient subjects. *Am.J.of Sports Medicine* **26**, 841-6.
- Vergis A., Misha Hindriks, & Gillquist. J. (1997) Sagittal plane translations of the knee in anterior cruciate deficient subjects and controls. *Medicine & Sciences in Sports & Exercise* **29**, 1561-6.

- Viola R.W., J.Richard Steadman, Scott D.Mair; & et al (1999) Anterior cruciate ligament injury incidence within male and female professional alpine skiers. *Am.J.of Sports Medicine* 27, 792-5.
- Wang J.B., Rubin R.M., & Marshall J.L. (1975) A mechanism of isolated anterior cruciate ligament rupture. *Journal of Bone and Joint Surgery (Am.)* 57, 411-413.
- Wascher D.C., Markolf. K.L., Shapiro. M.S. & et al. (1993) Direct in vitro measurement of forces in the cruciate ligaments. Part I: The effect of multiple loading in the intact knee. *The Journal of Bone and Joint Surgery (Am)* 75, 377-386.
- Wexler G., Hurwitz D.E., Bush-Joseph C.A., & et al (1998) Functional gait adaptations in patients with anterior cruciate ligament deficiency over time. *Clinical Orthopaedics and Related Research* No: 348, 166-175.
- Winter D.A. (1983) *Biomechanics and motor control of human movement*. 30 edn., IN: DeVita, Paul; Tibor Hortobagyi; Barrier, Jason. (1998) Gait biomechanics are not normal after anterior cruciate ligament reconstruction and accelerated rehabilitation. *Medicine and Sciences in Sports & Exercise* 30, 1481-8.
- Winter D.A. (1987) Sagittal plane balance and posture in human walking. *IEEE Engineering Medicine and Biology Magazine* 6, 8-11.
- Winter D.A., Arsenault B., & Wooley S. (1980) Step-to-step fluctuations in treadmill gait. Human Locomotion I. IN: Nigg, B.M.; Ruud, W.De Boer; Veronica Ficher (1995) A kinematic comparison of averground and treadmill running. *Medicine and Sciences in Sports and Exercise* 27, 98-105.
- Wojtys EM, Lubert PV, Samson SY, & et al (1990) Use of a knee brace for control of tibial translation. A comparison, in cadavera, of available models. *J.of bone and joint surgery (Am.)* 72, 1323-1329.
- Wojtys EM., Goldstein SA., Redfern M., & et al (1987) A Biomechanical Evaluation of the Lenox Hill Derotation Brace. *Clinical Orthopaedics and Related Research* 220, 179-184.
- Wojtys EM., Sandip U.Kothari, & Huston. L.J. (1996) Anterior Cruciate Ligament Functional Brace Use in Sports. *Am.J.of Sports Medicine* 24, 539-46.
- Zarins B., Nemeth VA. Acute knee injuries in athletes. IN: McLean Scott G. P. et al (1998) A quantitative analysis of knee joint kinematics during the side step cutting manoeuvre. Implications for non-contact anterior cruciate ligament injury. *Bulletin Hospital for Joint Disease* 57, 30-38.
- Zetterlund AE, Serfass RC, & Hunter RE. (1986) The effect of wearing the complete Lenox Hill Derotation Brace on energy expenditure during horizontal treadmill running at 161 meters per minut. IN: (1997) Kramer, John F.; Tracy Dubowitz; Peter Fowler; et

al: "Functional Knee Braces and Dynamic Performance. A Review". *Clinical Journal of Sports Medicine* 7, 32-9.

Books

Allard P., Ian A.F. Stokes, & Blanche J.P. (1995) *Three-Dimensional Analysis of Human Movement*. Human Kinetics.

Arnoczky P. & Warren R.F. (1988) Anatomy of the cruciate ligament. In *The Cruciate Ligaments-Diagnosis and Treatment of Ligamentous Injuries About the Knee*. (Feagin J.A., ed) New York, Edinburgh, London, Melbourne, pp 177-178.

Bartlett R. (1997) *Introduction to Sports Biomechanics*. E & FN SPON, London.

Chao EYS. (1990) Kinetics and kinematics of normal gait. IN: *Gait in Rehabilitation* (Smidt G.L., ed) Churchill Livingstone, New York, pp 45-63.

Charnwood Dynamics (1999) *Charnwood Dynamics, Coda mpx30, User Manual*. Leicestershire.

Cram R. Jeffrey, Glenn S. Kasman, & W.J. Heltz (1998) *Introduction to surface electromyography*. Aspen, Maryland, USA.

Crenshaw AM. (1987) *Campbell's Operative Orthopaedics.*, 7 edn. Mosby Company, Missouri, pp 1153-1211.

Ellis H. (1983) *Clinical Anatomy, Part Four, The Lower Limb.*, 7th edn. Blackwell Scientific Publications, Oxford, pp 275-279.

Ficat RP & Hungerford DS (1977) *Disorders of the patellofemoral joint*. Williams and Wilkins, Baltimore.

Frankel VH & Nordin M (1980) *Basic Biomechanics of the skeletal system*. Lea & Febiger. Philadelphia.

Fu F.H., Harner C., & Vince KG. (1994) *Knee Surgery*. Chapters 3, 25, 35 edn. Williams & Wilkins, Maryland, USA.

Hackney Roger G & Wallace W.A. (1999) *Sports medicine handbook*. BMJ, London, UK.

Hunter L. (1985) Bracing & taping. *Clinical Sports Medicine* 4, 39-54.

Johnson JC & Bach RB (1991) Use of knee braces in athletic injuries. In *Ligament and extensor mechanism injuries in the knee*. (Scott WN, ed) CV Mosby, St. Louis: pp 163-170.

- Kapandji I.A. (1987) *The physiology of the joints*. Churchill Livingstone, Edinburgh.
- Kenneth E.W. & William R Whitehill (1991) *The Comprehensive Manual of Taping and Wrapping Techniques*. The University of Alabama, Cramer Products, Inc., Kansas, USA.
- Kirkwood B.R. (1988) *Essentials of Medical Statistics*. Blackwell, Scientific Publications, pp 197.
- Lockart R.D., Hamilton G.F., & Fyfe F.D. (1974) *Anatomy of the human body*. Faber & Faber Ltd, London.
- Moore K.L. & Agur A.M. (1980) *Clinical Oriented Anatomy*. 2nd edn. Williams & Wilkins, Baltimore.
- Moore K.L. & Agur A.M. (1996) *Essential Clinical Anatomy*. Williams & Wilkins, Baltimore.
- Muller E. (1988) Kinematics of the cruciate ligaments. IN: *The Cruciate Ligaments - Diagnosis and Treatment of Ligaments Injuries About the Knee*. (Feagin J.A., ed) New York, Edinburgh, London, Melbourne, pp 217-234.
- O'Connor J.J. & Zavatsky (1990) Kinematics and Mechanics of the Cruciate Ligaments of the Knee. Vol. 2. IN: *The Biomechanics of Diarthrodial Joints*. (Mow V.C., Ratcliffe A., & Woo S-L-Y., eds) Springer-Verlag, pp 197-242.
- Oxford Dictionary (1990) *Concise Oxford Dictionary*. Oxford University Press, Oxford.
- Perry J. (1992) *Gait Analysis, Normal and pathological function*. Slack Incorporated, New York, USA.
- Sports Medicine Council (1995) *Manual of Athletic Taping*, 3rd. edn. F.A.Davis, Philadelphia.
- Strobel M. & Hans-Werner S. (1990) *Diagnostic Evaluation of the Knee*. Springer-Verlag Berlin, Heidelberg, Germany, pp 110-130.
- Williams PL & Warwick R. (1980) *Gray's Anatomy*, 36th edn. W.B. Saunders, Philadelphia, PA.
- Winter D.A. (1979) *Biomechanics of human movement*. Wiley & Sons Publishers, New York, pp 65-83.
- Winter DA. (1990) *Biomechanics and motor control of human movement*. University of Waterloo Press, Waterloo, Canada, pp 75-102.

Conference Proceedings

American Academy of Orthopaedic Surgeons. Knee Braces Seminar report. 1985. Chicago.

Beard D., DW Murray, J Alfaro, & et al. Control of tibial translation in the cruciate deficient knee. 2000. 17-4-2000.

Brandt K., Myers K.S., Burr D., & et al. Osteoarthritic changes in canine articular cartilage, subchondral bone, and synovium fifty-four months after transection of the anterior cruciate ligament. IN: Osternig L.R., James, C.R. and Bercades, D.T. Eccentric knee flexor torque following anterior cruciate ligament surgery. 28[10], 1229-1234. 1996.

Hassan S.S., Edmondstone M.A., Limbird T, & et al. Reaction force patterns of injured and uninjured knees during walking and pivoting. 1[3], 218-228. 1991.

Kadaba M.P. & Ramakrishnan H.K. Assessment of human motion with VICON. 335-338. 1987. New York, Proceeding of the Biomechanics Symposium, American Society of Mechanical Engineers.

Kiefer G.N., Bell G.D., Luethi S.M., & et al. Gait analysis of patients with chronic anterior cruciate-deficient knees. 31st Annual ORS. 1985. Las Vegas, Nevada.

Lubliner J. & Bash Jeffrey. ACL Bracing Knee Bracing in a Managed Care Environment., Special Report for Orthopaedic Surgeons. 1997.

Mitchelson D. CODA: Evolution and Application. Proceeding of the first World Congress of Biomedics-Image Based Motion Measurement. 26-37. 1990.

Internet Communications

Charnwood Dynamics. Charnwood Dynamics, Coda Technical Information. Internet . 2000. Ref Type: Internet Communication

DeVita P. EMG in ACL-deficient knees. 2000.
Ref Type: Personal Communication (E-mail).

DeVita P. Interpretation of Kinetic data. 2001. 1.
Ref Type: Personal Communication (E-mail).

Kirtly C. Teach-in. "Support Moment". IN: <http://guardian.curtin.edu.au/cga/teach-in/support/>
Access date (20/06/2001)

Patel R.R. & Hurwitz D.E, Andriacchi T.P.& et al. Mechanisms by which patients with anterior cruciate ligament deficiency generate the "Quadriceps Avoidance Gait". (Internet accessed- date 3/8/99). 1999.

Theses

Eberle Roberts J. Anterior cruciate ligament deficient gait under braced & unbraced conditions. 1992, University of Windsor, Canada.

Hunter PB. The effects of running with a functional knee brace on lower extremity joint moments of force in ACL-injured subjects. 1990, Illinois University at Carbondale, USA

Monsell Fergall. Kinematic analysis of the knee following anterior cruciate ligament injury and reconstruction. 1995, University of Salford, UK.

Soundarapandian RS. Gait analysis of the anterior cruciate deficient knee. 1992. University of Oxford, UK.

APPENDICES

Publications & Presentations

Publications

1. Rahimi, A, Wallace, WA (2000a): The Effects Of Functional Knee Bracing And Taping On The Tibio-Femoral Joint In Athletes With An ACL-Deficient Knee: A Review Of The Literature. *Physical Therapy Reviews* 5: 5-21
2. Rahimi, A, Wallace, WA (2000b): The Effects Of Functional Knee Bracing And Taping On The Tibio-Femoral Joint In Athletes With An ACL-Deficient Knee: The Results Of A Pilot Study (Abstract). *Gait & Posture* 12 (1): 70
3. Rahimi, A, Wallace, WA (2001): The Biomechanical Effects Of A Functional Knee Brace (FKB) On The ACL-Deficient Knees During Overground And On Treadmill Trials (Abstract). *Gait & Posture*, 14 (2): 170
4. Rahimi, A, Wallace, WA (2001): Functional Knee Bracing For ACL-Deficient Knees During Gait (Abstract) [To be published in *The Journal of Bone and Joint Surgery*, Br. September 2001].

Presentations

1. The Results of the Pilot Study of This Work Was Presented at 9th Annual Meeting of the European Society for Movement Analysis in Adults and Children (ESMAC), September 28-30, 2000, Lund, Sweden.
2. The Effects of Functional Knee Bracing and Taping on the Tibio-Femoral Joint in Athletes With an ACL-Deficient Knee: The Results of a Pilot Study. Presented at the Iranian Student Seminar (ISS), May 2000, Umist University, Manchester, UK.
3. The Biomechanical Effects Of A Functional Knee Brace (FKB) On The ACL-Deficient Knees During Overground And On Treadmill Trials. Poster Presentation in ESMAC Conference, October 12-14 2001, Rome, Italy.
4. Functional Knee Bracing for ACL-Deficient Knees During Gait. Oral Presentation in the British Orthopaedic Research Society (BORS) Autumn Meeting, September 24-25 2001, Southampton, UK.

Ethical Committee Approval

Was granted by the Queen's Medical Centre (QMC), University Hospital, Ethics Committee.



Queen's Medical Centre
Nottingham

Research and Development Directorate

Our Ref: OR079802

5th October 1998

Mr A Rahimi
Department of Orthopaedic and Accident Surgery
J:IN

Dear Mr Rahimi

Re: The effects of functional knee bracing and taping on the tibio femoral joint in normal athletes and athletes with an ACL deficient knee

The Ethics Committee met on 7th September 1998 and approved the project subject to your providing of some information, or clarification. We are now in receipt of this, and the project is now fully approved, including the protocol, patient information sheet and consent form.

The Ethics Committee require that:

- i) serious adverse reactions/events which occur during the course of the project are reported to the Committee.
- ii) changes in the protocol are submitted as project amendments to the Committee.
- iii) yearly reports and a final report on the project to be submitted. (Forms will be sent to Lead Investigator for completion).

Kind regards

Yours sincerely

Dr I M Holland
Honorary Secretary
Ethics Committee

University Hospital
Nottingham NG7 2UH
Telephone (0115) 9245924
Fax (01 59709196
Direct line (0115) 9705049

Dr Ian Holland, Honorary Secretary, Ethics Committee
Queen's Medical Centre Nottingham, University Hospital NHS Trust

Subject Examination Form

Reference No:

GP:

First name:

Surname:

Sex: Male

Female

Age:

Date of Birth:

Height(m):

Weight(kg):

Dominant hand & Leg:

Address.....

.....

Phone: Day.....Evening.....

Pelvic Width (mm):

Pelvic Depth(mm):

Thigh Length (mm):

Shank Length(mm):

Foot Length:

Knee Width (mm):

Ankle Width(mm):

Circumference of the thigh in:

a) 10 cm above the mid portion of the patella:

b) 15 cm above the mid portion of the patella:

R.O.M:

• *Hip Joint*)

Flexion:

Extension:

Medial rotation:

Lateral rotation:

• *Knee Joint*)

Flexion:

Extension:

Tibial internal rotation:

Tibial external rotation:

• *Ankle Joint*)

Plantar flexion:

Dorsi flexion:

Inversion:

Eversion:

Deformity in: Hip: Knee: Ankle:

• Are you (were you) a professional / amateur athlete? If yes, how often (Involved hours per week).....

• How long are you (were you) doing sports?

Less than 2.5 years [] , Between 2.5 and 7.5 years [] , More than 7.5 years []

Do you do any sport at present?.....

If yes, how vigorous is it? (light [] , Moderate [] , Vigorous []).

Knee: Right [] Left []

Injury) Only ACL injury [] Confirmed by: arthroscopy [] , MRI []

CT Scan [] , Only physical examination []

Combination of ACL injury and other structures:

PCL Ligament [] , Medial Meniscus [] , Lateral Meniscus [] ,

other structures:.....

• In what kind of sport your ACL was ruptured?

Date of injury (Year / Month).....

• How did you injure your knee? (please explain more).....

• Have you had any surgery on your knee? If yes, when and why. What was the outcome?.....

Bracing:

Type of brace.....

• Do you use a brace?

• Is this your first brace?..... Have you changed your brace?.....

• How long are you wearing braces?.....

When do you use your brace? Only during vigorous sports

Only during light sports During all daily activities Never

- Are you confident that you can run on a treadmill for at least 5 minutes with and without your brace at a relatively fast pace? Yes No
- Do you want to do reconstruction surgery?.....
- Have you used taping for your knee injury?.....If yes, who did it and was it useful?

Physical Examination Tests

Anterior drawer test (translation relative to the opposite knee)
 in tibial neutral position:
 in tibial internal rotation:
 in tibial external rotation:

Lachman test: Positive Negative If positive, grade: 1 , 2 , 3

Pivot shift test: 0= Negative , 1= Causing apprehension , 2= Positive
 ,3= Positive with blocking of the tibia

McMurrey test: Negative Positive

Collateral tests: Medial Lateral

Any Medication:.....

Lysholm Score Form

A) Limping (5 points)

None

(5)

Slight or periodical

(3)

Severe and constant

 0)

B) Support (5 points)

None

(5)

Stick or crutch

(2)

Weight-bearing impossible

(0)

C) Locking (15 points)

No locking and no catching sensations

(15)

Catching sensation but no locking

(10)

Locking

Occasionally

(6)

Frequently

(2)

Locked joint on examination

(0)

D) Instability (25 points)

Never giving way

(25)

Rarely during athletics or other sever exertion

(20) Frequently during athletics or other sever-
exertion (or incapable of participation)(15)

Occasionally in daily activities

(10)

Often in daily activities

(5)

Every step

(0)

E) Pain (25 points)

- None (25)
- Inconstant and slight during sever exertion (20)
- Marked during sever exertion (15)
- Marked on or after walking more than 2 Km (10)
- Marked on or after walking less than 2 Km (5)
- Constant (0)

F) Swelling (10 points)

- None (10)
- On sever exertion (6)
- On ordinary exertion (2)
- Constant (0)

G) Stair-climbing (10 points)

- No problems (10)
- Slightly impaired (6)
- One step at a time (2)
- Impossible (0)

H) Squatting (5)

- No problems (5)
- Slightly impaired (4)
- Not beyond 90° (2)
- Impossible (0)

Grades: 91 – 100=Excellent, 84 – 90=Good, 65 – 83=Fair, Lower than 64=Poor

University of Nottingham

Department of Orthopaedic & Accident Surgery

Consent Form

“ The Effects of Functional Bracing and Taping on the ACL-Deficient Knee”

Participant Code.....

Full Name.....

Date of Birth.....

Address.....

.....

.....

Telephone No.

Day:.....

Evening.....

- I am aware that I am not obliged to participate in this study.
- Details of the study have been explained to me and I agree to voluntarily participate in the study.
- I understand the purpose of the study.
- I am aware that the result of this study including photographs or films may be presented at conferences or be published in journals or books.
- I understand I may withdraw the test consent at any time.

Signature of participant.....

Signature of investigator.....

Date.....

University of Nottingham

Department of Orthopaedic & Accident Surgery

Subject Information Sheet

“ The Effects of Functional Bracing and Taping on the ACL-Deficient Knee”

Dear Sir/Madam

This study is being carried out at the Movement Laboratory of the Centre for sports medicine, Department of Orthopaedic & Accident Surgery, QMC, Nottingham.

I would like to invite you to participate in the study.

The purpose of the study is to obtain a better understanding of the changes in the knee joint angles and muscle function following a torn anterior cruciate ligament; and the extent that bracing or taping can close the injured knee towards the normal pattern.

This is a standard and safe treatment and should not cause any pain or discomfort.

You will be required to walk for a short distance at your preferred speed and then run on a treadmill at the speed of 3.5m/ses for 5 minutes.

Before carrying out the test, markers (which will help record your movements) and surface electrodes (which will record your muscle activity) will be attached to your skin and will be filmed during the test.

All the information obtained will be confidential.

The results of the test may be published in scientific journals or be presented at conferences.

The researchers will ensure they will cause you as little inconvenience as possible.

You may withdraw from the study at any time and your future treatment will not be prejudiced.

University of Nottingham

Department of Orthopaedic & Accident Surgery

“ The Effects of Functional Bracing and Taping on the ACL-Deficient Knee”

Letter To GP

Department of Orthopaedic & Accident Surgery
Queens Medical Centre
Nottingham
NG7 2UH
Tel: 0115 924 9924 Ext. 41407

Dear Dr.

I would like to advise you that our research team in the Department of Orthopaedic & Accident Surgery, QMC, Nottingham, are planning to carry out a study of the kinematic, kinetic and electromyographic effects of functional knee bracing and taping on the ACL-deficient knee in athletes.

Mr./Mrs./Miss.....who is your patient, has consented to participate to study. The test is safe, painless, and non-invasive and the normal and ACL-deficient knee subjects will perform a short distance walking and a low speed (3.5 m/sec) running lasting 5 minutes in the Movement laboratory.

Markers and surface electrodes will be attached to the lower extremity of the subjects and they will be filmed while performing the test.

If you have any queries, please do not hesitate to contact me at the above address.

Yours sincerely

Professor W A Wallace

University of Nottingham
Department of Orthopaedic & Accident Surgery

“ The Effects of Functional Bracing and Taping on the ACL-Deficient Knee ”

A Summary of the Project in Lay Language

The anterior cruciate ligament (ACL) is the most important ligament in the knee. It provides constraint to prevent anterior displacement of the tibia relative to the femur and is thought to be especially important for anterior-posterior stability when the knee is flexed. ACL injuries are the most common ligament injuries of the knee.

Following an ACL-injury, the adjacent supporting structure at the knee such as menisci and other ligaments will be exposed to further degeneration. Functional knee bracing (FKB), rehabilitation and surgery are the optional treatment of the ACL-deficient knee. FKB has been used for a long time either to protect post-operatively or to stabilise pre-operatively an ACL-deficient knee. In spite of satisfactory subjective results following knee bracing, the actual biomechanical and laboratory effects of FKB are not clear.

To evaluate the objective effects of FKB, many researchers have used manual clinical tests, arthrometer and electrogoniometer devices to measure the tibial displacement. Because of the problems related operator errors, the results of their studies are not reliable. Many researchers have suggested that the tests should be repeated by using an optoelectronic device.

Taping is the another application for preventing the ligamentous injuries, which is highly recommended by team physician and physiotherapists and is frequently used by athletes in sporting fields. No laboratory effectiveness is known by use of taping in the knee ligament injuries. Some literature has shown that in ACL injuries, an especial taping technique can effectively support the knee and prevent further injuries.

The primary purpose of this research is to determine the usefulness of FKB or taping in controlling the anterior tibial displacement. This research relates to better understanding of the real effects of bracing or taping and will help the ACL-deficient subjects to be able to confidently participate with no concern about further injuries.

In this study 30 ACL-deficient and healthy athletes will be evaluated in the Movement Laboratory of the Department of Orthopaedic & Accident Surgery, QMC, Nottingham. Each participant will provide written informed consent for the participation in the study. Markers and surface electrodes will be attached to landmarks of the body. Then the subjects will be asked to walk normally and to run at 3.5 m/sec on a treadmill for 5 minutes with and without bracing or taping. A CODA *mpx30* gait analyser, a force platform and an EMG device will record the subjects joint angles changes.

This test includes safe, painless and comfort activities and should not cause the participants any discomfort or undue distress.

Glossary

ACL: Anterior Cruciate Ligament. Dense connective tissues in the knee joint that connects the femur and tibia and provides the knee joint a directional and rotational stability.

Anthropometry: Refers to physical measurements of the human body, i.e. age, height, weight and joint width measurement.

CODA: CODA is an opto-electronic scanning gait analysis device used in this study to record the trajectories of the markers attached to the subjects. CODA-3 was the old version that has now been superseded by CODA *mpx30* using an active LED system.

EMG: Electromyography. A technique for recording changes in the electrical potential of a muscle when it is contracted by a motor nerve impulse. Surface EMG, needle EMG and fine wire EMG are three types of the current electromyographic techniques.

FKB: Functional Knee Brace. Those braces designed to assist or provide stability to the knees suffer from an instability syndrome, usually resulting from the absence of one or more ligamentous structures, such as the anterior cruciate ligament.

GRF: Ground Reaction Force. GRF is the force that reacts to the contact of the foot on the ground. It is equal in magnitude and opposite in direction to the push applied by the foot.

Kinematics: Refers to the study of body motion but without consideration to the forces that cause the motion.

Kinetics: Refers to the study of the relationship between body motion and the forces which act on the body.

LED: Light-emitting diode. A system of marker detection in some gait analysis systems such as CODA and Selspot.

MMT: Manual Muscle Testing. A method of measurement of the human muscle power that divides the power into five grades. Grade 5 is the highest grade in which muscles are with "normal" power; and grade 1 is the lowest grade in which the muscles are with "trace" power. Other grades including "good", "fair" and "poor" are the muscle power between grades five and one, respectively. In this category, the paralysed muscles are in the grade of zero.

QAG: Quadriceps Avoidance Gait. A especial pattern of gait in the ACL-deficient knee subjects in which the subjects use a protective mechanism on their affected knee and show a diminished quadriceps muscle contraction during activities.

ROM: Range of Motion. The degrees of the angles of the joints in the body.

Sagittal Plane: The imaginary plane which divides the body into symmetrical right and left halves.

Spatial: Distance.

Temporal: Timing